



STANDARD LEGEND 1995

Date of issue : October 1995

The copyright of this document is vested in Shell International Exploration and Production B.V., The Hague, the Netherlands. All rights reserved.
This document may be reproduced, stored in any retrieval system or transmitted in any form or by any means without the prior written consent of the copyright owner, except for the purpose of commercial exploitation.

SHELL INTERNATIONAL EXPLORATION AND PRODUCTION B.V., THE HAGUE

Further copies can be obtained from SIEP, Document Centre if approved by the custodian of this document.

INTRODUCTION

The Shell Exploration & Production Standard Legend 1995 is the Shell standard for symbols, abbreviations, display formats and terminology applied in hydrocarbon exploration and petroleum engineering. The beginnings of the document can be traced back for some 60 years and consequently its contents reflect both long established and recently introduced practices, as well as international conventions. Some contents of this document are also to be found in the "AAPG Sample Examination Manual" (Swanson, 1981).

The aim of this document is to promote a standard for communication within Shell's worldwide operating organisation, and within industry and academia. The document is also available on a CD-ROM (inserted in the back cover). However, for copyright reasons the CD-ROM does not include the fold-out figures. Appendix 7 contains a short guide on its use. Symbols which are individually numbered can be copied from the CD-ROM into other applications.

This Standard Legend 1995 is a revision of the 1976 edition. Definitions have been largely omitted; for these, the user is referred to the "Glossary of Geology" (Bates & Jackson, 1987) and the "Geological Nomenclature" (Visser, 1980).

The contents of the various chapters are:

- Chapter 1.0 General contains sections on Rules for Abbreviations, Report Presentation, and Standard Documents, such as Mud Log, Electrical Log Displays, Well Completion (Composite) Log, Well Proposal, Well Résumé, Play Maps and Cross-sections.
- Chapter 2.0 Wells and Hydrocarbons comprises sections such as Well Symbols on Maps and Sections, Well Bore Symbols, Hydrocarbon Shows, Hydrocarbon Fields and Surface Hydrocarbon Seeps.
- Chapter 3.0 Topography is based mainly on international conventions.
- Chapter 4.0 Geology contains the key sections Lithology, Rock Description, and Stratigraphy including Sequence Stratigraphy. Two stratigraphical charts, 'Geological Data Tables Cenozoic - Mesozoic and Palaeozoic', are enclosed.
The section Depositional Environments includes abbreviations and colour codes for palaeobathymetry, and a terminology for detailed facies analysis.
The section Palaeogeographical Maps proposes two standards, one for basin scale maps and one for continental/global scale maps.
The section Structural Geology includes a subsection on Trap Description.
- Chapter 5.0 Geochemistry deals with source rocks, their evaluation, maturity and burial.
- Chapter 6.0 Geophysics is a major chapter including Gravity and Magnetics. The section Seismic also encompasses entries on Seismic Interpretation including Seismic Attribute Maps and Seismic Stratigraphy, and Well Shoot and Vertical Seismic Profile.
- The Alphabetical Index and the Alphabetical Listing of Abbreviations are to be found at the end of this document, together with a number of Appendices, including one on the RGB/CMYK values of the various colours to be used.

The 1995 edition is the result of a multidisciplinary effort by a group of geologists, stratigraphers, geophysicists, geochemists, petroleum engineers and operations engineers from SIEP, Research and Operating Companies striving for consensus without dogma.

The Project Steering Group, compiler and contributors hope that this new edition will be as widely used as its 1976 predecessor.

The Shell Standard Legend 1995 is classed as a non-confidential document.

The Hague, September 1995.

The Project Steering Group for the Standard Legend 1995 was:

R. Buchanan	P.A.B. Marke
P.J.D. van Ditzhuijzen	B.M. Reinhardt
J.R. Freake	L.L. Wakefield
D.L. Loftus	G.J. Williams

The main contributors were:

J.W. Burggraaff	H.P. Mohr
T.J. Faulkner	J.C. Mondt
P.S. Featherstone	M.A. Naylor
G.E.A. Foubert	E.J.M. Overboom
E.A. Haan	Y.M. Quillien
Ms B.K. Howe	M.W. Shuster
P.J.F. Jeans	G.S. Steffens
G.W.M. Lijmbach	M. Wannier

The final draft was reviewed by the Steering Group, Exploration/Production staff of Shell Research B.V., and the following OpCos:

Brunei Shell Petroleum Co Sdn Bhd	Shell UK Exploration & Production Ltd
Nederlandse Aardolie Maatschappij B.V.	The Shell Petroleum Development Co of Nigeria Ltd
Petroleum Development Oman LLC	Sabah Shell Petroleum Co Ltd/Sarawak Shell Bhd

Support was also received from Draughting, Desk-Top Publishing, Information Technology and Editing staff:

E.P.J. Clavaux	J.H. Lek
C. van den Ende	E.C.M. Schmidt
Ms J.J. Hillebrandt	J.J. Wachters
R.M. Holsnijders	A.N.R. Wright

Acknowledgements for granting copyrights are due to Professor W.B. Harland (Cambridge), Dr B.U. Haq (Washington), and Nederlandse Aardolie Maatschappij B.V.

Compiler and Editor: W.G. Witt

Sponsor: D.L. Loftus

CONTENTS LIST

1.0 GENERAL

1.1 Rules for Abbreviations

1.2 Report Presentation

1.3 Standard Documents

- 1.3.1 Mud Log
- 1.3.2 Electrical Log Displays
- 1.3.3 Well Completion (Composite) Log
- 1.3.4 Well Proposal
- 1.3.5 Well Résumé
- 1.3.6 Play Maps and Cross-sections

2.0 WELLS AND HYDROCARBONS

2.1 Well Symbols on Maps and Sections

- 2.1.1 Surface Location Symbols
- 2.1.2 Subsurface Location Symbols
 - 2.1.2.1 Technical Status
 - 2.1.2.2 Hydrocarbon Status
 - 2.1.2.3 Production Status
 - 2.1.2.4 Injection Status
 - 2.1.2.5 Completion Status
 - 2.1.2.6 Geological/Structural Information
 - 2.1.2.7 Type of Well
- 2.1.3 Deviated Holes
- 2.1.4 Horizontal Holes
- 2.1.5 Multilateral Holes
- 2.1.6 Multilateral Horizontal Holes

2.2 Well Bore Symbols

- 2.2.1 General Drilling Data
- 2.2.2 Formation Lithological Sampling and Dip Data
- 2.2.3 Casing and Cementations
- 2.2.4 Completion Methods
- 2.2.5 Formation Treatment
- 2.2.6 Production Test Results and Data
- 2.2.7 Lithology
- 2.2.8 Hydrocarbons, Gases and Waters
 - 2.2.8.1 Gas
 - 2.2.8.2 Oil
 - 2.2.8.3 Solid Hydrocarbons
 - 2.2.8.4 Formation Waters
 - 2.2.8.5 Vintage Hydrocarbon Show Symbols

2.3 Hydrocarbon Show Reporting

2.4 Hydrocarbon Fields and Prospects on Maps and Sections, Colour Coding

2.5 Surface Hydrocarbon and Water Seeps (Shows) on Maps

- 2.5.1 Gas
- 2.5.2 Oil
- 2.5.3 Solid Hydrocarbons
- 2.5.4 Surface Water Springs, Seepages

2.5.5 Mud Volcanoes

3.0 TOPOGRAPHY

3.1 Survey Datum

3.2 Survey Reference Points

3.2.1 Horizontal Control Points

3.2.2 Vertical Control Points

3.2.3 Other Position Markers

3.2.4 Survey Control Lines

3.3 Boundaries

3.3.1 Political Boundaries

3.3.2 Concession Boundaries

3.3.3 Area Limits Offshore

3.3.4 Area Limits on Land

3.4 Artificial Features

3.4.1 Linear Features

3.4.2 Point Features

3.4.3 Area Features

3.4.4 Offshore Structures and Markers

3.4.5 Informative Symbols

3.5 Natural Features

3.5.1 Linear Features

3.5.2 Point Features

3.5.3 Area Features

3.5.4 Environmental Maps

3.6 Elevation Contours

3.7 Bathymetric Contours

4.0 GEOLOGY

4.1 Photogeology

4.1.1 Morphological Features

4.1.2 Geological Features

4.2 Lithology

4.2.1 Order of Description

4.2.2 Siliciclastics

4.2.2.1 Framework Composition

4.2.2.2 Siliciclastic Lithotypes

4.2.3 Carbonates

4.2.3.1 Carbonate Classification

4.2.3.2 Carbonate Lithotypes

4.2.4 Mixed Siliciclastics-Carbonates

4.2.5 Evaporites

4.2.6 Organic-rich Rocks

4.2.7 Miscellaneous Sediments

4.2.8 Igneous Rocks

4.2.8.1 Intrusive (Plutonic) Rocks

4.2.8.2 Dykes, Sills

4.2.8.3 Extrusive (Volcanic) Rocks

4.2.8.4 Ophiolites

4.2.9 Metamorphic Rocks

4.2.10 Lithological Colour Symbols

4.3 Rock Description

4.3.1 Texture and Composition

4.3.1.1 Grain Size

4.3.1.2 Sorting

4.3.1.3 Roundness

4.3.1.4 Sphericity

4.3.1.5 Compaction

4.3.1.6 Non-skeletal Particles

4.3.1.7 Non-skeletal Particle Texture and Size

4.3.1.8 Pellets and Coated Grains

4.3.1.9 Skeletal Particles

4.3.1.10 Compositional Siliciclastics Classification

4.3.2 Porosity and Permeability

4.3.2.1 Fabric Selective Porosity

4.3.2.2 Non-fabric Selective Porosity

4.3.2.3 Relative Timing of Porosity Generation

4.3.2.4 Porosity (qualitative by visual estimate)

4.3.2.5 Permeability (qualitative)

4.3.2.6 Archie Classification

4.3.2.7 Archie Porosity Types

4.3.3 Colour Description

4.3.3.1 Colours

4.3.3.2 Modifying Adjectives

4.3.4 Accessory Minerals

4.3.5 Fossils

4.3.5.1 Fossils, General

4.3.5.2 Fossils, Specific

4.3.5.3 Ichnofossils

4.3.5.4 Organogenic Structures

4.3.6 Stratification and Sedimentary Structures

4.3.6.1 Bed Thickness

4.3.6.2 Bedding Appearance

4.3.6.3 Character of Base of Bed

4.3.6.4 Miscellaneous Terms

4.3.6.5 Large Sedimentary Features

4.3.6.6 Cross-bedding

4.3.6.7 Ripplemarks on Bedding Planes

4.3.6.8 Horizontal Lamination

4.3.6.9 Wavy/Irregular/Lenticular Stratification

4.3.6.10 Graded Beds

4.3.6.11 Lineations on Bedding Planes

4.3.6.12 Soft Sediment Deformation

4.3.6.13 Syndepositional Marks and Miscellaneous Structures

4.3.7 Post-depositional Features

4.3.7.1 Miscellaneous Post-depositional Features

4.3.7.2 Diagenetic Structures

4.3.7.3 Nodules/Concretions

4.4 Stratigraphy

4.4.1 Lithostratigraphy

4.4.1.1 Lithostratigraphical Terminology

4.4.1.2 Lithostratigraphical Gaps

4.4.2 Biostratigraphy

4.4.2.1 Zonal Terminology

- 4.4.2.2 Zones/Zonation
- 4.4.2.3 Quantity Symbols for Distribution Charts
- 4.4.3 Chronostratigraphy and Geochronology
- 4.4.4 Sequence Stratigraphy
- 4.4.5 Stratigraphical Boundaries on Maps
 - 4.4.5.1 General
 - 4.4.5.2 Layer Maps
- 4.4.6 Gaps and Unknown Formations
 - 4.4.6.1 Gaps on Columnar Sections and Stratigraphical Tables
 - 4.4.6.2 Gaps on Layer Maps

4.5 Depositional Environments

- 4.5.1 Biostratigraphical Charts
 - 4.5.1.1 Abbreviations
 - 4.5.1.2 Colour Coding
- 4.5.2 Maps and Sections, Colour Coding
- 4.5.3 Facies Terminology
 - 4.5.3.1 Clastic Facies
 - 4.5.3.2 Carbonate Facies

4.6 Palaeogeographical Maps

- 4.6.1 Basin Scale Maps
- 4.6.2 Continental/Global Scale Maps

4.7 Structural Geology

- 4.7.1 Faults, General Aspects
- 4.7.2 Faults on Surface Geological and Horizon Maps
 - 4.7.2.1 Symbols for Fault Types
 - 4.7.2.2 Re-activated Faults
 - 4.7.2.3 Fault Reliability and Heave
 - 4.7.2.4 Horizon Contours
 - 4.7.2.5 Fault-Contour Relationships
- 4.7.3 Folds and Flexures
- 4.7.4 Dip and Strike Symbols on Surface Geological Maps
 - 4.7.4.1 Bedding
 - 4.7.4.2 Miscellaneous Structural Features
- 4.7.5 Structural Cross-sections
- 4.7.6 Trap Descriptions
 - 4.7.6.1 Basic Trap Elements
 - 4.7.6.2 Trap Styles in Different Tectonic Settings
- 4.7.7 Closures on Play, Lead and Prospect Maps
 - 4.7.7.1 Structural Closure
 - 4.7.7.2 Non-structural Closure

5.0 GEOCHEMISTRY

5.1 Source Rocks

- 5.1.1 Source Rock Type
- 5.1.2 Source Rock Evaluation
 - 5.1.2.1 Interpretation of Rock Eval Data
 - 5.1.2.2 Van Krevelen Classification of Kerogen Types

5.2 Source Rock Maturity and Hydrocarbon Generation

- 5.2.1 Maturity Zones
- 5.2.2 Burial Graph
- 5.2.3 Maturity vs. Depth Graph

6.0 GEOPHYSICS

6.1 Seismic

6.1.1 Seismic Acquisition and Location Maps

6.1.2 Seismic Processing and Display

6.1.2.1 Side Label

6.1.2.2 Data along Section

6.1.2.3 Polarity Conventions

6.1.3 Seismic Interpretation

6.1.3.1 Interpreted Seismic Sections

6.1.3.2 Seismic Attribute Maps

6.1.3.3 Seismic Stratigraphy

6.1.3.4 Seismic Contour Maps

6.1.4 Well Shoot and Vertical Seismic Profile

6.2 Gravity

6.3 Magnetics

References

Alphabetical Index

Alphabetical Listing of Abbreviations

Appendices

1. Chronostratigraphical Units, Ordered by Age
2. Chronostratigraphical Units, Alphabetical
3. Chronostratigraphical Units, Abbreviations, Alphabetical
4. Colours, Names and RGB/CMYK Values
5. Definitions of Depth Measurements
6. Thickness Definitions
7. The CD-ROM Version

1.0 GENERAL

1.1 Rules for Abbreviations

Abbreviations are used by the Royal Dutch/Shell Group of Companies on (geological) maps and sections, on well logs, in fieldbooks, etc. In all these cases brevity is essential to record the information in a limited space.

When using abbreviations adherence to the following rules is essential:

1. Initial letters of abbreviations
The same abbreviation is used for a noun and the corresponding adjective. However, nouns begin with a capital letter, adjectives and adverbs with a small letter.
2. Singular and plural
No distinction is made between the abbreviation of the singular and plural of a noun.
3. Full stop (.)
Full stops are not used after abbreviations.
4. Comma (,)
Commas are used to separate groups of abbreviations.
Example: sandstone, grey, hard, coarse grained, ferruginous
→ Sst, gy, hd, crs, fe
5. Semi-colon (;)
Semi-colons are used to separate various types of rocks which are intercalated.
Example: shale, brown, soft with sand layers, fine grained, glauconitic
→ Sh, brn, soft; S Lyr, f, glc
6. Dash (-)
Dashes are used to indicate the range of a characteristic.
Example: fine to medium, grey to dark grey
→ f - m, gy - dk gy
7. Plus (+)
Used as an abbreviation for "and".
Example: shale and sand
→ Sh + S
8. Plus - minus (±)
Used as the abbreviation for "more or less" or "approximate".
Example: shale with approximately 25 % sand
→ Sh ± 25 % S
9. Underlining
Used to add emphasis to an abbreviation.
Examples: very sandy → s
well bedded → bd
very well sorted → srt
10. Brackets
Used to indicate diminutive adjectives or adverbs and indefinite colours.
Examples: slightly sandy → (s)
bluish grey → (bl) gy
poorly sorted → (srt)

1.2 Report Presentation

Preparation of Reports

General Remarks

A certain degree of uniformity in the presentation of reports is desirable. In order to facilitate filing, the recommended format should be A4 (210 x 297 mm = 8.25 x 11.75 inches; size used in USA and Canada 8 x 10.5 inches). For the cover (and the title page) of the report, adhere to the local company rules with respect to the use of colours, logo, copyright and confidentiality clauses, etc.

The following suggestions are offered regarding the layout:

Text

A report should have a title page and a contents page, following the general lines of specimens as shown on the Figures in this chapter.

A 'summary' or 'abstract' should be given at the beginning of the report. Along with this, also give the 'keywords' as a quick reference to the report and its various subjects.

The pages of the report should be numbered with arabic numerals, while the contents page(s) can be numbered with roman numerals. Pages with odd numbers should appear as right-hand side pages.

In the case of appendices, each appendix should be given its own separate page-numbering. In larger reports, each new chapter or appendix should preferably start on a right-hand page. Each page in the report should carry the report number and the classification 'Confidential'. On the appendix pages, the appendix number should also be present.

The introduction should be the first chapter of the report, stating area, material, data and methods used.

A 'key map' showing the situation of the area covered by the report can be given, e.g. on the inside front cover opposite the title page.



Confidential
EP

Title

Subtitle

Originated by :

Reviewed by :

Approved by :

Custodian :

Date of issue :

Revision :

Date of issue of
revised edition :

Distribution :

The copyright of this document is vested in Shell International Exploration and Production B.V., The Hague, the Netherlands. All rights reserved.
This document may be reproduced, stored in any retrieval system or transmitted in any form or by any means without the prior written consent of the copyright owner, except for the purpose of commercial exploitation.

SHELL INTERNATIONAL EXPLORATION AND PRODUCTION B.V., THE HAGUE

Further copies can be obtained from SIEP, Document Centre if approved by the custodian of this document.

Contents

	Page
Summary	1
1. Introduction	2
2. Methodology and definitions	3
2.1 Sequence stratigraphy	3
2.2 Depositional environments	3
2.3 Abundance-1 log analysis	4
2.4 Seismostratigraphy	5
2.5 Palynological biosignals	7
3. Abundance-1 sequence stratigraphy	12
3.1 Sequence TB ?1.5 or older	12
3.2 Sequence TB 2.1	13
3.3 Sequence TB 2.2	15
3.4 Sequence TB 2.3	16
3.5 Sequence TB 2.4	18
3.6 Sequence TB 2.5	19
3.7 Sequence TB 2.6	20
3.8 Sequence TB 3.1	21
3.9 Sequence TB 3.2	22
3.10 Sequence TB 3.3	22
4. Conclusions	24
5. References	26
List of Figures	
1. Petrophysical display Abundance-1	H78543/1
2. Time/rock synopsis Abundance Basin	H78543/2
List of Tables	
1. Chronostratigraphical summary Abundance-1	H78543/3
2. Nannofloral zones, Abundance-1	H78543/4
3. Palynofloral zones, Abundance-1	H78543/5
List of Enclosures	
1. Palynostratigraphical summary chart Abundance-1	H78543/6
2. Biostratigraphical summary chart Abundance-1	H78543/7
3. Stratigraphical summary Abundance-1	H78543/8
4. Seismostratigraphy, seismic line KC 92-010 (SP 500-1700)	H78543/9
5. Seismic facies, seismic line KC 92-010 (SP 500-1700)	H78543/10

Maps and Report Enclosures/Figures

Enclosures (drawings, plots) should carry a title block in the bottom right-hand corner. They should be marked with a drawing and/or serial number, and with the date and number of the report.

The enclosures should be numbered consecutively; numbers like '1a', '1b' should preferably be avoided.

The title block should be of a size commensurate with the size of the enclosure. For A4/A3 size enclosures, a 2.5 x 5 cm block is appropriate; for larger sizes, the standard is 5 x 10 cm. Subdivision and contents follow local usage, but it is strongly to be preferred that authors identify themselves by name (or initials), thus reversing the recent trend towards departmental anonymity.

SHELL INTERNATIONAL EXPLORATION & PRODUCTION B.V.		
THE HAGUE	NEW BUSINESS DEVELOPMENT	
ARGENTINA - NEUQUEN BASIN THICKNESS OF MARGINAL LOWER JURASSIC Scale 1 : 2 000 000		
Author: A. Miller	Encl.: 5	Date: November 1995
Report No.: EP 95-1620		Draw. No.: H76247/5

Example of title block

For figures, the standard frame for A4/A3 size figures is recommended.

S. I. E. P. - THE HAGUE DEPT: EPX/13 DATE: December 1995 DRAW. No.: H76308/10	ECUADOR - ORIENTE BASIN JURASSIC PLAY MAP	FIGURE No. 3 Report EP 96-0300
---	--	--

Example of the bottom of an A4 figure layout

On maps, geographical and grid co-ordinates should always be shown. In addition the projection system used, all defining parameters and datum should be indicated (see section 3.1). A reference length should also be drawn on the map to allow for shrinkage (e.g. a bar scale).

If true North is not shown on a map (by absence of co-ordinates, geographical grid, etc.), it is assumed that this direction is parallel to the vertical map frame; in all other cases, true North must be indicated by an arrow.

On compilation maps, reference should be given to the maps or databases (topographical, geophysical, etc.) used, e.g.:

Topography acc. to map, (author), rep. No.:, year

Photogeology acc. to map, (author), rep. No.:, year

Seismic locations(file No.),(date)

Where appropriate, the enclosure should also carry a key map showing the area covered by the report and the enclosure.

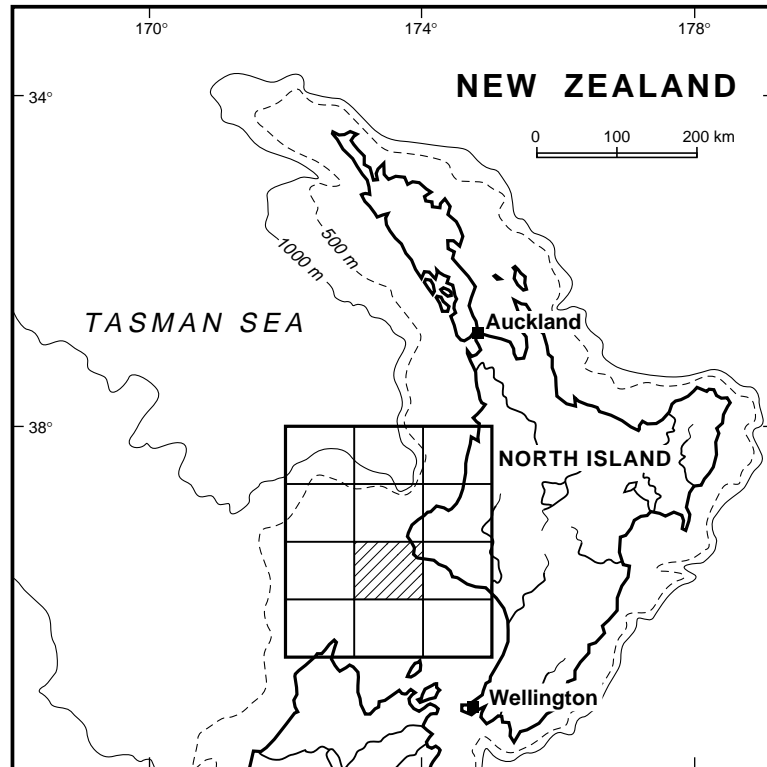

Example of key map

The following rules are recommended for the folding of maps and enclosures to reports:

All enclosures should be folded in the standard A4 size.

If enclosures are to be inserted in plastic sleeves, the folding should be slightly narrower, to allow for easy removal and re-insertion.

When folding, ensure that the title will appear unfolded on the outside.

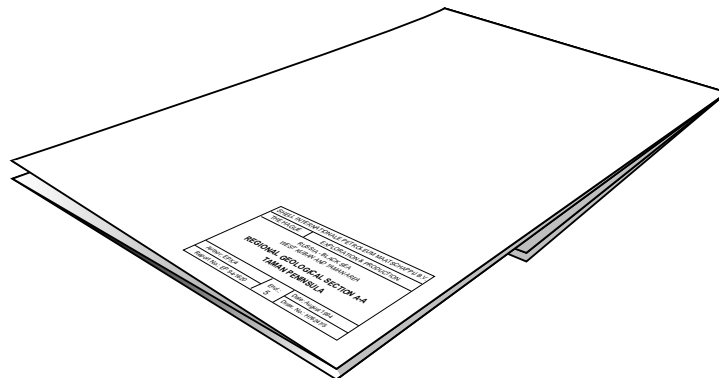

The margin, i.e. the area between the border (frame) of the map and the trim-edge, should not be less than 10 mm (0.4"). Where a map or figure is to be bound with the report, a margin of at least 20 mm (0.8") should be left along the binding edge.

1.3 Standard Documents

1.3.1 Mud Log

Recommended contents, plotted and annotated against a depth scale (generally 1:500), for this document are:

- Dates
- Rate of penetration (avoid back-up scale or frequent changes in scale)
- Lithology of cuttings % (percentage log)
- Lithological description (in abbreviations)
- Interpreted lithological column
- Visual porosity
- Calcimetry (optional)
- Total gas readings and gas chromatography
- Presence of oil shows and oil show description
- Mud data
- Bit data
- Casing shoes with leak-off test
- Drilling parameters
- Basic coring information
- Remarks on losses, gains, gas, oil in mud and H₂S indications

Additional contents, which are generally shown on other documents, are possibly:

- Deviation survey data
- Logging information

Header information should include:

- | | |
|--|---|
| - Well name | - Depth datum |
| - Co-ordinates (indicate provisional or final) | - Total depth (driller) below datum |
| - Spud date | - Total depth (wireline) below datum |
| - Completion/abandonment date | - True vertical depth below sea-level (TVDSS)** |
| - Ground level elevation (GL)* | - Operator |
| - Rotary table/kelly bushing elevation (ELEV)* | - License |
| - Water depth | - Country |

* Definitions see Appendix 5

** Definitions see Appendices 5 and 6

The example given (Fig. 1, only available in the hardcopy version) is the top-hole part of a mud log, which therefore does not show all the above-mentioned items.

1.3.2 Electrical Log Displays

Electrical logs are acquired in separate runs over successive sections of the well-bore. The data are stored both on film and digitally.

The single-run data displays and header information should observe the standards as adhered to on a film layout (set by OPCOs in their procedures manuals), i.e.

- 1) scale orientation and scale type as used on log prints;
- 2) a three or more track display with the depth/lithology column between first and second track.

The display of multiple-run data should be based on the usage of electronically spliced logs which obey the following criteria:

- 1) they should have 'blank' values (nulls) between logged intervals;
- 2) the logs should be marked as 'joined' logs by four letter (LIS-compatible) names ending in 'J'.

The logs for single-run data displays (as used in reservoir evaluation displays) are fed to the plotter and then automatically resampled to fit the plotting steps of the plotter; more detail becomes visible with larger plot length.

Displays of multiple-run data (as used in geological displays) are usually made on 1:1000 or 1:2500 scale, which is about a tenfold reduction compared with the detailed reservoir evaluation scale of 1:200. The electronically accessed log data can thus be resampled from the usual ('standard') 2 samples per foot to 2 samples per 10 feet to obtain quality plots and at the same time reduce the joint log database by a factor ten. It is recommended that the names in this dataset be characterised by an 'R' instead of a 'J' at the end of the four letter name (e.g. GAMR, RESR, CALR, DENR, SONR, NPHR, etc.). The physical parameters logged are expressed in abbreviated form as:

GAM	Gamma Ray	DEN	Density
RES	Resistivity (deep)	SON	Sonic travel time
CAL	Caliper	NPH	Neutron porosity

Contractor's abbreviations/codes of commonly used logging services are:

BHC	Borehole Compensated Sonic Log	IL	Induction Logging
BHTV	Borehole Televierer	LDL	Litho Density Log
CAL	Caliper	LL	Laterolog
CBL	Cement Bond Log	MLL	Micro Laterolog
CDL	Compensated Densilog	MSCT	Mechanical Sidewall Coring Tool
CNL	Compensated Neutron Log	MSFL	Microspherically Focused Resistivity Log
CST	Continuous Sample Taker	NGS	Natural Gamma Ray Spectrometry Log
DLL	Dual Laterolog	PL	Production Log/Flow Profiles
FDC	Formation Density Log	PTS	Pressure Temperature Sonde
FIT	Formation Interval Tester	RFS	Repeat Formation Sampler
FMI	Formation MicroImager	RFT	Repeat Formation Tester
FMS	Formation MicroScanner Log	SHDT	Stratigraphic High-Resolution Dipmeter Log
GHMT	Geological High-Resolution Magnetic Tool	SP	Spontaneous Potential
GR	Gamma Ray Log	TDT	Thermal (Neutron) Decay Time Log
GST	Gamma Ray Spectroscopy Log	TL	Temperature Log
HDT	High Resolution Dipmeter Log		

1.3.3 Well Completion (Composite) Log

Recommended contents for this document (scale 1:1000 or 1:500) are as follows:

- Heading: well name, operating company, country, co-ordinates, elevations (ground level (GL) and derrick floor (ELEV)), water depth, drilling dates, total depths (driller and wireline), true vertical depth below sea-level (TVDSS), well status, logging details (including mud data, bottom hole temperatures (BHT) and time since circulation stopped) for all runs and a location map are essential.

Acreage name/number, Shell share, the legend for the symbols used, the key for oil shows, an interpreted seismic section through the well location and a narrative describing the objectives of the well are optional constituents of the heading.

- A suite of logs - e.g. Gamma ray, caliper, SP, resistivity, borehole compensated sonic - are essential. Where appropriate, formation density and neutron porosity logs displayed as an overlay plot can provide valuable additional data. The caliper and the Gamma ray, the latter optionally displayed as an overlay plot with the sonic log, are shown to the left of the lithological column, the remainder of the logs to the right. If an SP log is used, it is plotted to the left of the lithological column. Interpreted dipmeter data may also be shown.
- Lithological column
- Lithological description
- Lithostratigraphical subdivision. See remarks below.
- Biostratigraphical subdivision/zonation. See remarks below.
- Chronostratigraphical subdivision. See remarks below.
- Hydrocarbon indications: oil shows and total gas readings
- Casing data
- Position (number and recovery) of cores, side wall samples (CST) and mechanical side wall cores (MSCT)
- Deviation data
- AHD (along hole depth) and TVD (true vertical depth): essential in deviated holes
- Two-way travel time and stratigraphical position of key seismic reflections
- Lost circulation and influxes, kicks (interval and amounts)
- Formation pressure readings and drill stem/production tested intervals
The results are summarized at the end of the document.
- Fluid level data
(OWC, ODT, WUT etc.)
- Summary of the petrophysical evaluation
At the end of the document.

Optional items are:

- Key (micro)fossil elements
- Depositional environment interpretation. See remarks below.
- Sequence stratigraphical interpretation. See remarks below.
- Plug-back data

Remarks:

- Lithostratigraphical subdivision

In areas where formal abbreviation codes for lithostratigraphical units have been established (and published), these can be used next to the full name of the unit.

In areas where no formal lithostratigraphical subdivision has been established, an informal lithostratigraphical subdivision should be developed and used.

- Biostratigraphical subdivision/zonation & Chronostratigraphical subdivision

Here a graphical solution is preferred, which differentiates between a chronostratigraphical subdivision based on biostratigraphical data derived from the well under consideration and a chronostratigraphical subdivision based on regional geological correlations and considerations. It is recommended to express the former by the lowest hierarchical unit possible (e.g. NN7 = Upper Serravalian) and the latter by higher ones (Middle Miocene).

- Depositional environment & Sequence stratigraphical interpretation

The depositional environment interpretation is best shown on a smaller-scale (e.g. 1:2500) stratigraphical summary sheet, which, since it displays the essential palaeoenvironmental parameters, is a better document for recording the sequence stratigraphical interpretation, rather than using the well completion log.

The example given (Fig. 2, only available in the hardcopy version) is only a part of a composite log, which therefore does not show all the above-mentioned items.

1.3.4 Well Proposal

Recommended contents for this document are:

- **Well Information Summary**

- Location data and planned TD
- Well objectives and prognosis
- Estimated probability of success (POS) and mean success volume (MSV)

1. Introduction

- Purpose/objective

2. Geological Setting

- Regional geology
- Reservoir and seal development
- Hydrocarbon habitat
 - . Source rock development/distribution/nature (not for development well)
 - . Timing of maturity/expulsion/trap formation (not for development well)

3. Geophysical Interpretation

- Database
- Seismic interpretation: identification of reflections; main interpretation uncertainties
- Depth conversion
- Uncertainties in depth prognosis
- Amplitude Evaluation, DHIs

4. Prospect Appraisal

- Structure
- Reservoir/seal
- Charge (not for development well)
- Risks
- Volumetrics (POS and MSV)
- Economics

5. Prospect Drilling and Operations Information

- Objectives
- Surface and target co-ordinates, target tolerance, TD
- Depth prognosis and uncertainties
- Evaluation requirements, incl. logging, testing, sampling, etc.
- Potential drilling hazards
 - . shallow gas
 - . hydrates
 - . faults
 - . hole problems/unstable formations
 - . H₂S
 - . over/underpressures

6. Costs

7. References

Recommended figures/enclosures for this document are:

- Prospect summary sheet
- Play map (not for development well)
- Regional cross-section(s) and related seismic section(s)
- Seismic stratigraphical interpretation
- Contour maps of key horizons (in time and depth)
- Methods of time-depth conversion
- Large, true-scale structural cross-section of the structure through the proposed well location showing all relevant data, e.g.
 - . interpreted seismic reflections
 - . interpreted faults (with cones of uncertainty)
 - . predicted hydrocarbon occurrences
 - . well track (with target tolerances, deviation data, etc.)
 - . casing points
 - . potential drilling hazards (shallow gas, predicted top overpressures, etc.).
- Volumetric calculations: input data and results

1.3.5 Well Résumé

Recommended contents for this document are:

- **Basic Well Data**
- **Summary**
- 1. Introduction**
- 2. Objectives, Drilling Plan and Results**
- 3. Operations**
 - Drilling
 - Logging and coring
 - Testing
- 4. Markers/Stratigraphy**
- 5. Well Evaluation**
 - Chronostratigraphy
 - Lithostratigraphy and depositional environment
 - Petrophysical evaluation
 - Test evaluation
 - Reservoirs and seals
 - Hydrocarbons/source rocks
- 6. Seismic and Structural Evaluation**
 - Well-seismic match
 - Structural evaluation
 - Dipmeter evaluation
- 7. Reserves**
- 8. Implications of Well Results**
 - Prognosis and results
 - Hydrocarbons
 - Geology
- 9. Costs**
 - Proposed/actual
- 10. References**

Recommended figures/enclosures for this document are:

- Reconciled seismic section
- Well summary sheet
- Well completion (composite) log
- Mud log
- Well progress chart
- Well status diagram

1.3.6 Play Maps and Cross-sections

A 'play' is understood to comprise a group of genetically related hydrocarbon prospects or accumulations that originate from a contiguous body of source rock, and occupy a specific rock volume.

Play maps seek to demonstrate the areal relationship between the source rock and target reservoir and seal pair(s) hosting the hydrocarbon accumulations, using a structural base map.

Play cross-sections seek to illustrate the structural and stratigraphical relationships between the source rock and target reservoir and seal pair(s). To this end it is essential that cross-sections be drawn to scale, with as small a vertical exaggeration as reasonably possible.

Critical elements in play maps and cross-sections are the documentation of hydrocarbon shows and fluid recoveries from wells, the discrimination of relevant wells and whether these wells represent valid structural/stratigraphical tests. These should be depicted as follows:

Well Symbols for Play Maps (or any horizon map)

Only those wells pertaining to the interval mapped should be depicted as indicated in 2.1.2.1 - 2.1.2.3.

For wells which failed to reach the mapped interval, or for wells in which the mapped interval was missing, refer to Section 2.1.2.6.

For those wells interpreted to be invalid structural tests of the interval mapped, the qualifier IV should be used (see Section 2.1.2.6).

Hydrocarbon Fields and Prospects on Maps and Sections, Colour Coding - see 2.4

Closures on Play, Lead and Prospect Maps - see 4.7.7

Shows and Fluid Recoveries

Shows, interpreted hydrocarbons, and fluid recoveries on test can be indicated by use of the appropriate map or section symbol (ref. Sections 2.1.2.2, 2.2.6 & 2.2.8), but for a more visible representation on reservoir, show, or play maps, the following scheme may be used (adapted after Shell Canada):

Hydrocarbons

Gas (green)

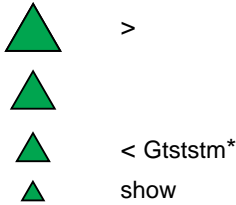

Condensate (orange)

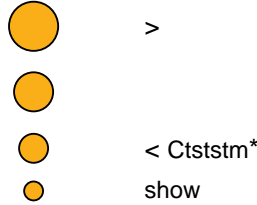

Oil (red)

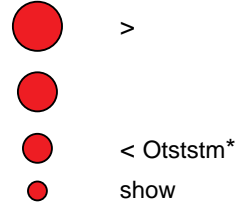

* Gas/Condensate/Oil to surface too small to measure

Water

Salt Water (blue)

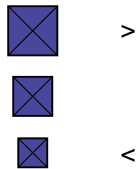

Fresh Water (cyan)



Water type unknown



Mud (tan)



Cuts (with appropriate symbol above)

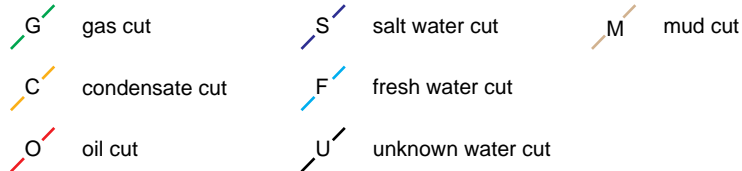

Miscellaneous (yellow)

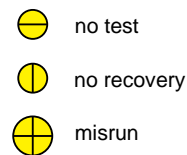

Interpretations

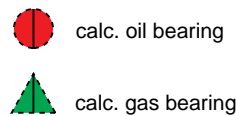

Example

Symbols may be combined to give more detailed information, e.g.



85 2935

Top reservoir at 2935 units; gross thickness 85 units; net reservoir 42 units.









42

Test flowed oil cut fresh water with lesser volume of mud.

2.0 WELLS AND HYDROCARBONS

2.1 Well Symbols on Maps and Sections

2.1.1 Surface Location Symbols













21101		Location proposed
21102		Surface location of isolated deviated well (for layer/horizon maps)
21103		Existing platform
21104		Proposed/planned platform
21105		Existing jacket
21106		Proposed/planned jacket
21107		Underwater completion template
21108		Existing platform with 40 slots and 16 drilled wells

2.1.2 Subsurface Location Symbols

The well symbol is composed to give information about 7 main elements, namely:





- Technical status
- Hydrocarbon status
- Production status
- Injection status
- Completion status
- Geological/structural information
- Type of well

2.1.2.1 Technical Status



212101		Location proposed	212108		Interpreted productive, technical status unknown
212102		Location on programme or approved, not yet drilled	212109		Technical status unknown
212103		Well declared tight by operator	212110		Supply well
212104		Drilling well	212111		Injection well
212105		Suspended well	212112		Dump flood
212106		Plugged and abandoned	212113		Through storage well - injects and produces seasonally
212107		Well closed in		TD	Total depth

2.1.2.2 Hydrocarbon Status



Shows

212201		Oil shows
212202		Gas shows
212203		Condensate shows
212204		Tar, bitumen shows

Interpreted productive

212205		Oil
212206		Gas
212207		Condensate

Proven productive

212208		Oil well
212209		Gas well
212210		Condensate well







The following letters may be used next to the well symbol to indicate the source of information used for the hydrocarbon status interpretation:

Ret	in returns
Ctg	in cuttings
C	in core
SWS / SWC	in sidewall samples / sidewall cores
L	by logs
TS	by temperature survey
WFT	by wireline formation tester
DST	by drillstem test
PT	by production test



2.1.2.3 Production Status

The following letters may be used next to a well symbol to indicate the conduit production method and status:

	Conduit		Method
GP	Gas producer	NF	Natural flow
GCP	Gas/condensate producer	BP	Beam pump
OP	Oil producer	ER	Electrical submersible pump
WP	Water producer	SP	Screw pump
GI	Gas injector	JP	Jet pump
OI	Oil (condensate) injector	HP	Hydraulic pump
PI	Polymer injection	GL	Gas lift
SI	Steam injection	PL	Plunger lift
WI	Water injection	IPL	Intermittent lift
		FL	Fluid lift
		PO	Power oil

212301		Well open to production from higher level than zone of map
212302		Well open to production from lower level than zone of map
212303		Zone of map exhausted; plugged back and opened to higher zone
212304		Zone of map exhausted; deepened to a lower zone
212305		Zone of map temporarily abandoned before exhaustion; plugged back and opened to higher zone
212306		Zone of map temporarily abandoned before exhaustion: deepened to lower zone

Wells closed in, productive or formerly productive

	(P)	Productive method when last produced
	(9-94)	Date last produced
	R	Closed in for repair
	NC	Closed in, non-commercial
	C	Closed in for conservation
	GOR	Closed in for high gas oil ratio
	W	Closed in for high water cut
	AB	Closed in awaiting abandonment
(11-93) Obs	Obs	Closed in for observation
	Fac	Closed in awaiting facilities

Formerly productive wells

212307		Formerly productive well, production now exhausted
212308		Well formerly produced from deeper level; plugged back to zone of map
212309		Well formerly produced from higher level; deepened to zone of map

Twin or multiple wells (distance apart too small to be shown on map)

M-75+76		Two or more wells drilled to different zones Zones of both wells represented on map
M-75+(76)		Only one zone represented on map
L-56+56A		Replacement well (numbering with suffix optional)

The top symbol corresponds with the first number and is placed on the actual location. The lower symbol is drawn immediately below and touching the top symbol. The method of numbering will allow differentiation from closely spaced wells (see following).

Closely spaced wells

	Plotted on their actual locations with their numbers against each well
--	--

Dual completions

212310		Both zones represented on map Higher zone on the right of the symbol
212311		Lower zone only represented on map
212312		Upper zone only represented on map

Simultaneous exploitation





212313		Well producing from zone of map together with higher levels
212314		Well producing from zone of map together with lower levels
212315		Well producing from zone of map together with higher and lower levels

Well sectors

		Sectors may be shown inside or outside of circle
212316		Well producing from top quarter of zone or highest of four zones represented
212317		Well producing from bottom third of zone, or lowest of three zones represented

Note: The zone is shown from top to bottom clockwise from the top of the circle.

2.1.2.4 Injection Status

212401		Gas injection well
212402		Water injection well
212403		Salt water disposal well
212404		Oil injection well
212405		Steam injection well



2.1.2.5 Completion Status

The following letters next to a well symbol indicate the completion status:

O	Open hole
GP	Gravel pack
Csg	Casing
L	Liner

2.1.2.6 Geological/Structural Information

General

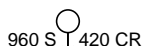
212601	 	} Unit/zone of map not reached Unit/zone of map missing
	f	Unit faulted out
	sh	Unit shaled out
	U	Unit missing due to unconformity
	WO	Unit wedged out
	IV	Invalid test (i.e. off structure)
212602		Well reaching caprock of salt dome
212603		Well reaching caprock and salt, depths of caprock and salt may be added

Formation dip

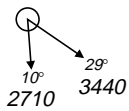

Oriented dipmeter readings; arrows point in the direction of dip: figures show angle of dip and depth of reading

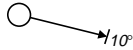

Length of arrow equal or proportional to contour spacing

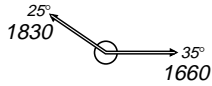

Oriented core dips

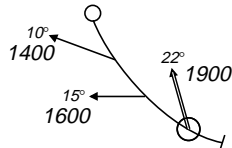

Oriented dips in deviated hole

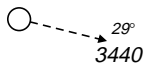

Dips unreliable

2.1.2.7 Type of Well

- Conventional well
- S ○ Slim hole
- CTB ○ Well drilled with coiled tubing
- SV ○ Service well (e.g. for water disposal)
- ^{CH-1} Core and structure holes (indicated by small circles), designed with either CH or SH
- _{SS} Site survey test hole

2.1.3 Deviated Holes

In case the well track is plotted without any geological information, a solid thin line indicates the surveyed well track and a dotted line the approximated one. The following conventions apply if additionally geological information is shown. These conventions have also been applied for horizontal wells; however, the conventions as set out in Section 2.1.4 (Horizontal Holes) are preferred.

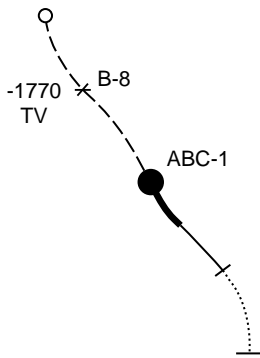

- Surface location
- Well track outside mapped reservoir, dashed
- Subsurface position of a marker
- Well number
- Subsurface position of top of producing zone or contour horizon
- Producing interval indicated by thick line (optional)
- Well track in non-producing reservoir, thin line
- Dotted line if the course of the hole is approximate or estimated
- Subsurface position of total depth

Note: To indicate whether true vertical or along hole depths are shown, the letters TV or AH, respectively, should be added. Alternatively, this may be shown in the legend.

Original hole vertical and sidetracked hole deviated

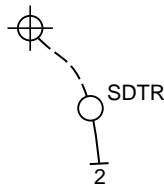

- Sidetracked hole deviated
- Subsurface position of mapped horizon
- Hole number near TD optional

Original hole and sidetracked hole deviated

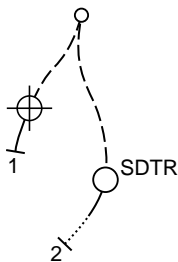

- The abbreviation SDTR is added to avoid confusion with twin or replacement wells.
- The holes may be given one well number or the second hole with a letter suffix according to circumstances.
- Hole numbers near TD optional

Wells directionally drilled from one platform

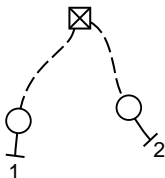

No vertical hole

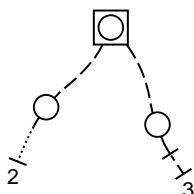

Vertical hole and one or more wells directionally drilled from one platform

Hole numbers near TD optional

2.1.4 Horizontal Holes

When plotting horizontal holes on maps, it is essential to plot the entire well track.

Plotting only a well symbol where the well enters and exits the reservoir, with both bearing the same well name, produces confusion.

As for conventional wells the symbol should carry the well identifier and depth of penetration of the horizon.

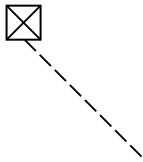

Surface location

Position of well track, dashed above/below the mapped reservoir

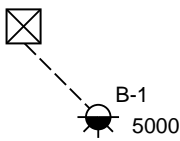

Standard well symbol indicates the intersection point of the well track with the mapped reservoir top whether it is penetrated from stratigraphically above or below.

The symbol should reflect hydrocarbons encountered by the entire well in the mapped horizon as per Section 2.1.2.

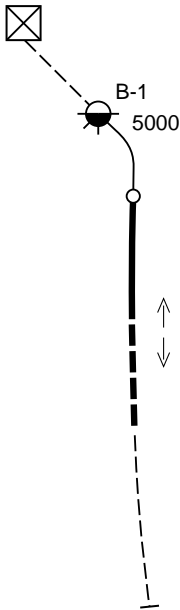

Solid thin line indicates the well is in the mapped reservoir.

A small circle may indicate the beginning of the horizontal hole section.

Solid thick line indicates the well is horizontal and in the mapped reservoir.

Dashed thick line indicates the well is horizontal and above/below the mapped top reservoir. Up/down arrows show whether the well has gone into the unit above or below the mapped one.

TD

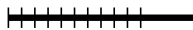

Completion zone (perforated) in the mapped reservoir

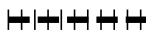

Completion zone (perforated) above/below the mapped reservoir



Pre-drilled liner

Example Schematic Cross-section

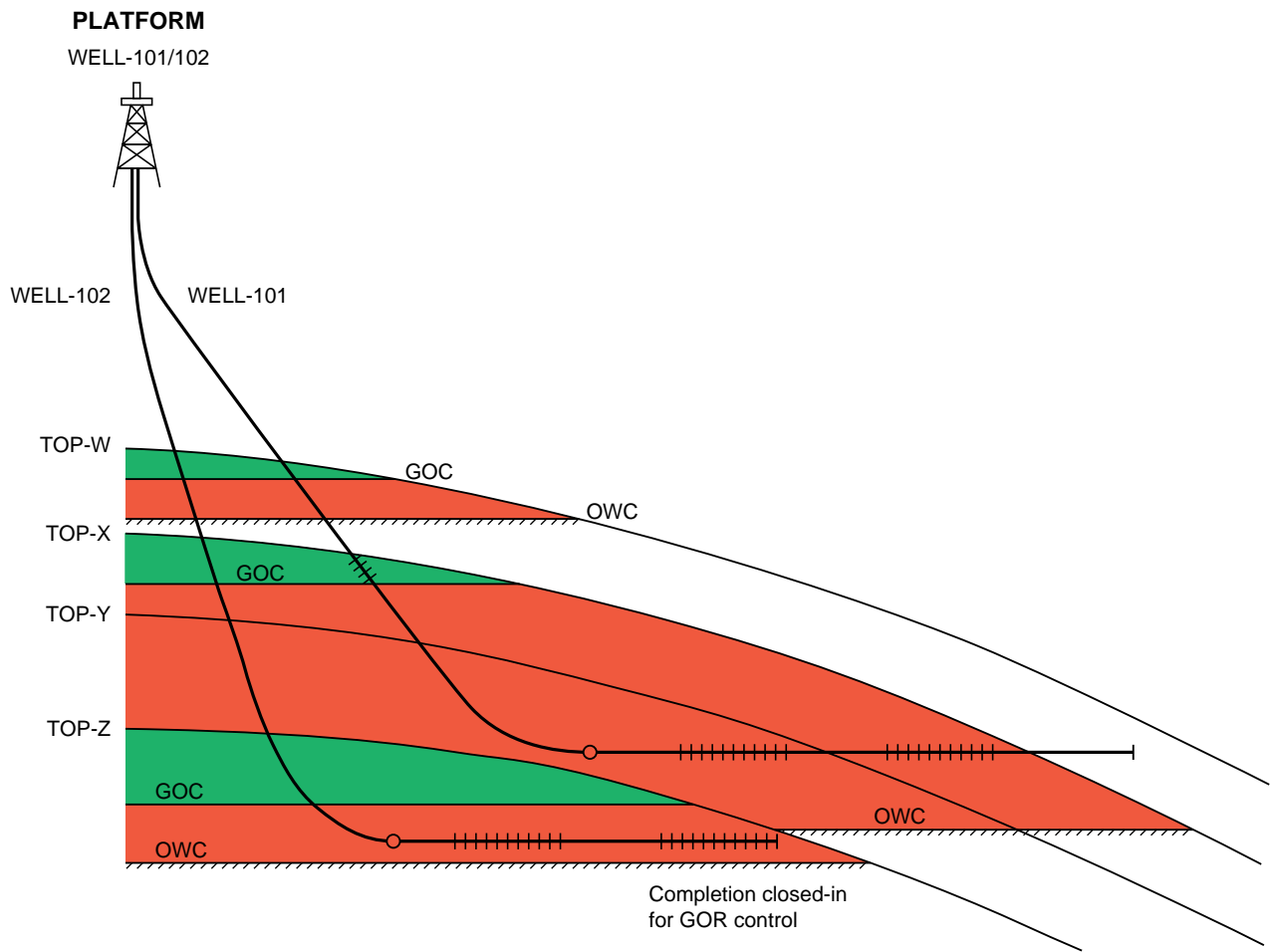

Map Symbols

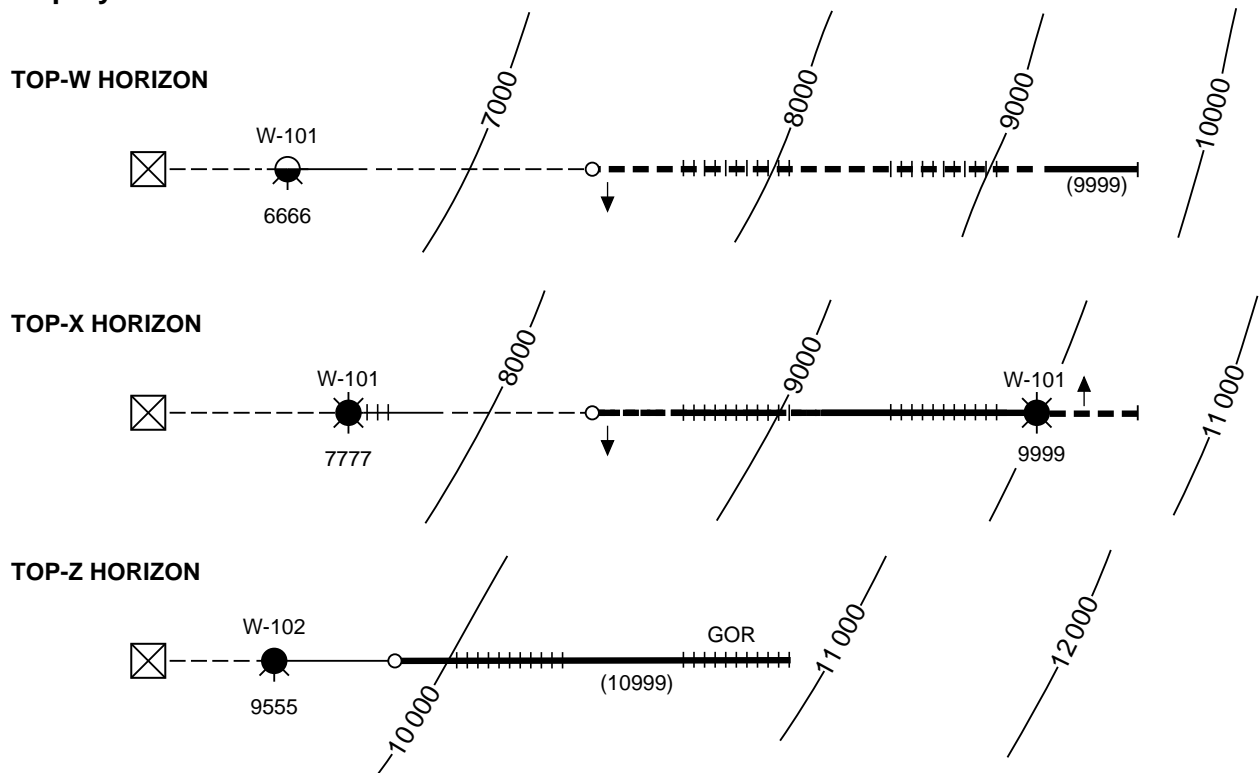

2.1.5 Multilateral Holes

When plotting multilateral holes, plotting the entire well track is essential.

As for conventional wells, the symbol should carry the well identifier and depth of penetration (TV DSS) of the horizon. In addition it should indicate the number of multilateral penetrations through the reservoir suffixed by the letter M or m.

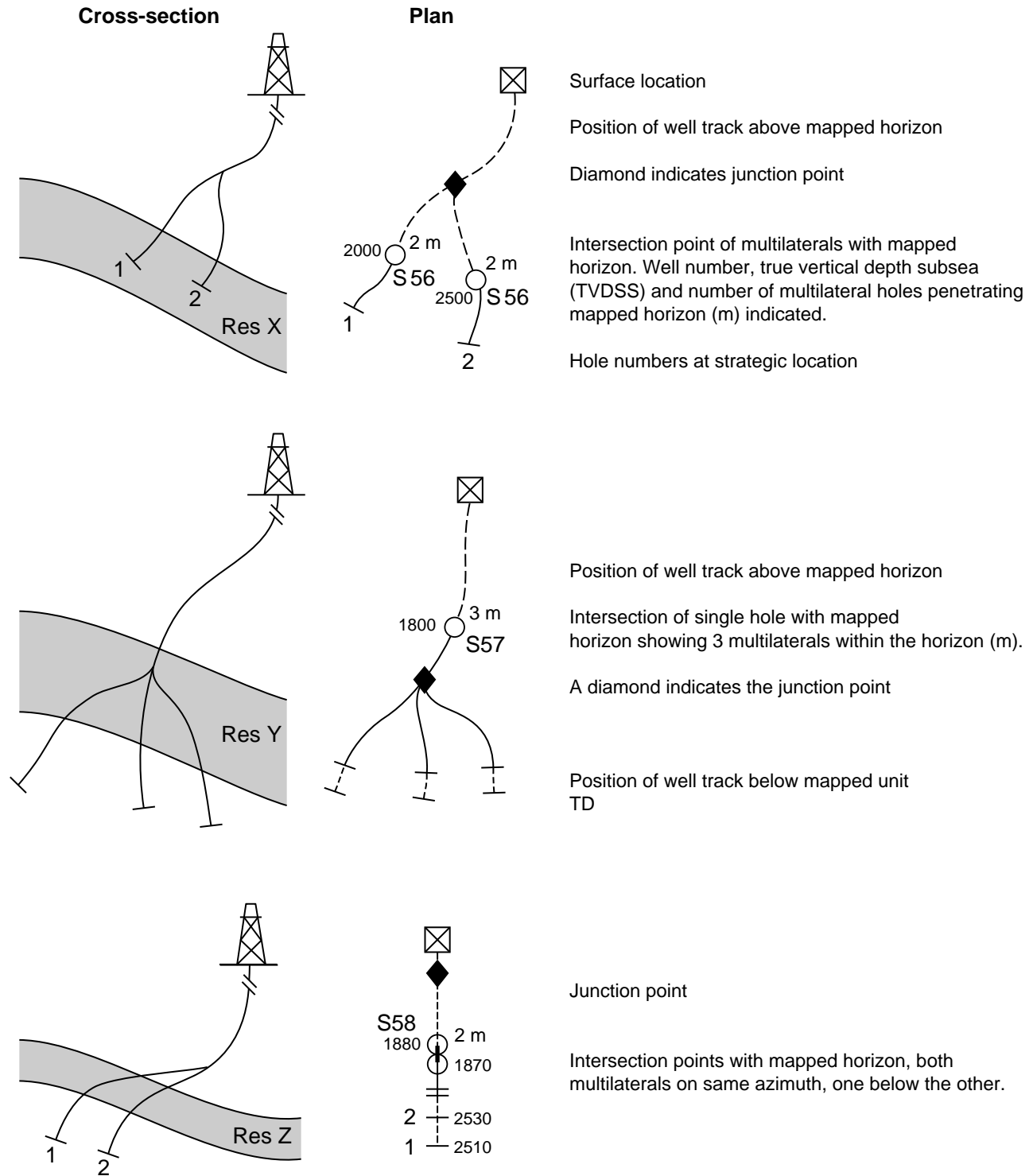

2.1.6 Multilateral Horizontal Holes

Cross-section

Plan

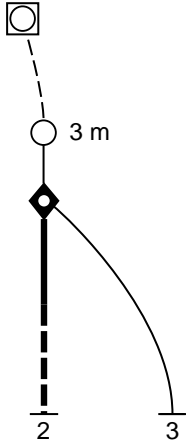
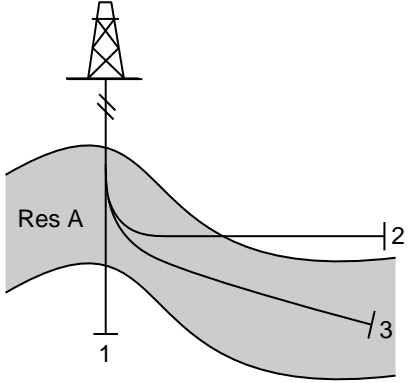

First vertical pilot hole
 Well path above/below mapped horizon
 Intersection of well with mapped reservoir
 Start of horizontal section
 Junction point of multilateral
 Horizontal and non-horizontal multilateral well path
 TD

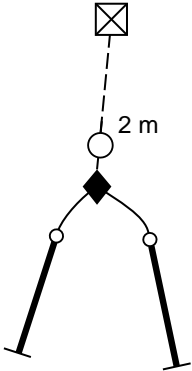
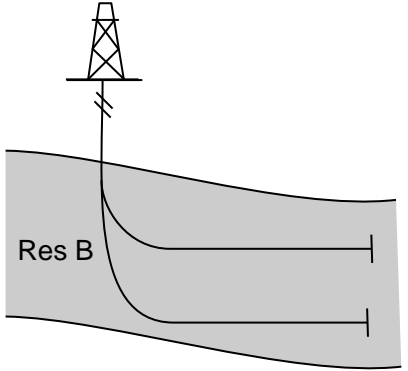

Intersection of well with mapped horizon
 Junction point
 Beginning of horizontal section
 Horizontal section in the reservoir
 TD

2.2 Well Bore Symbols

2.2.1 General Drilling Data

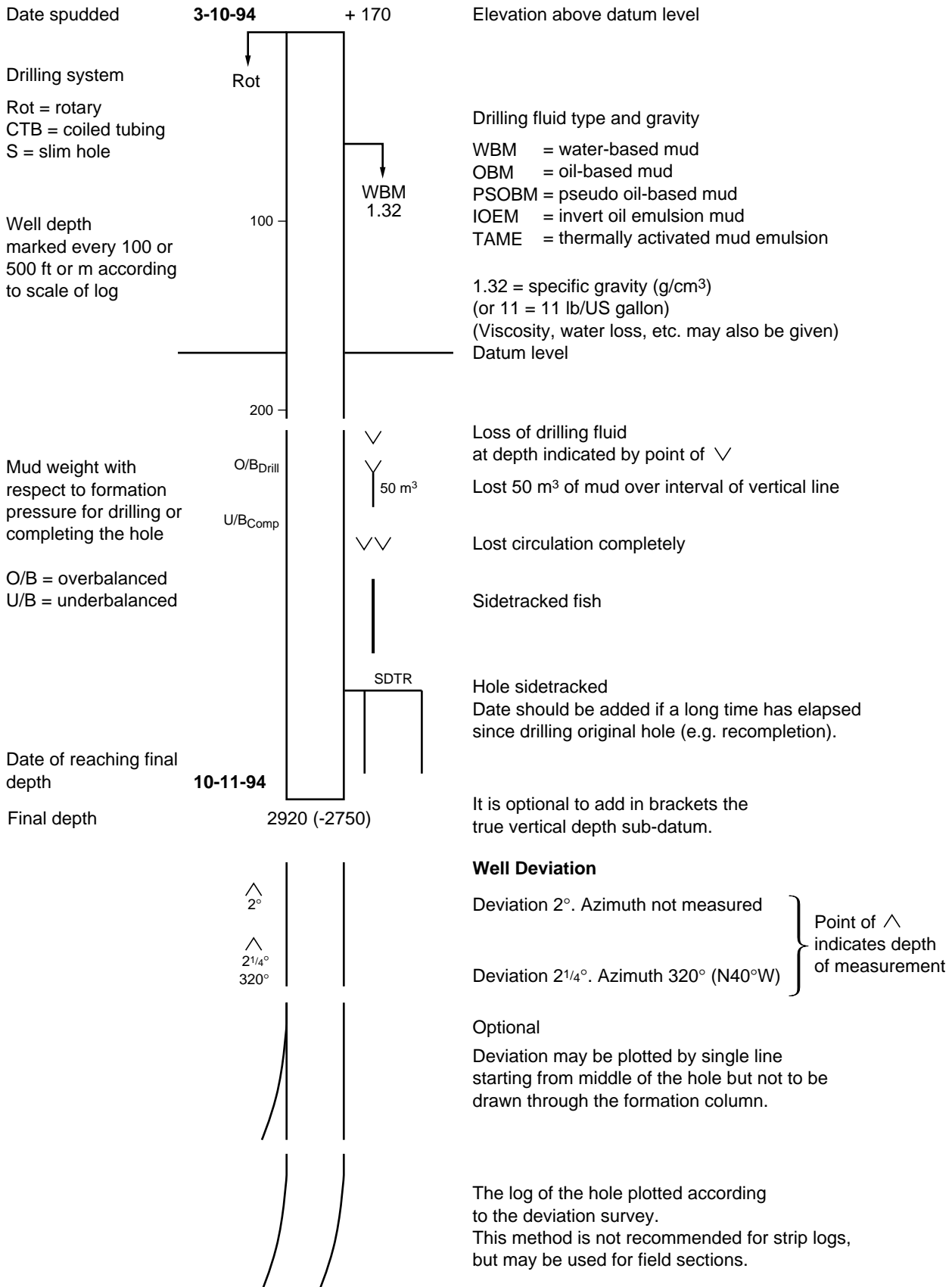

2.2.2 Formation Lithological Sampling and Dip Data

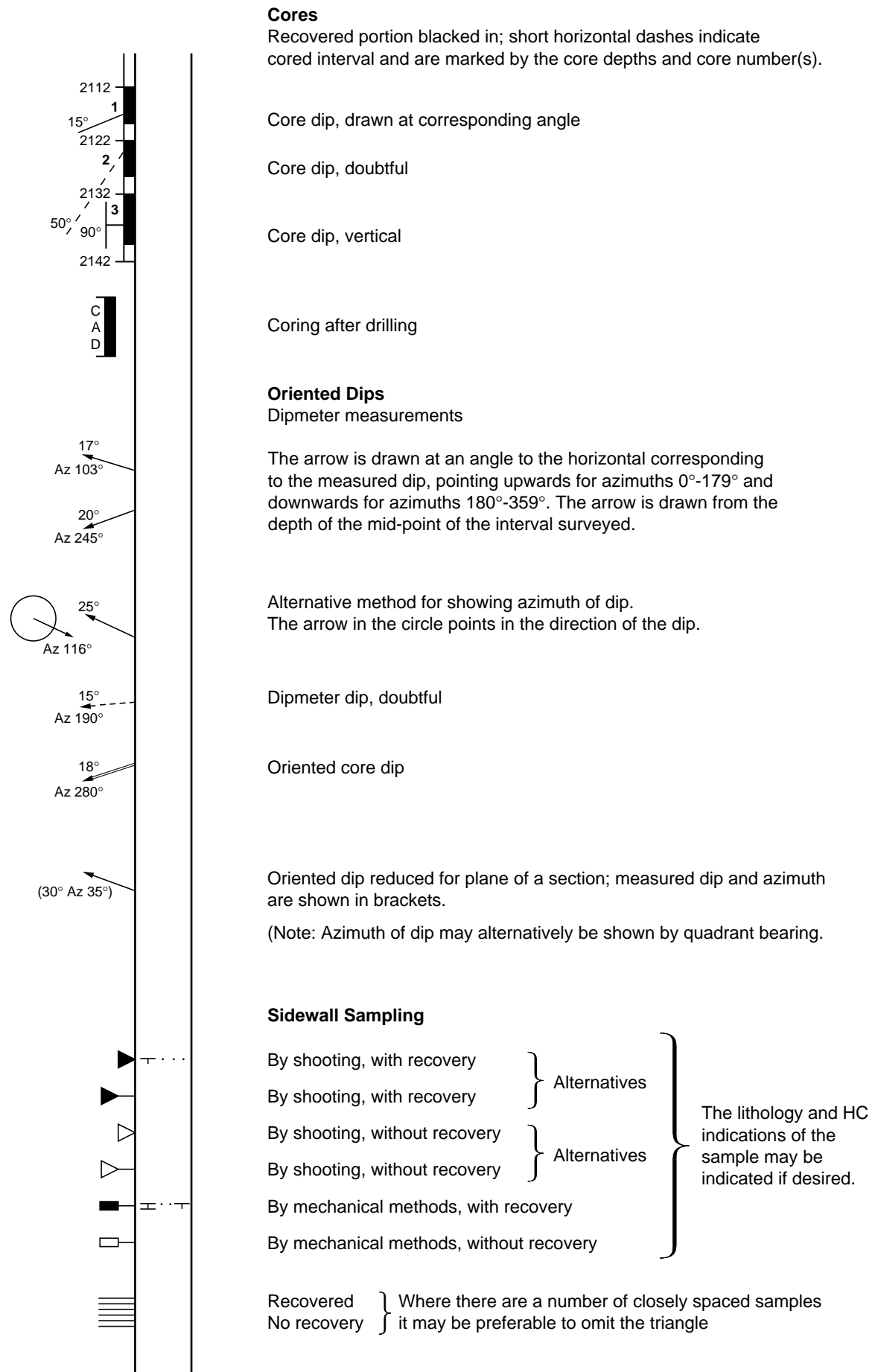

2.2.3 Casing and Cementations

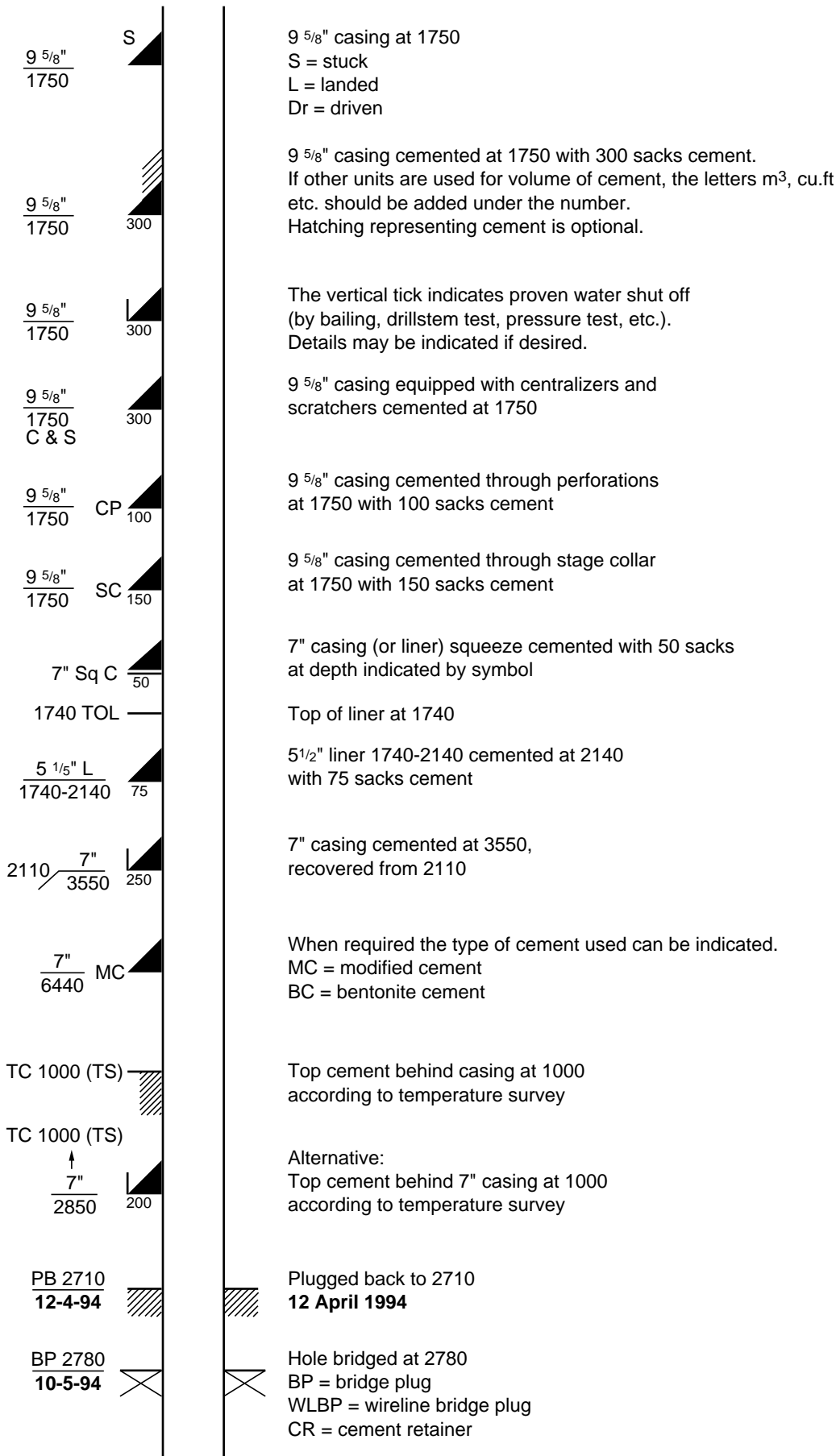

Engineering Symbols for Casing/Liner Accessories



Casing shoe/
Liner shoe

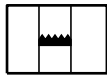

Top of fish

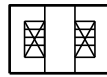

Perforations
squeezed

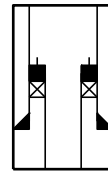

Liner packer hanger
(with tie back
extension)

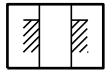

Top of cement
behind casing/liner

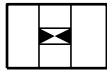

Bridge plug

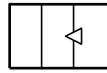

Hole left after
FIT-open

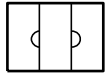

Cement valve
(DV FO or reverse
plug cutter)

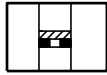

Through Tubing
Bridge Plug

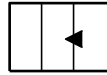

Hole left after
FIT-squeezed off

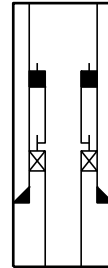

Liner hanger with
tie back packer
(and tie back
extension)

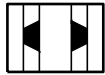

Open hole packer
set in casing/liner

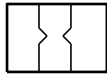

Collapsed casing/
liner

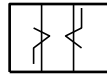

Casing/liner leak
below/above

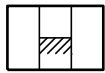

Top of cement

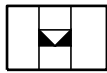

Cement retainer

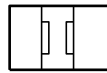

Internal casing
patch

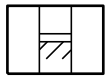

Top of plug/float

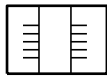

Perforations open

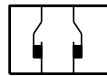

External casing patch

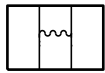

Top of fill

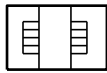

Perforations plugged

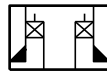

Liner hanger
(with tie back
extension)

2.2.4 Completion Methods

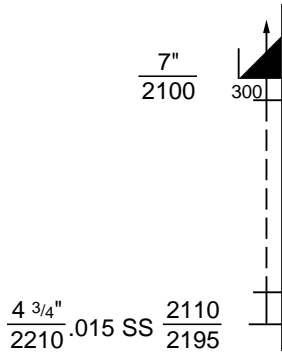

Full Oilstring

Blank pipe within the slotted section should be shown in a similar manner to the blank pipe above and below the slotted section.

4 3/4" full oilstring with .015" saw slots 2110-2195

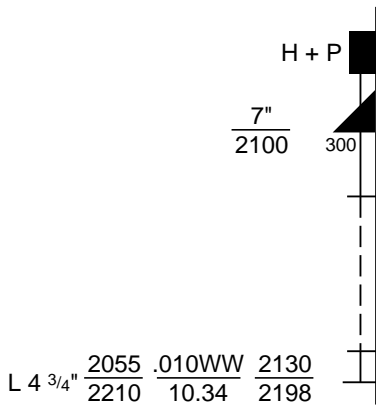

Liner

H = liner hanger
P = packer or seal

4 3/4" liner 2055-2210 with .010" wirewrapped screen 2130-2198; screening area (10.34 sq. in. per ft) may be indicated if desired.

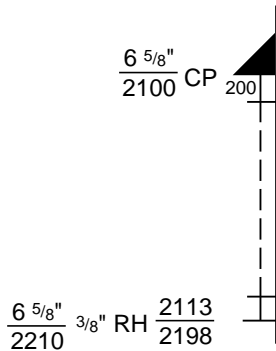

Combination String

6 5/8" combination with 3/8" round holes 2113-2198

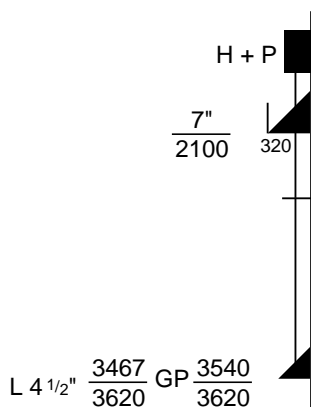

Gravel Packing

4 1/2" liner 3467-3620 gravel packed 3540-3620

$\frac{9 \frac{5}{8}''}{2000}$

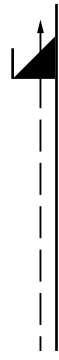

Barefoot 8 1/2''
2100

Barefoot

8 1/2" open hole from 9 5/8" casing at 2000 to TD at 2100

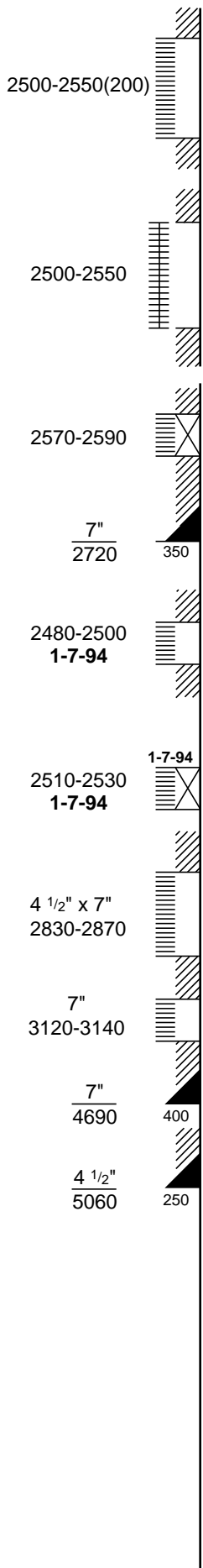

Perforation

Casing perforated 2500-2550 with 200 shots. The number of shots and the hatching representing cement are optional.

Casing perforated; alternative symbol

Perforated interval (2570-2590) cemented off

When an interval is perforated or cemented off an appreciable time after the original completion, the dates may be added as shown.







When more than one string of casing is cemented over the perforated interval, the casing sizes should be indicated.

Dual Completion

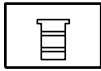
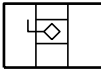
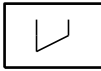
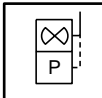
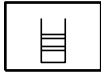
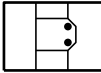
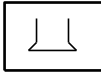
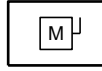
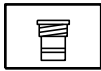
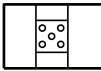
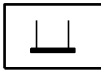
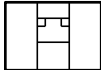
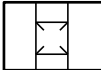
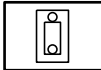
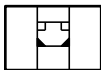
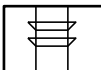
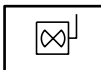
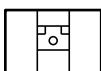

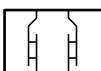
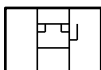

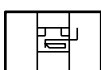
Isolating packer at 2310
 Each productive interval should be indicated by a separate production symbol and fraction (see 2.2.6).

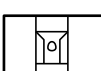
2310

Engineering Symbols for Tubing Accessories

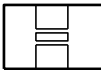
	Locator seal		Permagauge		Half mule shoe		Pressure sensing instrument (PSI) connected to ESP
	Spacer seal		SPM		Re-entry guide		Pump motor
	Anchor latch seal		Perforated nipple		Blanked off shoe		
	X nipple		X-over (Same size/different connection)		Pump (Type defines rod/tbg retrievable e.g. TH, RHAC etc.)		
	XN nipple		Gas anchor		Pump ESP		
	SSD		Seal bore extension		Tubing expansion joint		
	SC SSSV (Ball or flapper type)		Flow coupling		X-overs (change in tbg size)		
	Solenoid Safety valve		Blast joint		X-overs (change in tbg size)		
			Perforated nipple and straddle				

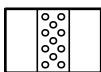
Completion Liner Symbols

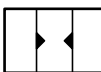
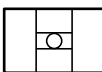
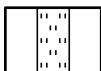
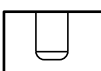
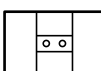
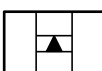
	Wire wrapped screen		Tell tail (WWS)		Gravelpack Seal bore sub		Shear sub
	Perforated liner		Tell tail (slotted)		Gravelpack O-ring sub		Drain valve
	Slotted liner		Bullnose		Gravelpack ports		Check valve

Completion Packer Symbols

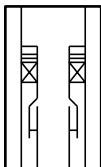
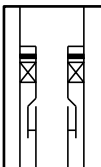
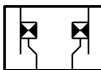
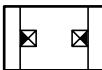
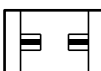
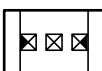
	Model 'D' liner hanger/packer with overshot tie back (Retrievable packer w/out tubing seal)		Wolverline hanger/packer with overshot tie back (Retrievable packer w/tubing seal)		Permanent type production packer (w/mill out ext.)		Hydraulic production packer (integral w/tbg)
					Retrievable prod. packer (w/tbg seal)		Dual hydraulic packer

2.2.5 Formation Treatment

Acid Treatments

Arrow points to bottom of interval treated

Single Treatment

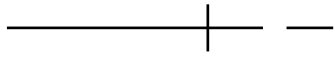
AT $\frac{1500}{1580}$ 5000 gal 10% HCl 
(Standard fraction, see 2.2.6)

Interval 1500 to 1580 treated once with 5000 gallons 10% hydrochloric acid

Multiple Treatments

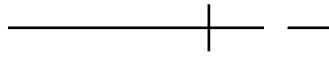
AT x 3 $\frac{1740}{1800}$ 40 m³ 15% HCl + 3% NH₄ (HF₂) 

Interval 1740 to 1800 treated three times with a total of 40 m³ 15% hydrochloric acid with 3% ammonium bifluoride

AT ①②③ $\frac{1600}{1950}$

Interval 1600 to 1950 treated three times. Details and test results given at foot of column

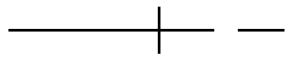
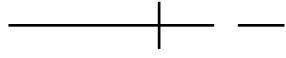
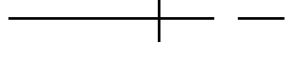
AT ① $\frac{1600}{1950}$ 2500 gal 10% HCl 
 AT ② $\frac{1600}{1950}$ 3500 gal 12% HCl 
 AT ③ $\frac{1600}{1950}$ 5000 gal 15% HCl 

Fracture Treatments

Arrow points to bottom of interval treated

FRAC $\frac{2980}{3070}$

Formation fractured

FRAC = unspecified fracturing

SF = sand-frac

AF = acid-frac

Further details of the treatment may be added as required, e.g.

FRAC $\frac{3000}{3040}$ 300 B + 10,000 lb Sand 

Shooting

Interval indicated by symbol shot with 80 quarts nitroglycerine

 80 qt

2.2.6 Production Test Results and Data

Production and Drillstem Tests

Tests should be numbered in chronological order.

Roman numerals ①, ②, etc. may be used for drillstem tests in open hole and arabic numerals ⑤ for tests inside casing.

It is optional to place test results alongside the interval tested, where space permits, or to list all test data at the foot of the log.

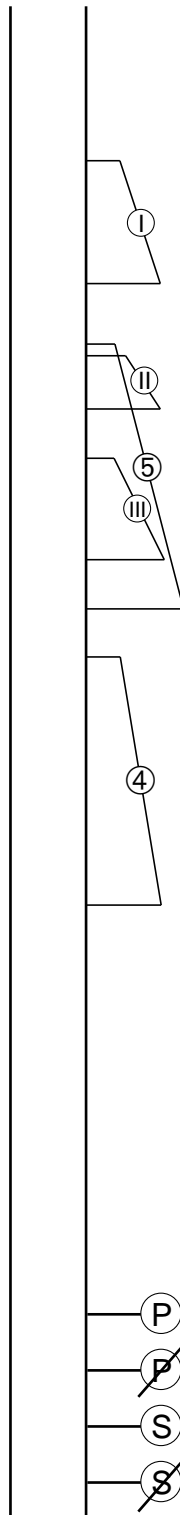

$\frac{3140}{3240}$ ① DST 60 min 90' GCM (1-94)

A more complete fraction may be used to give fuller details as required. Examples of very complete fractions are given on the next page.

Overlapping or closely spaced test results given at foot of log (see below)

When flowing production is obtained from production tests, the standard fraction may be used :

$\frac{3800}{4000}$ PT $\frac{90\text{BO} + 10\text{BW} (3/8)}{12 \text{ hrs}}$ | $\frac{45\text{BO}}{1-94}$ | $\frac{.850}{1-94}$

Depth bdf top interval open to production	PT	Initial production (choke) daily rate	Total oil production during test	Gravity of oil
Depth bdf base interval open				Duration of test

The final completion is indicated by the oil well symbol (or gas or condensate well symbol) at the bottom of the interval open to production.

● $\frac{3810}{4220}$ ———— | ————
(Standard fraction)

Formation Pressure and Fluid Sampling

- Ⓟ 4 kpa Pressure reading, successful
- Ⓟ Pressure reading, failed
- Ⓢ Sample, successful, chamber size and recovery at bottom of document
- Ⓢ Fluid sampling failed

Note :

- open hole
- cased hole

② $\frac{3400}{3440}$ DST 40 min 750' oil .890 (1-94)

③ $\frac{3480}{3560}$ DST 50 min 500'W 11,000 ppm Cl(1-94)

⑤ $\frac{3390}{3600}$ Sw 4d est 10 b/d oil .907; 5 b/d water 9,000 ppm Cl (2-94)

Ⓢ Chambers : 1 gal/2³/₄ gal recovery : 2l oil (40 API)
23 cu ft gas
1l water (sal. 34,000 ppm)

Examples of Very Complete Test Fractions

Tests that flow

I)	DST 2-94	6780 6860 (7150)	4 hrs 3 hrs GTS-14 min OTS-45 min	*135 BO + 15 BW (10%) + R-742 ** 2,000 ppm ** 40,000 ppm	IFBHP/FFBHP 200/900 SIBHP 3800/15 min HP 4000	3/8"x1" 38°
	DST	Top of interval tested	Duration of test	* Total production measured during flow period (water expressed as volume followed by percent total fluid in parenthesis)	+ Gas-oil ratio	B.H. Choke x Top choke size
Number of test	Date of test	Bottom of interval tested (Bottom of hole at time of test optional)	Time during which flow was measured GTS, OTS	** Titration of drilling fluid-ppm ** Titration of produced water-ppm	Pertinent pressure data + units	Gravity of oil

Tests that do not flow

IV)	DST 2-94	6860 6940	128 min GTS-95 min	200' (2.6 B) O + 200' (2.6 B) HOCM + 600' (7.7 B)W ** 2,000 ppm (r) ** 40,000 ppm	IFBHP/FFBHP 0/700 SIBHP 1800/15 min HP 4000	3/8"x1" 38°
-----	-------------	--------------	-----------------------	---	---	----------------

- * It is optional to express flow as daily rate figure indicated by placing (DR) in front of oil production.
 ** Titrations should be given as ppm soluble chlorides. If salinity is given as NaCl, or if other units are used, it should be so stated.
 If salinity is obtained by resistivity instrument, denote by (r) as shown in DST no. IV.

Abbreviations for use in test fractions

min	=	minutes	FL	=	fluid level
hrs	=	hours	F	=	flowed
d	=	days	Sw	=	swabbed
DR	=	daily rate	BI	=	bailed
B	=	barrels	P	=	pumped
m ³	=	cubic metres	GL	=	gaslift
O	=	oil	AL	=	air lift
C	=	condensate	BHP	=	bottom hole pressure
G	=	gas	IFBHP	=	initial flowing BHP
W	=	water	FFBHP	=	final flowing BHP
WC	=	water cushion	ISIBHP	=	initial shut in BHP
M	=	mud	FSIBHP	=	final shut in BHP
GCM	=	gas cut mud	SIBHP/15 min	=	shut in BHP after 15 minutes
OCM	=	oil cut mud	HP	=	hydrostatic pressure
GOCM	=	gas and oil cut mud	IFSP	=	initial flowing surface pressure
WCM	=	water cut mud	FFSP	=	final flowing surface pressure
SWCM	=	salt water cut mud	GTS	=	gas to surface
SIOCM	=	slightly oil cut mud	MTS	=	mud to surface
HOCM	=	heavily oil cut mud	OTS	=	oil to surface
ppm	=	parts per million	WCTS	=	water cushion to surface
GCG	=	grain NaCl per gallon	GOR	=	gas/oil ratio
			GCR	=	gas/condensate ratio

A fraction similar to the standard production fraction may be used for longer tests.

An example would be

2)	9-2-94	7680	400 (16) BO + 10 BW + R-340	1640	40°	
	F	7690 (8600)	200 (16) BO + 7 BW + R-420	6		
Number of test	Date test commenced	Top of interval tested	Production during first 24 hours	+ GOR	Total oil recovery during test	Gravity of oil
	Method of production	Bottom of interval tested (Total depth optional)	Production during last 24 hours	+ GOR	Length of test in days	

2.2.7 Lithology

The lithology of cored and side wall sampled intervals of production wells is plotted in the centre column of the log using the appropriate symbols shown in 4.2 and 4.3. The lithology of the remaining sections may be plotted from the drill cuttings, if desired.

The latter is standard in exploration wells and a short lithological description is added on the right side of the lithological column.

2.2.8 Hydrocarbons, Gases and Waters

Indications of gas, oil and water are plotted on the right side of the lithological column using the appropriate symbols as shown below.

2.2.8.1 Gas

The type of gas, if known, may be indicated:











B biogenic, bacterial

T thermal

TH thermal: humic source

Tk thermal: kerogenous source

Subsurface
(Well logs)

	Smell in general	
	Faint smell	} See Section 1.1 "Rules for Abbreviations" points 9 and 10
	Strong smell	
	Smell of hydrogen sulphide	
	Weak gas seepage, gas show (inflammable gas) Tail of arrow indicates position	
	Ret = in returns	
	Ctg = in cuttings	
	C = in core	
	SWS/SWC = in sidewall sample/sidewall core	
	Strong seepage, show (inflammable gas)	
	Non-inflammable gas	
	Blow-out	
	Gas, CO ₂ (CH ₄ , H ₂ S, etc.) predominant	
	Interpreted as gas productive Main source of evidence on which interpretation is based may be added, if desired.	
	TS = by temperature survey	
	PT = by production test	
	EL = by electrical logs	
	DST = by drillstem test	
	Ret, Ctg, C, SWS: see above	
	Proven gas productive	} Fraction for drillstem or production test should be shown (see 2.2.6)
	Proven condensate productive	
	Gas producing interval	} See 2.2.6
	Condensate producing interval	

2.2.8.2 Oil

(Well logs)

	◇	Smell in general	
	○	Weak show, stains	
	○ ○ SWS	Strong show SWS, etc.: see 2.2.8.1	
	↑	Heavy, tarry and dead oil	
	○ EL	Interpreted as oil productive	} Main source of evidence on which interpretation is based may be added if desired ; see 2.2.8.1
	○ ●	Interpreted as oil or gas productive	
	●	Proven oil productive (fraction for drillstem or production test should be shown; see 2.2.6)	
	●	Oil producing interval (see 2.2.6)	

2.2.8.3 Solid Hydrocarbons

Subsurface
(Well logs)

	Bit	Bitumen, (bituminous formation = bit)
	▲	Asphalt
	●	Mineral wax (ozokerite, etc.)
	○	Asphaltite (gilsonite, etc.)

2.2.8.4 Formation Waters

(Well logs)

×	Salt water	} In case of thermal water add "T" or temperature
+	Fresh water	
+ H ₂ S	Fresh water with H ₂ S	
×	Interpreted as salt water productive. See also 2.2.8.1 for evidence. This symbol should be used whenever it refers to observations made on cores, sidewall samples and cuttings. When based on electric log, drillstem or production tests its use is optional.	
 sws		
×	HFW	Hole full of salt water
⌘		Salt water flowing
⌘		Fresh water flowing
×	Cl 8540	Water with 8540 ppm chloride ion concentration
⊗	Proven salt water productive; fraction for drillstem or production test should be shown (see 2.2.6).	} It is optional to add this symbol.

Examples of combination of indications

⌘	Gas and salt water
⊙	Gas and oil seep or show
⊙ ⊙	Strong oil seep or show with gas
⊙ →	Oil and gas blow-out

2.2.8.5 Vintage Hydrocarbon Show Symbols

The following symbols - now obsolete - are shown here, since they have been widely used in the past and are found on vintage completion logs.

⋮	⋮	⋮ Ctg	Colour of solvent cut (ether, chloroform, carbon tetrachloride)
: Flu SWS	: Flu	: Flu	Fluorescence of solvent cut under ultra-violet light
· Acet	· Acet Ctg	· Acet	Acetone/water cloud test

It is optional to indicate the type of material tested;

C = core

SWS/SWC = sidewall sample/sidewall core

Ctg = cuttings

2.3 Hydrocarbon Show Reporting

Hydrocarbon indications are **ditch gas** readings and **oil shows** in cuttings, sidewall samples and cores.

Oil shows are reported by the "Zulu-Zero (Z0Z000)" code. Each position in this code (from left to right) indicates one result from each of the following tests:

Natural Fluorescence - Distribution

A = even
B = streaked
C = spotted (patchy)
Z = none

Natural Fluorescence - Intensity

3 = bright (good)
2 = dull (fair)
1 = pale (weak)
0 = none

Natural Fluorescence - Colour

A = white
B = blue
C = yellow
D = gold
E = orange
F = brown
G = coffee
Z = none

Solvent (Chloroethene CH_2Cl_2) Cut - Colour

A six- and an eightfold subdivision of the colour gradation are used.

7 = black
6 = coffee
5 = brown
4 = tea
3 = straw yellow
2 = light yellow
1 = traces
0 = nil (pure solvent)
5 = dark coffee
4 = dark tea
3 = normal tea
2 = light tea
1 = very light
0 = nil (pure solvent)

Cut Fluorescence - Intensity

3 = bright (good)
2 = dull (fair)
1 = pale (weak)
0 = none

Acetone Reaction

4 = milky (good)
3 = opaque white (fair)
2 = translucent white (weak)
1 = traces (faint)
0 = nil (clear)









Examples

Natural fluorescence - distribution	none = Z	Solvent cut - colour	nil = 0
Natural fluorescence - intensity	none = 0	Cut fluorescence - intensity	none = 0
Natural fluorescence - colour	none = Z	Acetone reaction	nil = 0
No oil shows: Z0Z000			



Natural fluorescence - distribution	even = A	Solvent cut - colour	light yellow = 2
Natural fluorescence - intensity	bright = 3	Cut fluorescence - intensity	bright = 3
Natural fluorescence - colour	yellow = C	Acetone reaction	milky = 4
Good shows of a rather light oil: A3C234			

2.4 Hydrocarbon Fields and Prospects on Maps and Sections, Colour Coding



Exploration

	yellow & white	Lead
	yellow	Prospect
	red	Oil field
	green	Gas field
	orange	Wet gas, gas-condensate field
	cyan	Water filled structure
	red & green	Oil field with gas cap
	green & red	Gas field with oil rim

Pre-production

	red & white	Oil field, pre-production; in reservoirs where there is an ODT and WUT
	green & white	Gas field, pre-production; in reservoirs where there is an GDT and WUT

Post-production

	red & cyan	Oil field, post-production; in reservoirs where the original OWC has moved, indicating encroachment of oil by water from original to current OWC
	green & cyan	Gas field, post-production; in reservoirs where the original GWC has moved, indicating encroachment of gas by water from original to current GWC
	red & green	Oil field with gas cap, post-production; in reservoirs where the original GOC has moved, indicating encroachment of oil by gas

The name of an abandoned field is shown on maps in brackets.

Notes: Colour coding of oil and gas fields in the US and in the North Sea (outside Shell) is the opposite - oil is green and gas is red, and consequently this colour coding is also widely used by petroleum geological publishing houses.

Adapting this colour coding would understandably cause misunderstandings, and additional costs in production departments for changing colours on maps and sections.

Whenever publications or lectures are directed at a not exclusively European Shell audience, it is recommended to indicate the colour code used in a legend. Water is always shown in blue.

For colours see Appendix 4

Oil, Gas and Water on Subsurface Maps and Sections

Maps

On subsurface contour maps of a producing layer the OWC and the GOC are normally shown. Where exploration has changed these levels, their level at the date of the map should also be shown.

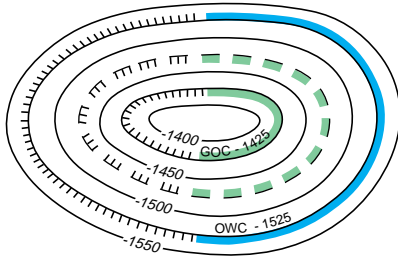



- Contours on top of producing layer
- ▬▬▬▬▬ Intersection of original gas-oil contact at -1425 with top of producing layer
- ▬▬▬▬▬ Intersection of original oil-water contact at -1525 with top of producing layer
- ▬▬▬▬▬ Intersection of gas cap at date of map with top of producing layer

Note: Hachures or colour may be used optionally; it is not necessary to use both.

Section

Whenever possible the accumulation of oil and gas should be clearly indicated on sections through oil and gas fields.

















Abbreviations

OWC	Oil/water contact		GUT	Gas up to
GWC	Gas/water contact		HDT	Hydrocarbons down to
GOC	Gas/oil contact		HUT	Hydrocarbons up to
GLC	Gas/liquid contact		WDT	Water down to
ODT	Oil down to		WUT	Water up to
OUT	Oil up to		FWL	Free water level
GDT	Gas down to		OWC	Original oil/water contact etc.











2.5 Surface Hydrocarbon and Water Seeps (Shows) on Maps

Colours are recommended, but not obligatory.







2.5.1 Gas

Group of Indications	Single Indication	
		Smell in general
		Faint smell
		Strong smell
		Smell of hydrogen sulphide
		Gas seepage, gas show Tail of arrow indicates position
		Weak seepage
		Strong seepage, show
		Inflammable gas
		Non-inflammable gas
		Gas, CO ₂ (CH ₄ , H ₂ S, etc.) predominant





2.5.2 Oil

Group of Indications	Single Indication	
		Smell in general (see also above)
		Seepage in general
		Poor seepage
		Strong seepage
		Oil seepage reported by geologist "R", could not be relocated
		Heavy, tarry and dead oil. In outcrops: impregnation without free oil

2.5.3 Solid Hydrocarbons

Group of Indications	Single Indication	
		Asphalt
		Large asphalt seepage, asphalt lake
		Mineral wax (ozokerite, etc.)
		Asphaltite (gilsonite, etc.)





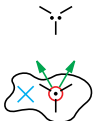
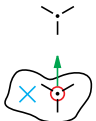

2.5.4 Surface Water Springs, Seepages

Group of Indications	Single Indication	
		Salt water
		Fresh water
		In case of thermal water add "T" or temperature

2.5.5 Mud Volcanoes

Group of Indications	Single Indication	
		Mud volcano without indications of hydrocarbons
		Mud volcano with gas, oil, salt water and boundary of mud flow. The latter may be omitted.

Examples of combinations of indications

		Gas and salt water
		Gas and oil seep or show
		Strong oil seep or show with gas

3.0 TOPOGRAPHY

The purpose of this legend is to provide standard symbols for frequently occurring and important features.

Local (national) standards may make it desirable to deviate from this legend, but such deviations should be kept to a minimum.

Symbols are of standard size, and consequently never true to scale.

For larger-scale maps, where features can be shown at map scale, the use of symbols should be limited and mainly restricted to indicate characteristics of areas (marshes, etc.) or lines (fences, power lines, etc.). It may also be advantageous to give a description in words for these larger scales.

3.1 Survey Datum

The following information shall be displayed on all maps. The projection system information must contain all projection parameters (see Section 6.1.1, Example of Seismic Map).

Co-ordinate System Definition

Map Projection :
Spheroid :
Geodetic Datum :
Horizontal Units :











The following Datum information shall be displayed on all maps containing contour, height or bathymetry data.

Vertical Datum

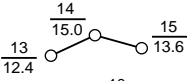

Height : Bathymetry :
Unit : Unit :

3.2 Survey Reference Points





3.2.1 Horizontal Control Points

	$\frac{AS\ 25}{140}$	Astronomic station	$\frac{\text{number}}{\text{altitude}}$
	$\frac{T\ 12}{65}$	Triangulation or traverse pt.	$\frac{\text{number}}{\text{altitude}}$
	$\frac{T\ 15}{122}$		id. (first-order accuracy)
	$\frac{T\ 18}{42}$		id. (second-order accuracy)
	$\frac{T\ 22}{11}$		id. (third- and lower- order accuracy)
		Polygon/traverse points	$\frac{\text{number}}{\text{altitude}}$
	$\frac{10}{11.3}$		id. (first-order accuracy)
	$\frac{16}{8.1}$		id. (second- and lower-order accuracy)
	S1	Satellite fix point	
	S44		id. (first-order accuracy)
	S12		id. (second-order accuracy)

3.2.2 Vertical Control Points

	$\frac{BM\ 12}{15.4}$	Levelling benchmark	$\frac{\text{number}}{\text{altitude}}$
	.425	Spot elevation	

3.2.3 Other Position Markers

	Boundary marker
	Control point of aerial photo, satellite imagery and number
	Position from which photo or sketch was made
	Topographical position uncertain

3.2.4 Survey Control Lines (for trig. diagrams)

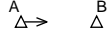
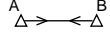
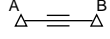
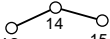
	Direction AB measured
	Directions AB and BA measured
	Distance AB measured
	All angles and distances measured

3.3 Boundaries



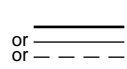
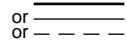
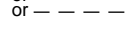

3.3.1 Political Boundaries

- +++++++ **International**
- + - - - + - - + **Administrative** (provinces etc.)
- + - - - + - - + **Offshore boundaries** (mid-coastline etc.)



3.3.2 Concession Boundaries (also leases, permits, licenses etc.)

-  { **Shell concessions** Percentage of participation may be indicated
- or  { **Competitor's licenses** May be further differentiated
- or 

3.3.3 Area Limits Offshore

-  { Baseline for seaward boundary definition
- or  { 3-mile limit
- or  { 12-mile limit
- or  { 200-mile limits (others may be defined)
-  Shipping lanes, anchoring restrictions, dumping areas, prohibited or restricted areas

3.3.4 Area Limits on Land

- or  **Property boundary**
-  **Government reserves** (defence etc.)
-  **National parks**

3.4 Artificial Features

3.4.1 Linear Features

Roads, railroads etc.

	Primary road
	Secondary road
	Track
	Footpath, trail
	Railroad
or	
	Tunnel

Overhead lines

	Tel	Telephone line
	11 kV	Power, indicate voltage, e.g. 11kV or HT

Buried or non-exposed lines

	Tel	Telephone
	HT	Power
		Submarine cable

Pipelines (exposed)

	24"	Oil (crude) (indicate size) Red
	24"	Products (indicate size) Orange
	12"	Gas (indicate size) Green
	4"	Water (indicate size) Blue
	20"	Sewage (indicate size) Brown
		Buried pipelines (differentiate as for exposed lines)

Area separations

	Fence
	Hedge
	Stone wall

Outline of area

	Limit of built-up area
--	------------------------

3.4.2 Point Features

Towns



Town



Buildings

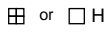

Hospital



Church, temple



Mosque



Post, telephone, telegraph office



Military (police) post



Motor fuel station

Towers etc.



Monument



Water tower



Windmill



Lighthouse



Radar station
Radio (television or telecommunication transmitter station)
Radio beacon

River features

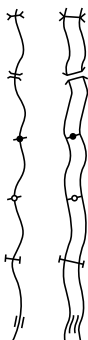

Bridge for pedestrians

Bridge for general traffic

Ferry for pedestrians

Ferry for general traffic

Dam

Sluice

3.4.3 Area Features (Sites etc.)

Industrial sites



Refinery



Tankfarm



Pumping station



Quarry (Lst = Limestone)







Mine (C = Coal)



Traffic sites

	Airport, airstrip
	Heliport
	Jetty

Communal sites





	Christian cemetery
	Islamic cemetery
	Chinese cemetery
	Park
	Sportsground, playground

Miscellaneous sites





	Artesian well
	Historic site, ruins

3.4.4 Offshore Structures and Markers

Structures

	Drilling platform
	Production platform
	Injection platform
	Offshore loading terminal (SBM etc.)





Buoys etc.

	Lightship
	Navigation light
	Navigation beacon (no light)
	Buoy with light
	Buoy without light



Metocean buoys

The symbols used below comply with IALA maritime buoyage system which has been adopted by IHD for their charting specifications.



The cross on top of buoy is to indicate that the buoy is not primarily used to assist navigation but to indicate special features.

	Metocean buoy without light
	Metocean buoy with light
	Metocean buoy with light and data transmission
	Metocean buoy - others
	Metocean station (on fixed structure)

Obstacles















	Wreck, visible
	Wreck, submerged
	Wreck (minimum depth)

3.4.5 Informative Symbols







	Navigable limit on a river for: (S) = seagoing vessel, (L) = launch, (C) = canoe: minimum depth of river in dry season two metres
	Tidal range

3.5 Natural Features

3.5.1 Linear Features

Coastlines	
	Coastline
	High-water line
	Low-water line
	Shore line of lake
Rivers	
	River (single line), with direction of flow
	River banks, with direction of flow
	Braided stream
	Drainage pattern, wadi
General feature boundaries	
	Vegetation boundary
	Soil type/characteristic boundary (marsh, dunes)
	Limit of reefs
Miscellaneous	
	Fill, dyke, embankment
	Cut
	Valley with steep walls, canyon

3.5.2 Point Features



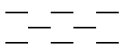
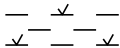
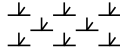
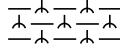

Water	
	Spring
	Waterfall (with height)
	Rapids
	River disappears
	River reappears
Terrestrial	
	Rock
	Volcano, active, inactive

3.5.3 Area Features



Swamps

	Swamps, marshy country
	Tidal swamp
	Swamp with palms
	Mangrove swamp



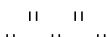

Woodland

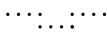
	Wood, forest, trees
	Wood with high trees
	Wood with low trees, shrub
	Palm trees (palm grove, oasis)

Open country

	Natural grassland (savannah, pampas, llanos, alang-alang)
	Dunes
	Drift sand

Miscellaneous lake and coastal features

	Lake with beach
	Salt-water lake
	Salt flat
	Sandbank or mud-flats
	Reef (cor = coral, alg = algae)

3.5.4 Environmental Maps

Symbols and colours for environmental maps are not proposed. These maps are generally produced by specialized contractors. The guiding principle for these maps is to represent the environmental features in such a way that the objective of the map is met.

3.6 Elevation Contours

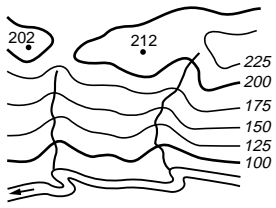

3.7 Bathymetric Contours

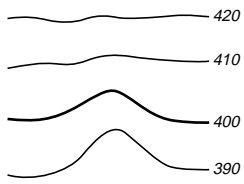











4.0 GEOLOGY





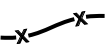
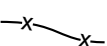
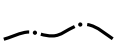

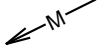

4.1 Photogeology

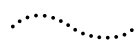
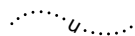
Morphological and geological features inferred from photogeological evidence may be coloured in brown and purple respectively if data of different origin occur on the same map. Alternatively, the Greek letter ϕ may be placed near a particular symbol, to indicate the photogeological nature of the data. Reliability of the observations may be indicated by drawing the symbols given below in an interrupted fashion in case of conjectural data. To further emphasize this conjectural character, query marks may be placed in the resulting interruptions.

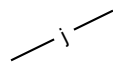
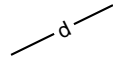
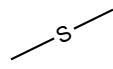

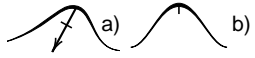
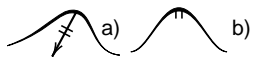
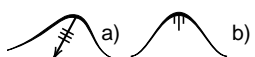

4.1.1 Morphological Features

	Outer edge of terrace or declivity (teeth away from edge) The letters "a" or "e" may be used to distinguish accumulation or erosion terraces.
	Landslide
	Scree slope
	Karst solution hollows (sink-holes, uvalas, poljes, dolines)
	Volcanic cone
	Generally depressed area, negative aspect relative to surroundings
	Generally elevated area, positive aspect relative to surroundings
	Abrupt change of relief, e.g. foot of hills
	Major divide or crestline
	Minor divide or crestline
	Linear feature of unknown origin
	Wind direction
	Direction of morphological dip (dip of surface, plain, terrace etc.) Use symbols from 4.1.2, combined with letter "M", for added precision, if desired.

4.1.2 Geological Features (see also 4.7 Structural Geology)

	Lithostratigraphical boundary	
	Unconformity; the use of heavier dots for unconformities is optional	
	Edge of stratum, whether expressed as scarp, scarplet or otherwise deduced	
	Joint	
	Dike	
	Strike line (general symbol)	
	Horizontal bedding	
	Subhorizontal (< 2°) bedding (slight southerly dip)	
	Outcropping layer with dip slope in general The arrow should be extended over the full length of the visible dip slope.	
	Gentle dip slope (2°-5°)	
	Moderate dip slope (6°-20°)	Symbols without arrows: b) may be used when space problems prohibit the arrow symbology of a)
	Steep dip slope (>20°)	
	Vertical bed	

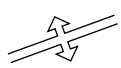
Regional or large-scale features may be distinguished from local or minor features by using open vs. closed symbology, e.g.:

	Direction of dip, regional
	Direction of dip, local
	Axis of major regional high, culmination, geanticline
	Axis of high, anticline

4.2 Lithology

4.2.1 Order of Description

1. Main lithotype
2. Secondary lithotype(s), important admixture or qualifier
3. Texture and composition
4. Porosity and permeability
5. Colour
6. Accessory minerals
7. Fossils
8. Stratification
9. Post-depositional features
10. Hydrocarbon shows (see 2.3)

Examples

Main lithotype	Secondary lithotype	Texture and composition	Porosity and permeability	Colour	Accessory minerals	Fossils	Stratification	Post-depositional features	Hydrocarbon indications
Limestone Lime wackestone	argillaceous	pelletoidal	Archie type I/II A+B	buff	pyritic	foraminiferal	well bedded	cemented, slightly fractured	some dead oil stain
Lst, Wkst*	arg*	peld*	I/II A+B*	buf*	pyr*	foram*	<u>bd</u> *	cmt (frac)*	(dead oil)
Sandstone	calcareous	fine-coarse grained, poorly sorted, angular	tight to slightly permeable	brown-green	glauconitic	pelecypods	cross-bedded	jointed	
Sst*	calc*	f-crs (srt) ang*	tight-(perm)*	brn-grn*	glc*	Pelcp*	xbd*	jt*	

*abbreviation

4.2.2 Siliciclastics

General

The siliciclastic rocks comprise those in which detrital silica compounds such as quartz, feldspar or clay minerals are dominant.

Ideally, the rock name consists of two parts:

1. compositional prefix, and
2. major size class.

Example : quartz-sandstone

4.2.2.1 Framework Composition (particles >20 μ)

These symbols are optional, and are added to the main lithological symbol.

Symbol	Name of component	Abbreviation
Q	Quartz	Qz
F	Feldspar	Fld
L	Lithoclast, rock fragment	Lcl
L ^{Lst} L _{Clst}	The composition of the lithoclasts can be indicated by the abbreviations to the right of the column, e.g. limestone and claystone.	
(L)	Minor amounts can be indicated by putting the symbol between brackets.	

4.2.2.2 Siliciclastic Lithotypes

	Symbol	Name brackets = adjective	Abbreviation	Admixture adjective	Streaks, lenses
422201		Breccia	Brc		
422202		Gravel	Grv		
422203		Conglomerate	Cgl		
422204		Sand	S		
		(very sandy)	s		
		(slightly sandy)	(s)		
		Sandstone	Sst		
422205		Silt	Slt		
		Siltstone	Sltst		
422206		Clay	Cl		
422207		Claystone	Clst		
422208		Shale	Sh		
		(argillaceous)	arg		
422208		Diamictite, tillite	Tilt		
422209		Greywacke	Gwke		
422210		Arkose (see also 4.3.1.10)	Ark		

Examples : Combined siliciclastic symbols

	Silty clay with sand streaks	Cl, slt + S Strk
	Lithoclastic and slightly feldspathic sand with tuff streaks	S, lcl, (fld) + Tf Strk

4.2.3 Carbonates

4.2.3.1 Carbonate Classification

Carbonate Textural Classification (Dunham, 1962, slightly modified)

Depositional (depositional texture recognizable)					Indeter- minate	Diagenetic (depositional texture not recognizable)	
Original components were bound together	Original components not bound together during deposition					Recrystallized texture rex*	
	Lacks mud and is grain-supported	Contains mud (clay and fine silt-size carbonate)					
		Grain-supported	Mud-supported (particles >20 µm)				
			> 10% grains	< 10% grains			
					fine <10 µm)	coarse >10 µm)	
Bdst* B**	Grst* G**	Pkst* P**	Wkst* W**	Mdst* M**	aph* A**	xln* X**	suc* S**
Lime Boundstone	Lime Grainstone	Lime Packstone	Lime Wackestone	Lime Mudstone	aphanitic Lime Mudstone	crystalline	sucrosic

* abbreviation ** code for lithological columns

The mineralogy can be denoted by L for lime and Dol for dolomite (e.g. L Bdst or Dol Mdst). Dolomitized limestones still showing relict textures are better described as such. Therefore it is recommended to describe a dolomitized ooidal lime grainstone as a dolomite with ooidal relict texture rather than as an ooidal dolomite grainstone.

Classification of Reef Limestones (Embry and Klovan, 1971)

Biological			Depositional	
Encrusting binding organisms	Organisms acted as baffle	Rigid organisms dominant	10% grains > 2mm	
			grain-supported	mud-supported
Bindstone	Bafflestone	Framestone	Rudstone	Floatstone

Carbonate Classification in Lithological Columns

In lithological columns the code for texture-type is combined with the symbols for the main lithology:

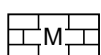

Lime mudstone



Sucrosic dolomite

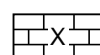

Recrystallized limestone

4.2.3.2 Carbonate Lithotypes

	Symbol	Name brackets = adjective	Abbreviation	Admixture adjective	Streaks, lenses
423201		Limestone (calcareous)	Lst calc		
423202		Limestone, dolomitic	Lst, dol		
423203		Dolomite (dolomitic)	Dol dol		
423204		Dolomite-Limestone (mixture approximately equal or not determined)	Dol-Lst		
423205		Dolomite, calcareous	Dol, calc		
423206		Chalk	Chk		
423207		Unconsolidated lime mud	L mud, uncons		

Examples : Mixtures of carbonate rock types are shown by combined symbols.



Chalky dolomite

Dol, chk



Chalky lime wackestone

Wkst, chk











4.2.4 Mixed Siliciclastics-Carbonates

General



In general, mixed lithologies can be depicted by combination of the appropriate symbols for main lithology and admixture. However, for practical reasons, the most common mixtures between siliciclastics and carbonates are treated here as a separate class.

The siliciclastic-carbonate mixture of this class must be homogeneous and the two main components must be present in approximately equal amounts. If these requirements are not met, combinations of separate symbols are to be used.

Lithotypes













	Symbol	Name brackets = adjective	Abbreviation	Admixture adjective	Streaks, lenses
42401		Marl	Mrl		
42402		Argillaceous limestone (Marlstone)	Lst, arg		
42403			Mrlst		
42404		Sandy limestone	Lst, s		

Examples : Combined symbols with other lithologies

	Calcareous shale with marl streaks	Sh, calc + Mrl Strk
	Very sandy marl	Mrl, s

4.2.5 Evaporites

Lithotypes

	Symbol	Name	Abbreviation	Admixture adjective	Streaks, lenses
42501		Gypsum	Gyp		
42502		Anhydrite	Anhd		
42503		Salt in general			
		Halite, rock salt s.s.			
42504		Potassium and magnesium salts in general			

Important potassium and magnesium salts

Name	Formula	Abbreviation
Sylvinite	KCl.NaCl	Sv
Kainite	KCl.MgSO ₄ .3H ₂ O	Ka
Polyhalite	K ₂ Ca ₂ Mg(SO ₄) ₄ .2H ₂ O	Ph
Kieserite	MgSO ₄ .H ₂ O	Ki
Carnallite	KCl.MgCl ₂ .6H ₂ O	Cn
Bischofite	MgCl ₂ .6H ₂ O	Bi
Tachydrite	CaCl ₂ .2MgCl ₂ .12H ₂ O	Ty

Example :

The mineralogical composition of the potassium-magnesium salts is indicated by adding the appropriate abbreviations to the right of the column.

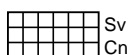

KMg salts composed of sylvinite and carnallite

4.2.6 Organic-rich Rocks

Lithotypes

	Symbol	Name brackets = adjective	Abbreviation	Admixture adjective	Streaks, lenses
42601		Peat			
42602		Coal, general (carbonaceous)	C c		

Composition

Composition and gross rank of coals can be shown by adding an abbreviation/code to the right of the symbol:

Lignite, brown coal	Lig
Hard coal	C, hd
Bituminous coal	C, bit
Anthracite	Anthr
Humic coal	C, humic
Sapropelic coal (cannel coal, boghead)	C, sapropel

If more precise coal rank data pertaining to some standard system are available, they can be shown by adding abbreviation plus value: I = International System; F = Fixed Carbon; B = BTU/lb; C = Kcal/kg.

Example

	C, hd (I.7)	Hard coal, Class 7 of International System	C, hd, I.7
--	----------------	---	------------

Miscellaneous











	Coal conglomerate	CCgl	
	Root bed		
	Plant remains (see also 4.3.5.2)	Plt Rem	
42603	(bituminous)	bit	

Examples : Combined symbols with other lithologies



	Slightly sandy shale with coal streaks	Sh, (s) + C Strk
	Bituminous argillaceous limestone	Lst, arg, bit
	Bituminous shale, oil shale	Sh, bit

4.2.7 Miscellaneous Sediments

Lithotypes

	Symbol	Name brackets = adjective	Abbreviation	Admixture adjective	Streaks, lenses
42701		Chert	Cht		
42702		Silicilyte, silicilith	Sct		
		Phosphate	Phos		
		Ironstone (ferruginous)	Fest fe		
42703		Glauconite	Glc		

Examples : Combined symbols with other lithologies

	Glauconitic and ferruginous sandstone	Sst, glc, fe
	Cherty chalk	Chk, cht

4.2.8 Igneous Rocks

4.2.8.1 Intrusive (Plutonic) Rocks

Classification and nomenclature according to modal mineral content (volume %), highly generalized after Streckeisen (1976).

For classification, the following minerals and mineral groups are used:

- Q Quartz
- A Alkali feldspars
- P Plagioclase
- F Feldspathoids or foids
- M Mafic and related minerals

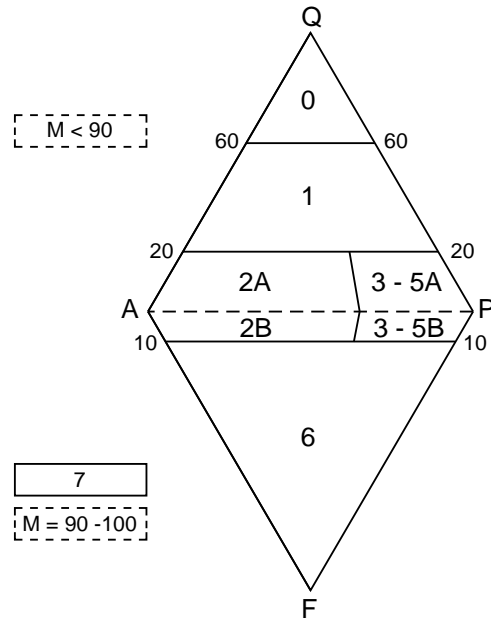

	Symbol	Abbreviation	Field in figure
428101	$\begin{array}{ c } \hline + + + \\ \hline + + \\ \hline \end{array}$	Intrusive (plutonic) rocks, general	Plut, In
	$\begin{array}{ c } \hline + + + \\ \hline + Q + \\ \hline \end{array}$	Granitoids and related rocks	1
	$\begin{array}{ c } \hline + + + \\ \hline + Q + \\ \hline \end{array}$ Gr	Granite	1
	$\begin{array}{ c } \hline + + + \\ \hline + Q + \\ \hline \end{array}$ Grdr	Granodiorite	1
	$\begin{array}{ c } \hline + + + \\ \hline + A + \\ \hline \end{array}$	Syenitoids	2
	$\begin{array}{ c } \hline + + + \\ \hline + A + \\ \hline \end{array}$ Sy	Syenite	2
	$\begin{array}{ c } \hline + + + \\ \hline + P + \\ \hline \end{array}$	Dioritoids, gabbroids, anorthosites	3-5
	$\begin{array}{ c } \hline + + + \\ \hline + P + \\ \hline \end{array}$ Dr	Diorite	3-5
	$\begin{array}{ c } \hline + + + \\ \hline + P + \\ \hline \end{array}$ Gb	Gabbro	3-5
	$\begin{array}{ c } \hline + + + \\ \hline + P + \\ \hline \end{array}$ Ao	Anorthosite	3-5
	$\begin{array}{ c } \hline + + + \\ \hline + F + \\ \hline \end{array}$	Alkaline rocks	2-5B, 6

Symbol		Abbreviation	Field in figure
	Ultramafic rocks	Umaf	7
	Peridotites	Pdt	7

4.2.8.2 Dykes, Sills

	Dyke, sill	Dy
	Dolerite	Do
	Diabase	Db

4.2.8.3 Extrusive (Volcanic) Rocks









428301		Extrusive rocks, general	Vo, Ex
		Extrusives without feldspathoids	
		Rhyolite	Rl
		Porphyry	Po
		Andesite	An
		Basalt	Ba
		Dolerite	Do
		Extrusives with feldspathoids	

			Admixture	Streaks, lenses
	Pyroclastic rocks	PyrcI		
428302		Tuff		
		Welded tuff, ignimbrite		
		Agglomerate, volcanic breccia		

4.2.8.4 Ophiolites

428401		Ophiolites
--------	--	------------

4.2.9 Metamorphic Rocks

	Symbol		Abbreviation
42901		Metamorphic rocks, general	Metam
		Slate Phyllite	Sl Phy
		Quartzite	Qzt
		Marble	Marb
42902		Schist	Sch
	 Mic	Mica-schist	Sch, mic
		Gneiss	Gns
	 Migm	Migmatite	Migm
	 Am	Amphibolite	Am

4.2.10 Lithological Colour Symbols

Lithological colour symbols are given for some important rock types as alternatives to black and white lithological symbols.

	olive drab	Gravel, conglomerate, breccia
	yellow	Sand, sandstone
	pale green 1	Silt, siltstone
	grey 50	Clay, claystone, shale
	brown	Diamictite
	lawn green	Marl(stone), calcareous clay (/shale)
	middle cyan	Limestone, chalk
	middle blue	Dolomite
	light magenta	Gypsum, anhydrite
	aquamarine 1	Rock salt
	black	Coal
	deep pink	Plutonic rocks
	orange	Volcanic rocks
	aquamarine 3	Ophiolites
	salmon	Metamorphic rocks

Sub-types may be shown by combination of the respective black and white symbols with the colour of the dominant components, e.g.:

	Calcareous sand
	Sandy limestone

For colours see Appendix 4

4.3 Rock Description

4.3.1 Texture and Composition

4.3.1.1. Grain Size (Wentworth's (1922) scale, slightly modified)

mm	μ	ϕ ²⁾	visual	Nomenclature		Abbreviation
256		-8		Rudite	Boulder	Bld
64		-6			Cobble	Cbl
4		-2	●		Pebble	Pbl
2		-1	●		Granule	Gran
1		0	•	Arenite	very coarse	<u>crs</u>
1/2	500	1	.		coarse	crs
1/4	250	2			medium	m
1/8	125	3			fine	f
1/16	63	4			very fine	<u>f</u>
1/50	20	5.65		Lutite	Silt ¹⁾	Slt
					Pelite ¹⁾	Pel

Note : 1) For practical reasons Wentworth's (1922) division of the Lutites into Clay and Silt at the 4μ (1/256mm) boundary has been replaced by the above subdivision into Pelite and Silt at the 20μ boundary.

2) $\phi = -\text{Log}_2$ diameter in mm

4.3.1.2 Sorting

	Abbreviation
Very poorly sorted; unsorted	((srt))
Poorly sorted	(srt)
Poorly to moderately well sorted	(srt) - srt
Moderately well sorted	srt
Well sorted	<u>srt</u>
Very well sorted	<u><u>srt</u></u>
Unimodally sorted	unimod srt
Bimodally sorted	bimod srt

4.3.1.3 Roundness (roundness refers to modal size class)

		Abbreviation
Very angular	< 0.1	<u>ang</u>
Angular	0.2	ang
Subangular	0.3	(ang)
Subrounded	0.4	(rnd)
Rounded	0.6	rnd
Well rounded	> 0.85	<u>rnd</u>

4.3.1.4 Sphericity (sphericity refers to modal size class)

Very elongated	< 0.5	<u>elong</u>
Elongated	0.5 - 0.6	elong
Slightly elongated	0.6 - 0.7	(elong)
Slightly spherical	0.7 - 0.8	(sph)
Spherical	0.8 - 0.9	sph
Very spherical	> 0.9	<u>sph</u>

4.3.1.5 Compaction

Not compacted		not cmp
Slightly compacted		(cmp)
Compacted		cmp
Strongly compacted		<u>cmp</u>
Friable		fri
Indurated		ind
Hard		hd

4.3.1.6 Non-skeletal Particles

Non-skeletal particles are primarily classified according to degree of rounding and aggregation:

	Symbol		Abbreviation
431601	◇	Angular fragment, lithoclast	Lcl
	◈	Lithoclasts, aggregated	Lcl, aggr
	○	Rounded particles (not determined further)	Psoo
	⊙	Rounded aggregated particles (grapestone)	Gpst

4.3.1.7 Non-skeletal Particle Texture and Size

Particle texture and size are indicated by symbols which are combined with the classification according to degree of rounding and aggregation (see above):

431701	◇	1/16 - 4 mm	} Muddy internal texture
431702	◈	> 4 mm	
431703	⊙	1/16 - 4 mm	
431704	⊙	> 4 mm	
431705	◇	1/16 - 4 mm	} Composite internal texture
431706	◈	> 4 mm	
431707	⊙	1/16 - 4 mm	
431708	⊙	> 4 mm	

4.3.1.8 Pellets and Coated Grains

431801	∞	Faecal pellet, coprolite	Pel, fae
431802	ϕ	Micropelletoid (<1/16 mm)	Micrpeld
431803	⊙	Pelletoid (1/16 - 2mm)	Peld
431804	⊖	Superficial ooid (single layer)	Oo, spf
Single-layer coating of particles is indicated by adding horizontal bars to the appropriate symbol.			
431805	⊙	Ooid (1/16 - 2 mm)	Oo
431806	⊙	Pisoid (> 2 mm)	Piso
431807	⊙	Onkoid (1/16 mm - 2 mm)	Onk
431808	⊙	Onkoid (> 2 mm)	Onkd

4.3.1.9 Skeletal Particles

Skeletal particles have the same basic symbol as used for fossil content (4.3.5), supplemented with signs indicating fragmentation, rounding and/or coating:

	Symbol		Abbreviation
431901		Whole fossils, unspecified	Foss
431902		Bioclasts (unspecified broken fossils), angular	Bcl, ang
431903		Bioclasts (unspecified broken fossils), rounded	Bcl, rnd
431904		Larger foraminifera, coated	
431905		Pelagic foraminifera, broken	

Examples : Combined carbonate symbols

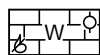

Pelletoidal and bioclastic lime wackstone

Wkst, peld, bcl

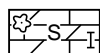

Chalky and onkoidal, dolomitic limestone

Lst, dol, chk, onk

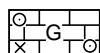

Oolitic partly recrystallized lime grainstone

Grst, oo, part rex

4.3.1.10 Compositional Siliciclastics Classification (modified after Pettijohn, Potter & Siever, 1987)

Arenite (< 15% matrix)

Quartz arenite

Sub-arkose

Arkosic arenite

Sub-litharenite

Litharenite

Arkose

Ark

Lithic arkose

Wacke (15% < matrix < 75%)

Feldspathic wacke











Lithic wacke

Claystone (matrix > 75 %)







Clst

4.3.2 Porosity and Permeability

4.3.2.1 Fabric Selective Porosity

	Symbol		Abbreviation
432101		Intergranular (particle size > 20μ)	intergran Por
432102		Fine interparticle (particle size < 20μ)	f interpart Por
432103		Intercrystalline	interxln Por
432104		Intragranular	Intragran Por
432105		Intraskelatal	intraskel Por
432106		Intracrystalline	intraxln Por
432107		Mouldic	mld Por
432108		Fenestral	fnstr Por
432109		Shelter	Shelt Por
432110		Framework	Frmwk Por

4.3.2.2 Non-fabric Selective Porosity

432201		Fracture	Frac Por
432202		Stylolitic	stltc Por
432203		Replacement	repl Por
432204		Solution	sol Por
432205		Vuggy, vugular	vug, vug Por
432206		Channel	chnl Por
432207		Cavernous (person-sized pore)	cav, cav Por

4.3.2.3 Relative Timing of Porosity Generation

P }
S } added to the left
of code and symbol

Primary porosity
Secondary porosity

Example

Abbreviation

Primary, intergranular porosity P intergran Por

4.3.2.4 Porosity (qualitative by visual estimate)

Non-porous, dense, no visible porosity nonpor
Slightly (poorly) porous (por)
Fairly porous; porous por
Highly porous por

4.3.2.5 Permeability (qualitative)

Impermeable, tight imperm, tight
Slightly (poorly) permeable (perm)
Fairly permeable; permeable perm
Highly permeable perm

4.3.2.6 Archie Classification

Matrix texture plus size, frequency and degree of interconnection of vugs are used on a purely geometrical basis (Archie, 1952).

Matrix texture (at 10x magnification)

	Archie code
Compact, crystalline; often "feather-edge" appearance on breaking	I
Friable, dull, earthy or chalky appearance; particle size < 20 μ ; often exhibits capillary imbibition	II
Visibly particulate, granular or sucrosic appearance; often exhibits capillary imbibition	III
Gradational textures are quite common, e.g.: Compact interlocking to particulate	I/III
Composite textures also occur, e.g.: Chalky matrix with sucrosic patches	II+III

4.3.2.7 Archie Porosity Types

	Symbol		Code
		No visible vugs	A
		Vugs < 0.125 mm	B
		Vugs 0.125 - 2 mm	C
		Vugs > 2 mm	D
432701	/	Vugs, disconnected < 10%	d
432702	/	Vugs, disconnected > 10%	d
432703	/—	Vugs, connected < 10%	c
432704	/—	Vugs, connected > 10%	c
		Matrix porosity < 10%	
		Matrix porosity > 10%	

Examples : combined Archie symbols

Suppose 60% of the rock consists of type II in continuous phase:
 Of this type 3% by volume consists of disconnected B-sized vugs.
 40% of the rocks consists of type III very fine grained in patches:
 Of this type 5% by volume consists of interconnected C-sized vugs.

Then the Archie formula reads: 60 II B_{3d} + 40 III f_{C5c}

Suppose 70% of the rock consists of type I to II which forms the matrix with no visible porosity, and 30% of the rock consists of sucrosic streaks with 2% disconnected size A vugs and 1% interconnected size D vugs.

Then the Archie formula reads: 70 I/II + 30 III A_{2d}D_{1c}

4.3.3 Colour Description

General

Colours are described by means of the Rock Colour Chart based on the Munsell System (Goddard, Trask *et al.*, 1963).

If possible, colours should be denoted by code, e.g. 5G 5/2, with names optionally added, e.g. greyish green. When using informal abbreviations, weak and modifying colours (-ish) are placed between brackets. Vivid or strong colours are underlined.

4.3.3.1 Colours

	Abbreviation		Abbreviation
black	blk	orange	orng
blue	blu	pink	pk
brown	brn	purple	pu
buff	buf	red	red
green	gn	translucent	transl
grey	gy	white	wh
olive	olv	yellow	yel

4.3.3.2 Modifying Adjectives

	Abbreviation
dark	dk
light	lt
moderate, medium	mod
mottled, variegated	mtl, vgt
slight, weak	(colour)
strong, vivid (emphasis)	<u>colour</u>

Examples

greenish brown	(grn) brn
vividly red	<u>red</u>

4.3.4 Accessory Minerals







































	Abbreviation		Abbreviation
Anhydrite	Anhd	Montmorillonite	Mtmo
Biotite	Biot	Muscovite	Musc
Calcite	Calc	Olivine	Olv
Dolomite	Dol	Orthoclase	Orth
Feldspar	Fld	Plagioclase	Plag
Glauconite	Glc	Pyrite	Pyr
Gypsum	Gyp	Pyroxene	Px
Hornblende	Hrnb	Quartz	Qz
Illite	Ill	Selenite	Sel
Kaolinite	Kao	Siderite	Sid
Limonite	Lmn	Sulphur	Su
Mica	Mic	Crystal	XI

4.3.5 Fossils







4.3.5.1 Fossils, General (see also 4.3.1.9)

	Symbol		Abbreviation
435101	♁	Fossils in general	Foss
	♁ _F	Fossils, fresh water	Foss, fresh
	♁ _B	Fossils, brackish water	Foss, brack
	♁ _M	Fossils, marine	Foss, mar
435102	♁ _b	Fossils, benthonic	Foss, bent
435103	♁ _p	Fossils, pelagic	Foss, pelg
	(♁)	Brackets around fossil symbol and/or abbreviation signify few or rare occurrences	
	<u>♁</u>	Underlining of symbol and/or abbreviation indicates rich occurrences	
435104	♁	Crossing out of a fossil symbol indicates broken fragments of that fossil	

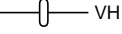

4.3.5.2 Fossils, Specific

	Symbol	Abbreviation		Symbol	Abbreviation
435201		Acritarchs	Acrt	435222	 Graptolites Grap
435202		Algae	Alg	435223	 { Lamellibranchs Pelcypods Bivalves Lbr Pelcp Biv
435203		Ammonites	Amm		
435204		Belemnites	Blm		
435205		Brachiopods	Brac	435224	 Lamellibranchs, pelagic Lbr, pelg
435206		Bryozoa	Bry	435225	 Microplankton Mpl
435207		Charophytes	Char	435226	 Molluscs Mol
435208		Chitinozoa	Chtz	435227	 Nannoplankton, calcareous Nanplk
435209		Conodonts	Con	435228	 Oligostegina (Calcispheres) Oligst, Calsph
435210		Corals	Cor	435229	 Ostracods Ost
435211		Crinoids	Crin	435230	 Plant remains Plt Rem
435212		Diatoms	Diat	435231	 Radiolaria Rad
435213		Dinoflagellates	Dinfl	435232	 Rudists Rud
435214		Echinoderms	Ech	435233	 Spicules Spic
435215		Fish remains Fish scales	Fish Rem Fish Sc	435234	 Sporomorphs Spr
435216		Foraminifera general	Foram	435235	 Stromatoporoids Strom
435217		Foraminifera, larger	Foram, lg	435236	 Tintinnids Tin
435218		Foraminifera, smaller	Foram, sm	435237	 Trilobites Tril
435219		Foraminifera, smaller, benthonic	Foram, sm, bnt	435238	 Vertebrates Vrtb
435220		Foraminifera, pelagic, planktonic	Foram, pelg/plk	435239	 Wood, silicified Wd, si
435221		Gastropods	Gast		

4.3.5.3 Ichnofossils

	Symbol		Abbreviation
435301		Trails, "wormtracks", trace fossils	
435302		Vertebrate tracks	
435303		Burrows, vertical or horizontal	Bur
435304		Churned, bioturbated	
435305		Borings and animal tubes	Bor
435306		Bored surface	Srf, bor

4.3.5.4 Organogenic Structures





435401		Algal mats, stromatolites	Alg Mat
		Algal domes, domal stromatolites	Alg Dom
435402		Plant root tubes, rootlets	Plt Rt

4.3.6 Stratification and Sedimentary Structures

4.3.6.1 Bed Thickness

		Abbreviation		Abbreviation
Millimetre bedded	< 1 cm	mm - bd	Thin bedded	tn - bd
Centimetre bedded	1 - 10 cm	cm - bd	Thick bedded	tk - bd
Decimetre bedded	10 - 100 cm	dm - bd	Variable bedded	vr - bd
Metre bedded	> 100 cm	m - bd		





4.3.6.2 Bedding Appearance

Symbol		Abbreviation
	Massive, no apparent bedding	unbd, mass
	Slightly (poorly) bedded	(bd)
	Fairly well bedded; bedded in general	bd
	Well bedded	<u>bd</u>
	Very well bedded	<u><u>bd</u></u>

Example

Massive to slightly bedded mass - (bd)

4.3.6.3 Character of Base of Bed

	Abrupt or sharp, planar
	Abrupt or sharp, irregular
	Gradational
436301 	Erosional surface, erosional contact

4.3.6.4 Miscellaneous Terms

Amorphous	amor
Blocky	blky
Conchoidal	conch
Fissile	fis
Flaky	flk
Laminated (see also 4.3.6.8)	lam
Papery	pap

4.3.6.5 Large Sedimentary Features

	Symbol		Abbreviation
436501		Wedge-shaped layer, tongue	Wdg
436502		Lenticular layer, lens	Len
436503		Unit with concave bottom and flat top (scour-and-fill, channel, wash-out)	
436504		As above, with horizontal fill	
436505		As above, but with foreset infill	
436506		Unit with convex top and flat bottom (add bedding attitude as above)	
436507		Olistolith, slide, rockfall	Olisth
436508		Olistostrome, mass flow	Olistr
436509		Bioherm	
436510		Biostrome	
436511		Reef	

Note : The lithological composition of the sedimentary unit can be shown by the appropriate symbol :

Example

	Limestone olistolith	Lst Olisth
--	----------------------	------------







4.3.6.6 Cross-bedding

436601		Cross-bedding (non-directional)	xbd
		Trough cross-bedding	xbd-tr
		Festoon cross-bedding	xbd-f
		Tabular cross-bedding	xbd-tb
		Planar cross-bedding	xbd-p
		Ripple-drift, climbing ripples	xbd-r
436602		Cross-bedding, chevron or herringbone type	xbd-c
436603		Hummocky cross-stratification	xbd-hm
436604		Swaley cross-stratification	xbd-s
		Cross-bedding, with angle indicated	xbd-A10
436605		Cross-bedding, directional (azimuth N80°E)	xbd-N80E



Examples : Bedding type and thickness can be combined as follows

	cm	Well bedded, centimetre thickness	cm - <u>bd</u>
	Pdm	Planar cross-bedding, 1-10 cm thick beds, directed N25°E	cm - xbd - P - N25E







4.3.6.7 Ripplemarks on Bedding Planes

	Symbol		Abbreviation
436701		Adhesion ripples	adh-Rpl
436702		Asymmetrical ripples in general	asym-Rpl
		Planar, parallel ripples	plan-Rpl
436703		Symmetrical ripples	sym-Rpl
		Interference ripples, "tadpole nests"	intf-Rpl
		Lunate, barchanoid, crescentic ripples (steep sides concave)	conc-Rpl
		Linguoid, lobate ripples (steep sides convex)	conx-Rpl





4.3.6.8 Horizontal Lamination

	L	Parallel	
	L	Non-parallel	
	V	Varves	Varv

4.3.6.9 Wavy/Irregular/Lenticular Stratification

436901		Parallel wavy	
436902		Flaser	
436903		Irregular, wavy bedding	irg-bd
436904		Lenticular, linsen bedding	
436905		Streaky	
436906		Crinkled	crink-bd

4.3.6.10 Graded Beds

4361001		Graded bedding	grd-bd
4361002		Normal grading/fining upward	
4361003		Inverse grading/coarsening upward	
		Lag	











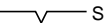
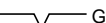

4.3.6.11 Lineations on Bedding Planes

	Symbol		Abbreviation
4361101		Parting lineation	} primary current lineation
4361102		Streaming lineation	
4361103		Shell, fossil lineation	foss-Lin
4361104		Plant fragment lineation	plt-Lin
4361105		Sand grain lineation	grain-Lin
4361106		Pebble lineation	pbl-Lin



4.3.6.12 Soft Sediment Deformation

4361201		Flame structure	
4361202		Dish (and pillar) structure	
4361203		Load casts	load-Cs
4361204		Oversteepening, overturning	
4361205		Ptygmatic fold/entherolithic bedding	
4361206		Convolute bedding	conv-bd
4361207		Slumped, contorted bedding	slump, cont-bd
4361208		Drag folds (sedimentary)	Drgfld, sed
4361209		Vein, sedimentary dyke	Vn, Dyke

4.3.6.13 Syndepositional Marks and Miscellaneous Structures





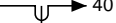



	Symbol		Abbreviation
4361301		Clay drape	
4361302		Carbonaceous drape	
4361303		Flute casts	flut-Cs
4361304		Striation casts (< 2 mm wide)	stri-Cs
		Groove casts (> 2 mm wide)	grov-Cs
4361305		Prod casts; bounce casts	prod-Cs
4361306		Raindrop imprints; gas, air or spring pits	rain-Imp
4361307		Mudcracks	Mdcrk
4361308		Syneresis cracks	
4361309		Salt moulds or hoppers	salt-Mld
4361310		Pseudo-nodules; phacoids	Psnod
4361311		Tepee structure	
4361312		Pebble imbrication	pbl-Imb
4361313		Geopetal fabric; floored cavities	

Directional features can be indicated by adding an arrow-head to the symbol and a numerical value corresponding to the direction(s):

4361314		Flute casts, directed N180°E, secondary direction N120°E	flut-Cs, N180E + (N120E)
4361315		Striation casts and prod casts, directed N25°E and N40°E resp.	stri-Cs, N25E + prod-Cs N40E
4361316			

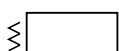
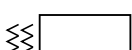
4.3.7 Post-depositional Features

4.3.7.1 Miscellaneous Post-depositional Features

Symbol		Abbreviation
	Unconsolidated, loose (e.g. sand, gravel)	uncons, lse
	Slightly consolidated, friable	(cons), fri
	Consolidated, cemented, hard (e.g. sandstone, conglomerate)	cons, cmt, hd
	Strongly cemented, highly consolidated (e.g. quartzitic sandstone)	<u>cons</u> , <u>cmt</u>
J 	Jointed (V = Vertical; H = Horizontal)	jt
	Disturbed; faulted, fractured, slickensided	flt, frac, sks
	Highly disturbed; faulted, fractured, slickensided	<u>flt</u> , <u>frac</u> , <u>sks</u>
	Weathered, leached; soil bed (drawn across lithological symbols)	weath, leach
	Red beds (can be drawn across other lithological symbols or down right-hand margin of lithological column)	Redbd
		
	Caliche (can be drawn across other lithological symbols)	

4.3.7.2 Diagenetic Structures

	Symbol		Abbreviation
437201		Boudinage; ball-and-flow structure	
437202		Pull-apart structure	
437203		Collapse, solution breccia	Bc, sol
437204		Boxwork structure, rauhwacke	Rauhw
437205		Cone-in-cone	
437206		Stromatactis	
437207		Stylolites	
437208		Horse-tailing	
437209		Birdseye structure, keystone vugs	
437210		Fenestral structure	
437211		Crystal ghosts	
437212		Fossil ghosts } dashed outline of skeletal (4.3.5) or non-skeletal particle (4.3.1.6-8) Ooid ghosts } denotes ghost structure	
437213			

4.3.7.3 Nodules/Concretions

	Symbol		Abbreviation
437301		Concretions, nodules, geodes in general	Conc, Nod
437302		Calcareous concretions	calc-Conc
437303		Soil pisoids	
437304		Siliceous concretions	si-Conc
437305		Anhydrite concretions	anhd-Conc
437306		Anhydrite concretions compressed ("chicken-wire" type)	
		Phosphatic concretions or nodules	phos-Conc
		Siderite concretions or nodules	sid-Conc
		Ferruginous concretions or nodules	fe-Conc

4.4 Stratigraphy

4.4.1 Lithostratigraphy

4.4.1.1 Lithostratigraphical Terminology

(For further details see Salvador, 1994)

	Abbreviation		Abbreviation
Supergroup	Supgp	Lentil, lens	Len
Group	Gp	Complex	Cx
Formation	Fm	Upper, upper	U, u
Member	Mbr	Middle, middle	M, m
Bed, layer	Bd, Lyr	Lower, lower	L, l
Tongue	Tng		

4.4.1.2 Lithostratigraphical Gaps

Unconformity	U
Disconformity	D
Hiatus	Hi

4.4.2 Biostratigraphy

4.4.2.1 Zonal Terminology

The name of a (bio)zone (subzone or zonule) consists of the name(s) of the characteristic fossil(s), often in abbreviated form, combined with the appropriate term. The category of the zone (range zone or taxon-range zone, concurrent-range zone, interval zone, assemblage zone, abundance zone, lineage zone) is normally only given in the definition. A zonation comprises a number of consecutive zones.
(Further details in Salvador, 1994)

Examples :

Gonyaulacysta jurassica Assemblage Zone or *Gonyaulacysta jurassica* Zone

Chiasmolithus danicus Interval Zone or *Chiasmolithus danicus* Zone

Globigerina sellii-*Pseudohastigerina barbadoensis* Concurrent-range Zone

Globotruncanita calcarata Taxon-range Zone or *G. calcarata* Zone

Bolivinooides draco Taxon-range Zone or *Bolivinooides draco* Zone

4.4.2.2 Zones/Zonation

	Abbreviation
Micropalaeontological zone/zonation	PA-zone/zonation
Palynological zone/zonation	PY-zone/zonation
Foraminiferal zone/zonation	F-zone/zonation
Planktonic foraminifera zone/zonation	PF-zone/zonation
Benthonic foraminifera zone/zonation	BF-zone/zonation
Calcareous nannoplankton zone/zonation	N-zone/zonation
Microplankton zone/zonation	M-zone/zonation
Sporomorph zone/zonation	S-zone/zonation
Chitinozoa zone/zonation	C-zone/zonation

4.4.2.3 Quantity Symbols for Distribution Charts

NF	No fauna / flora	●	21 - 100 specimens
▪	1 specimen	■	> 100 specimens
/	2 - 5 specimens	×	Qualitative determination only
○	6 - 20 specimens		

4.4.3 Chronostratigraphy and Geochronology

The chronostratigraphical and geochronological units are homonymous.

The following Geological Data Tables (only available in the hardcopy version) show the generally accepted subdivision for the Cenozoic, Mesozoic, Palaeozoic and upper Proterozoic (ages after Harland *et al.*, 1990). The chronostratigraphical units, including regional stages not appearing on these tables, their abbreviations, ages, duration and hierarchical position are listed, differently sorted, in Appendices 1 to 3.

Abbreviations for further subdivisions are:



Chronostratigraphical units (Salvador, 1994)	Abbreviation
Upper, upper	U, u
Middle, middle	M, m
Lower, lower	L, l

Geochronological units (Salvador, 1994)





Late, late	Lt, lt
Middle/Mid, middle/mid	M, m
Early, early	Ey, ey
Million years	Ma

4.4.4 Sequence Stratigraphy





Systems Tracts

			Abbreviation
	orange	Highstand systems tract	HST
	light green	Transgressive systems tract	TST
	yellow	Lowstand systems tract	LST





Deep Water Fan System

	middle yellow	Deep water fan system (undifferentiated)	DWF
	sienna	Leveed channel complex	LCC
	dark orange	Debris flows/slumps	DF
	burlywood	Basin floor fan complex	BFF

Miscellaneous Depositional Elements

	green	Condensed systems tract (condensation horizons)	CST
	grey	Incised valley fill	IVF
	deep sky-blue 2	Forced regressive shoreface wedge	FRW
	hot pink	Lowstand wedge	LW

Surfaces

	red	Sequence boundary	SB
	green	Maximum flooding surface	MFS
	cyan	Transgressive/flooding surfaces	TS/FS
	blue	Transgressive surface of erosion (ravinement surface)	TSE
	dark violet	Regressive surface of erosion (sharp-based shoreface erosion surface)	RSE

For colours see Appendix 4

Accessory Elements

	Abbreviation
Parasequence/parasequence set	P/PS
Prograding (forestepping) parasequence set	PPS
Aggrading parasequence set	APS
Retrograding (backstepping) parasequence set	RPS

4.4.5 Stratigraphical Boundaries on Maps

4.4.5.1 General

	Certain	Uncertain	Section
Stratigraphical boundary alternative			
Disconformity, hiatus alternative			
Angular unconformity (truncation) alternative			

4.4.5.2 Layer Maps

Erosional lower edge (outcrop; subcrop see above)			
Erosional upper edge (outcrop and subcrop)			
Depositional lower edge (onlap)			
Depositional upper edge (onlap)			
Wedge-out edge			

4.4.6 Gaps and Unknown Formations

4.4.6.1 Gaps on Columnar Sections and Stratigraphical Tables

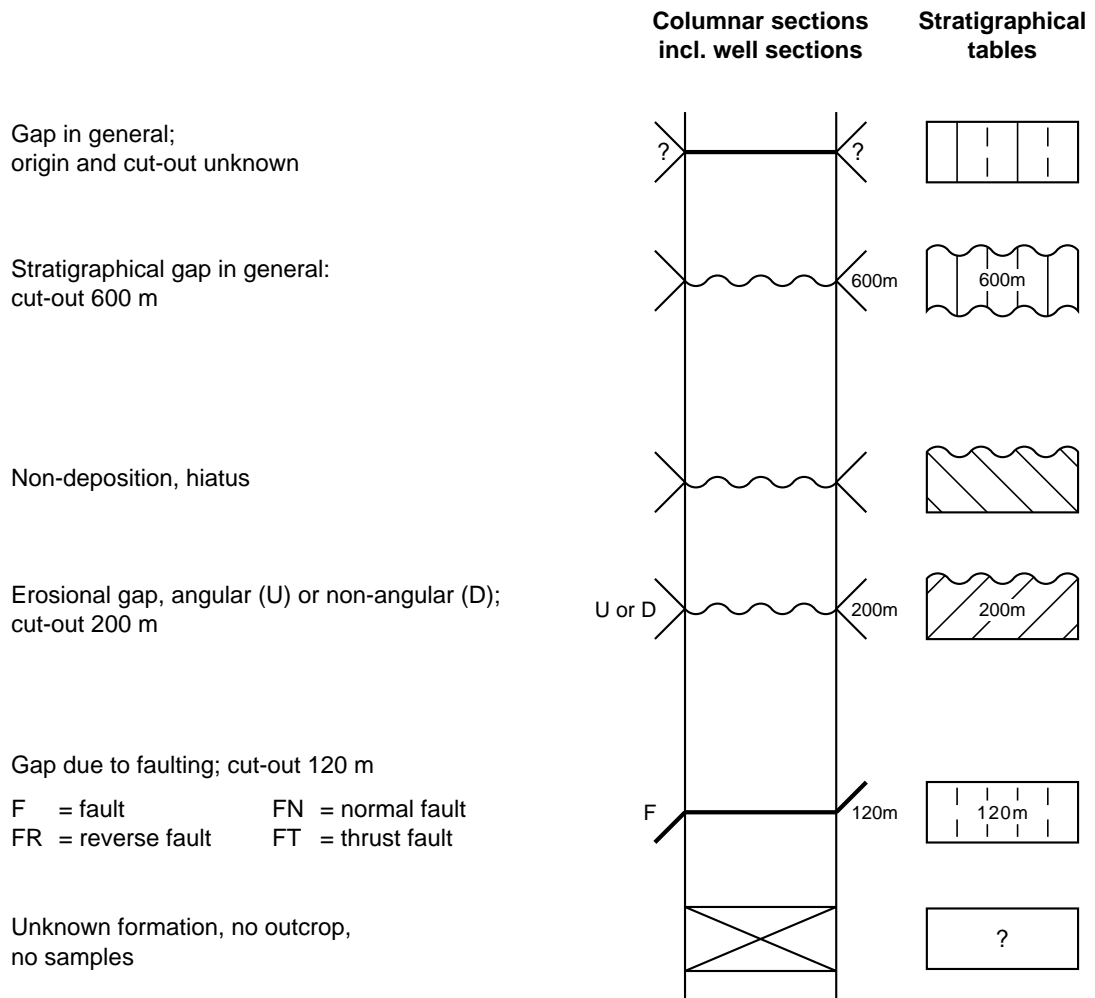

Example

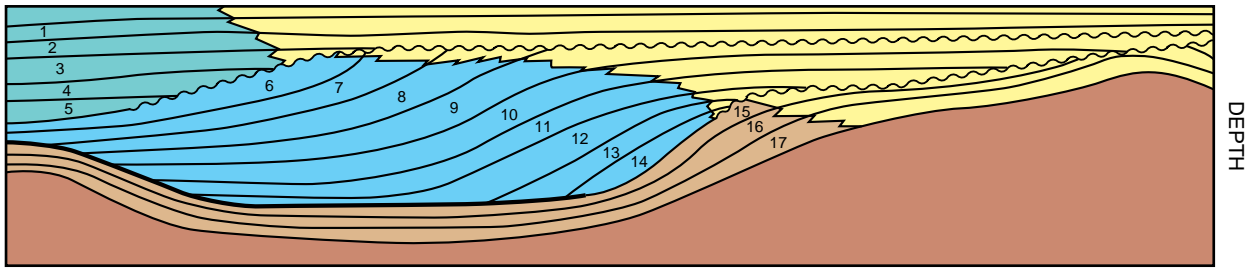

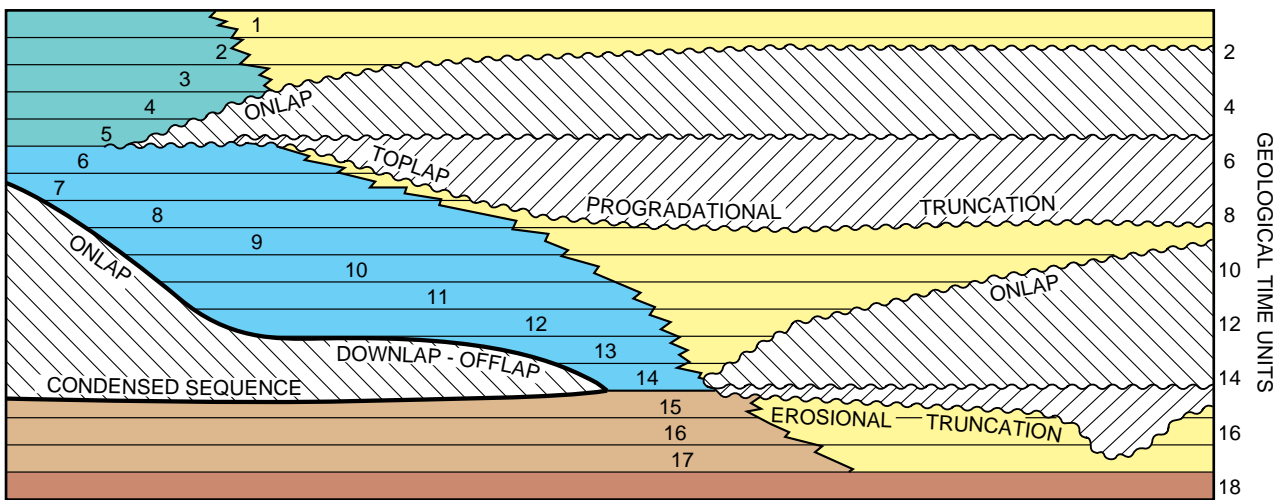

Well and outcrop calibration of the seismic depositional unit establishes lithofacies distribution. Biostratigraphy calibrates time lines and environments of deposition.



Time/rock synopsis provides the summary.

4.4.6.2 Gaps on Layer Maps

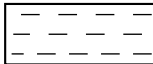
	Outcrop	Subcrop
Unit incomplete at top due to erosion		
Unit incomplete at base due to non-deposition		
Unit incomplete due to intra-formational erosion and/or non-deposition		

Examples

- a) **Layer map and explanatory section** of formation F (with members a + b) showing how the application of Sections 4.4.5 and 4.4.6 enables a maximum of detail to be plotted and interpreted.

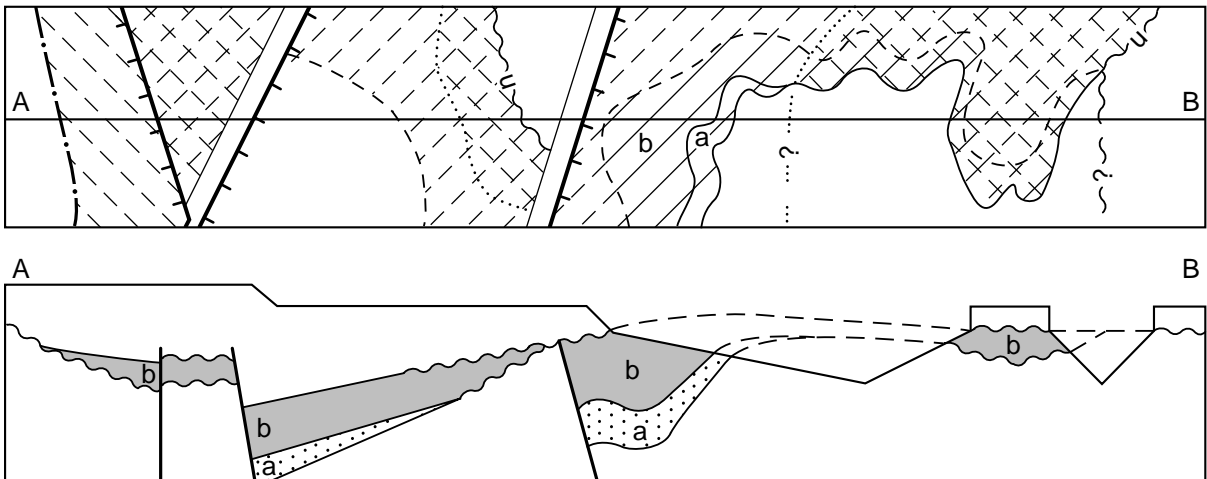

b) An alternative scheme, which minimizes areas of shading and hence permits additional information (e.g. shows) to be plotted, is the **annotated isopach map**.

Annotated isopach maps supplement the information about thickness with information on the vertical relations of the mapped stratigraphical unit.

The following symbols are added to the contour value:

- 1) N for contours where the boundaries of the mapped unit are conformable at top and bottom.
- 2) S for contours of the un-reconstructed thickness of the unit at outcrop.
- 3) Abbreviated name of overlying unit/abbreviated name of mapped unit for contours where it is truncated by the overlying unit.
- 4) Abbreviated name of mapped unit/abbreviated name of underlying unit indicating onlap.

The following lines are distinguished:

- 1) Dotted line shows where surface outcrop of the mapped unit dips beneath cover.
- 2) Dashed line shows where mapped unit onlaps/overlaps an underlying unit.
- 3) Crinkled line shows the line of truncation of the top of the mapped unit.

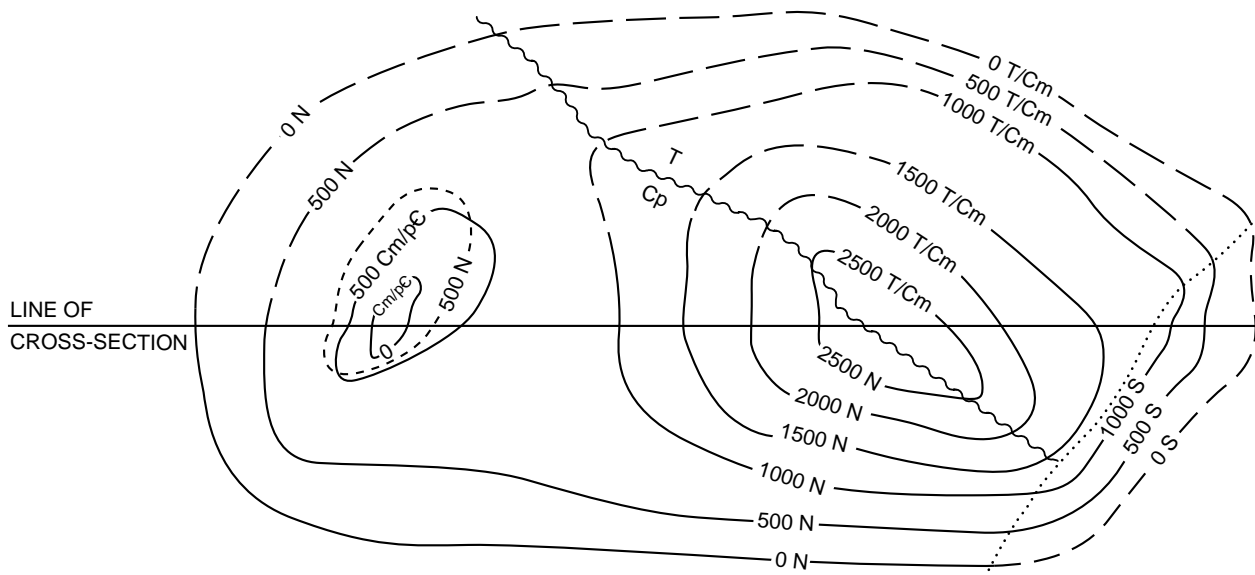
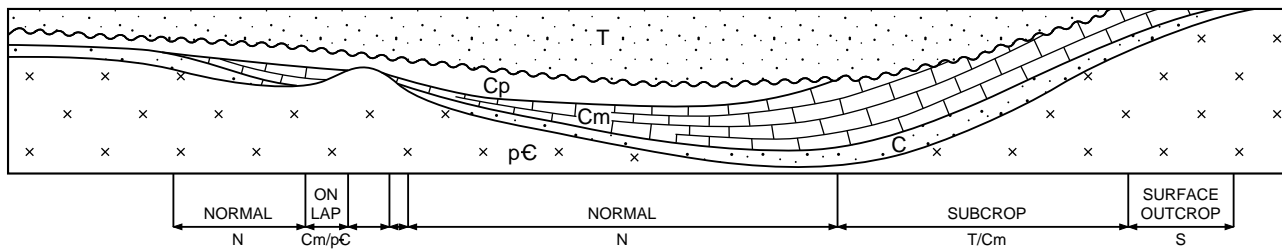

Isopach map of Cm formation

Legend

- N Normal formation boundaries, layer in normal stratigraphical succession
- T/Cm Abnormal formation contact at top of layer indicating truncated subcrop
- Cm/p€ Abnormal formation contact at bottom of layer indicating onlap
- S Surface outcrop, layer truncated by erosion

4.5 Depositional Environments

4.5.1 Biostratigraphical Charts

4.5.1.1 Abbreviations

The following abbreviations have proven useful for palaeoenvironment interpretations based on microfaunal and microfloral analysis.

Continental	CONT	Holomarine, inner neritic	HIN
Coastal plain	CP	Holomarine, middle neritic	HMN
Upper coastal plain	UCP	Holomarine, outer neritic	HON
Lower coastal plain	LCP	Bathyal	BAT
Coastal, holomarine	COL	Upper bathyal	UBAT
Coastal, fluviomarine	COF	Middle bathyal	MBAT
Fluviomarine, inner neritic	FIN	Lower bathyal	LBAT
Fluviomarine, middle neritic	FMN	Abyssal	ABL
Fluviomarine, outer neritic	FON		

4.5.1.2 Colour Coding

The following colours can be used to illustrate depositional environments distinguished in (well) sections based on microfaunal (and microfloral) analysis. Since the former permits best to distinguish environments ranging from inner neritic to lower bathyal, the colour scheme concentrates on these.

	tan	Terrestrial (continental)
	green	Coastal ("transitional marine")
	sky-blue	Neritic (shelf) - undifferentiated
	middle cyan	Inner neritic
	cyan	Middle neritic
	deep sky-blue 1	Outer neritic
	magenta	Bathyal - undifferentiated
	middle blue	Upper bathyal
	royal blue	Middle bathyal
	blue	Lower bathyal

For colours see Appendix 4

4.5.2 Maps and Sections, Colour Coding

These colour codes, primarily developed for basin modelling programs, are also suggested for maps and sections showing depositional environments. This scheme can be adapted to serve local requirements.

	tan	Terrestrial (continental)
	orange red 1	Alluvial
	orange	Coastal plain
	yellow	Upper shoreface
	aquamarine 1	Lower shoreface
	aquamarine 3	Shallow marine
	burlywood	Slope
	aquamarine 4	Deep marine
	light pink	Lagoon
	hot pink	Backreef
	royal blue	Reef
	deep sky-blue 2	Fore-reef
	turquoise	Carbonate slope

For colours see Appendix 4

4.5.3 Facies Terminology

Use of the following terminology and the hierarchy as outlined below are recommended for detailed facies analysis of cored or outcropping intervals.

4.5.3.1 Clastic Facies

Alluvial	Fan	Humid	
		Arid	
	Channel	Braided	
		Meandering	Single/multi-storey
		Anastomosed	
	Fan delta		
	Braidplain		
	Floodplain	Crevasse	
		Coal	
Lacustrine	Fluvio-lacustrine	Paleosol	
		Fines	
		Sheet	
		Mouth-bar	
		Distributary	
	Ephemeral-lacustrine	Turbidite	
		Fines	
		Sheet	
		Carbonate	
		Gypsum	
Aeolian	Dunes	Halite	
		Potash	
		Barchan	
		Ridge	
	Interdune	Toe/slipface	
		Flat	
		Dune field margins	
		Fans	
Sheet sands			

Fluvial-Aeolian

Sheet

Mouth-bar

Distributary

Fines

Carbonate

Gypsum

Halite

Potash

Interdune

Flat

Dune field margins

Fans

Sheet sands

Fluvio-Glacial

Deltaic

Wave-dominated

Offshore

Lower shoreface

Middle shoreface

Upper shoreface

Beach/foreshore

Backshore/dunes

Barrier

Lagoon

Fines

Washover

Coastal plain

River-dominated

Offshore

Prodelta

Proximal

Distal

Delta front

Mouth-bar

Upper

Lower

Distributary channel

Active

Abandoned

Interdistributary bay

Fines

Crevasse splay

Delta plain

	Tide-dominated		
	Offshore		
	Prodelta		
	Delta front		
	Tidal ridge		
	Tidal flat	Sand	
		Mixed	
		Mud	
	Tidal channel		
	Supratidal flats		
	Salt marsh		
	Mixed		
	Shelf edge		
Marginal Marine	Lagoon		
	Estuary	Fluvial	
		Bay-head delta	
		Central basin	
		Marine sand plug	
		Tidal	
	Incised valley fill		
Shallow Marine	Offshore	Outer shelf	
		Inner shelf	
		Tidal shelf ridge	
	Shoreface	Lower	Sharp-based
			Gradationally based
		Middle	
		Upper	
	Foreshore/beach		
	Barrier		
	Tidal inlet		
	Flood/ebb tidal delta		
	Tidal channel		
	Lag deposit	Transgressive	
		Regressive	

Deep Marine	Turbidite	Thick-bedded	
		Thin-bedded	
	Channel/levee complex		
	Submarine canyon		
	Fan	Basin floor	Upper
	Toe of slope	Middle	
	Slope	Lower	
	Debris flow/slump		

4.5.3.2 Carbonate Facies

















Terrestrial	Lacustrine	
	Karst	
Marginal Marine	Sabhka	
	Lagoon	
Marine	Platform	Rimmed/unrimmed
		Ramp
		Shelf
		Bank
		Basin
	Peritidal	
	Reefs/mounds	Back reef
		Reef flat
		Reef crest
		Reef front
	Fore reef	
	Slopes	Upper
		Lower
Deep Marine	Turbidite	
	Slump	
	Autochthonous	

4.6 Palaeogeographical Maps







4.6.1 Basin Scale Maps (after Ziegler, 1982, 1990)

The principle here is that lithology is shown by the appropriate black and white symbol, whilst the depositional environment is indicated by colour.



Lithological Symbols

	Sand/sandstone and conglomerate
	Sand/sandstone
	Sand/sandstone and clay/claystone/shale
	Carbonate and sand/sandstone
	Carbonate
	Carbonate and clay/claystone/shale
	Clay/claystone/shale, some carbonate
	Clay/claystone/shale
	Organic shale
	Halite
	Anhydrite, gypsum
	Oolites, shoals
	Coal
	Batholiths
	Volcanics, local
	Major extrusives, plateau basalts

Depositional Environments (and cross lithology)

	orange	Continental, lacustrine
	yellow	Deltaic, coastal and shallow marine clastics
	green-yellow	Shallow marine, mainly shales
	aquamarine 4	Deeper marine, mainly shales
	burlywood	Deeper marine clastics
	middle cyan	Carbonates, mainly shallow marine
	light magenta	Evaporites
	white	Uninterpreted areas
	red	Major extrusives, plateau basalts





Areas of Non-deposition

	grey 90	Cratonic hinterlands (mainly low relief)
	grey	Inactive fold belts (moderate to high relief)
	grey 50	Active fold belts (high relief)

For colours see Appendix 4

For **Tectonic Symbols** see 4.7.2

Miscellaneous Symbols

	Direction of clastic influx
	Direction of marine incursion
	Direction of intra-basinal transport
	Erosional edge of map interval

4.6.2 Continental/Global Scale Maps (after Ziegler, 1989)

The principle here is that, for reasons of scale, colour alone is used to depict both lithology and depositional environment.











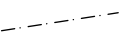

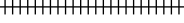
Depositional Environment and Principal Lithology

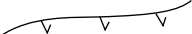
	orange	Mainly continental clastics
	yellow	Deltaic to shallow marine, mainly sands
	green-yellow	Shallow marine, mainly shales
	yellow-green	Shallow marine, clastics and carbonates
	middle cyan	Shallow marine, mainly carbonates
	tan	Evaporites and clastics
	light magenta	Mainly evaporites
	violet	Evaporites, clastics and carbonates
	dark violet	Evaporites and carbonates
	lawn green	Deeper marine clastics and/or carbonates
	burlywood	Deeper marine, mainly sands
	forest green	Basin floored by oceanic crust
	white	Uninterpreted areas
	red	Plateau basalts

For colours see Appendix 4

For **Areas of Non-deposition** see 4.6.1

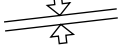
(Plate-)tectonic Symbols

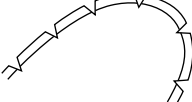
	Oceanic - continental crust boundary
	Active sea floor spreading axis
	Transform zone
	Subduction zone
	Accretionary wedge
	Oceanic trench
	Sea mount
	Continental shelf - slope break
	Orogenic front
	Centres of seismic activity, earthquake epicentres
	Active } volcanoes, volcanic centres Inactive }
	
	Linear high, 'anticlinorium', major regional high or axis of uplift
	Linear low, 'synclinorium', major regional low or basin axis
	Outline of basin subsidence

For other **Tectonic Symbols** see 4.7.2

4.7 Structural Geology

4.7.1 Faults, General Aspects

Elements of Fault Terminology

Normal and reverse faults on maps

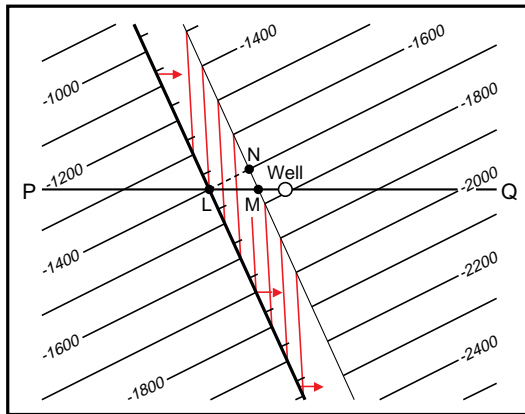

Fig.a

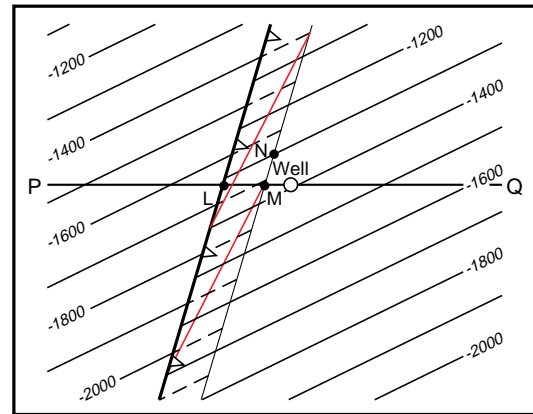

Fig.b

black - contours on marker x (e.g. seismic reflection), red - contours on fault plane

Normal and reverse faults on sections

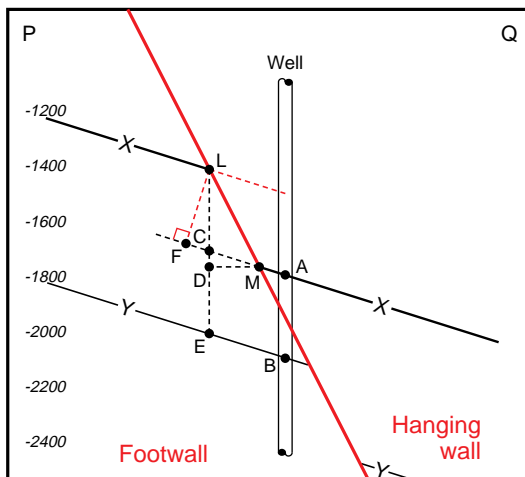

Fig.c

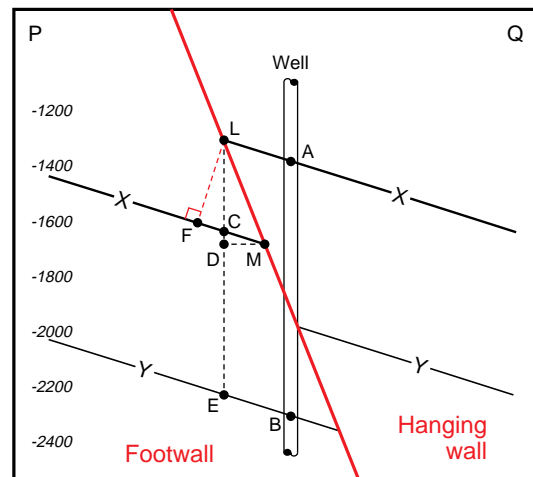

Fig.d

Terminology

Footwall and hanging wall refer to the geometrical position of the blocks, below and above the fault plane. Upthrown and downthrown describe the relative movement of the blocks.

Measures of Separation

Separations describe the geometry of the fault and have to be referred to a measurement direction (e.g. the cross-section plane or a fault-dip section). This example refers to the cross-section plane PQ (through LM).

Vertical separation in plane of section	Difference in level between L and M: -360 in Fig. a Difference in level between L and M: +400 in Fig. b
Stratigraphical separation	Vertical separation multiplied by cosine of true dip = LF in Figs. c and d
Borehole cut-out	AB - LE = -LC = vertical separation (-300) in Fig. c and LN in Fig. a
Borehole repetition	AB - CE = LC = vertical separation (+350) in Fig. d and LN in Fig. b
Measured in a fault-dip section	
Dip separation	LM in Fig. c
Note: Section PQ in Fig. c is a fault-dip section; in Fig. d, the section is not a fault-dip section.	
Throw	Vertical component of dip separation = LD
Heave	Horizontal component of dip separation = DM (Fig. c), and LM (Fig. a)

Measures of Slip

The measures below require knowledge of the fault slip direction, as evidenced directly (e.g. by slickensides at outcrop or by offset linear features such as fluvial channels) or indirectly (by stress field analysis or by seismically mappable corrugations on the fault plane).

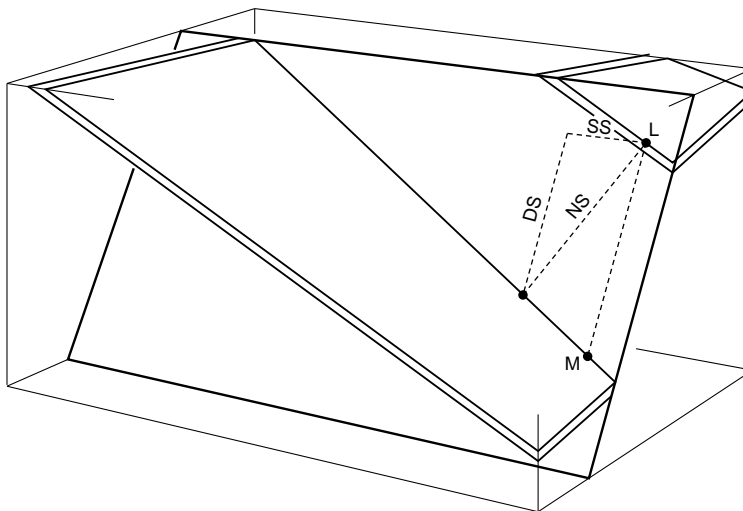

NS Net slip	The true displacement of the fault
DS Dip slip	The component of NS parallel to the dip of the fault plane
SS Strike slip	The component of NS parallel to the strike of the fault plane
LM	Dip separation

Note: DS \neq dip separation!

In beds which have been rotated after faulting, the angular relations between bedding and fault plane, combined with sense of offset, define the fault type. The example below is thus a normal fault.

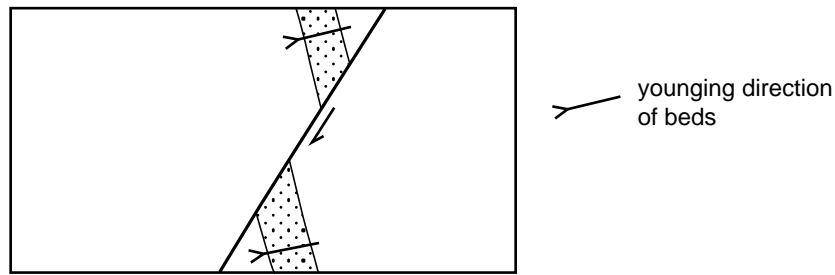

Rotated Normal Fault

4.7.2 Faults on Surface Geological and Horizon Maps

4.7.2.1 Symbols for Fault Types

- 1) Arrows indicating the dip direction of the fault plane are only required (a) if the fault type (normal, reverse) is unknown, or (b) some useful purpose is served by depicting the fault dip.
- 2) Barbs for fault type show the relative structural position of blocks and are always directed towards the hanging wall, i.e. point down the dip of the fault.
- 3) If colour is used, faults are depicted in red.
- 4) The fault symbol used must also be qualified according to reliability (see Section 4.7.2.3).

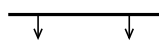
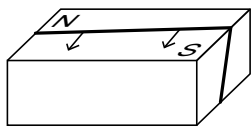

Fault, dipping south, relative structural position of blocks unknown



Fault, vertical, relative position of blocks unknown

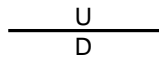

Dip of fault plane unknown, but sense of displacement known (D = downthrown, U = upthrown block)

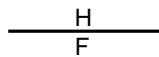

Direction of fault dip known, but sense of displacement unknown (H = hanging wall, F = footwall)

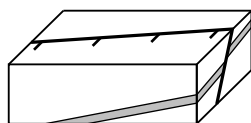

Fault, dip of fault plane unknown, barbs on downthrown side



Alternative fault symbol

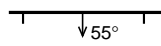
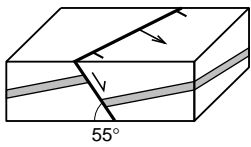

Normal fault, dipping 55° in direction of arrow, barbs on downthrown side

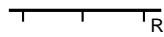
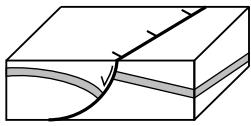

Rotational normal fault (optional)

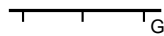
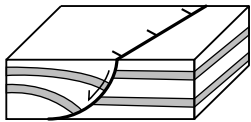

Rotational growth fault (optional)

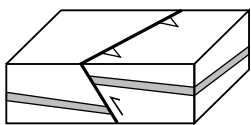

Reverse fault, unspecified high dip angle ($<30^\circ$) (barbs on the upthrown block)

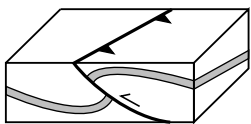

Overthrust, unspecified low dip angle ($<30^\circ$) (barbs on the upthrown block)

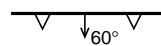
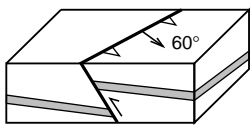

Reverse fault, dipping 60° in direction of arrow (barbs on the upthrown block)

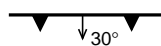
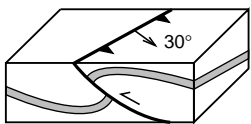

Overthrust, low angle reverse fault, dipping 30° in direction of arrow (barbs on the upthrown block)

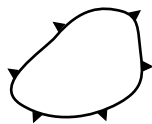
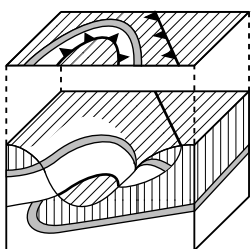

Fault inlier, fenster, window

(Saw teeth point to the higher, overthrust mass.)

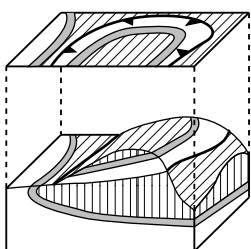

Fault outlier, klippe

(Saw teeth point to the higher, overthrust mass.)

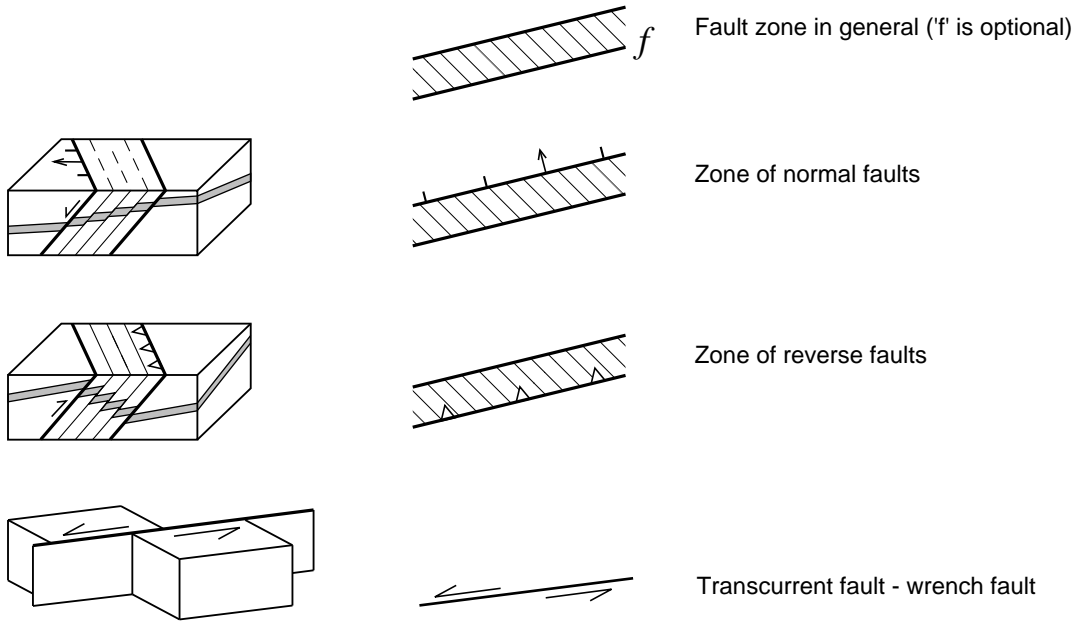

4.7.2.2 Re-activated Faults

i.e. where a fault has been re-activated with a sense of movement opposite to the original sense of movement.

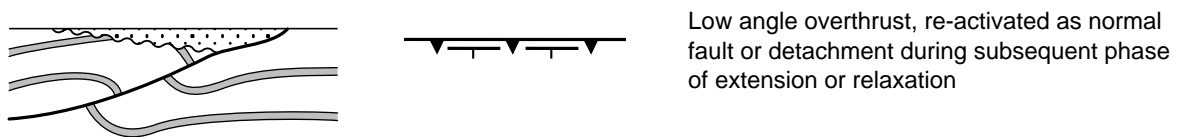
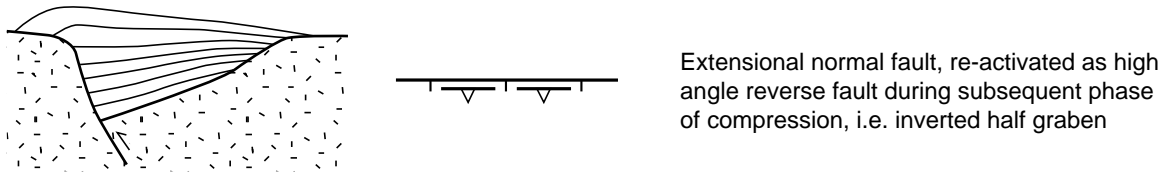

4.7.2.3 Fault Reliability and Heave

On maps

All faults should be indicated by thicker lines than contours.

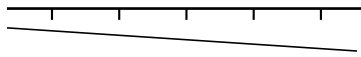

Fault position reliable, heave known

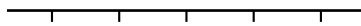

Fault position reliable, heave known but not depicted

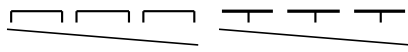

Fault position approximate, heave known
Alternative symbol

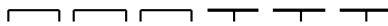

Fault position approximate, heave unknown
Alternative symbol

On maps in which the heave is not depicted, the legend must indicate whether the trace mapped is the intersection of the fault plane with footwall, hanging wall, or whether it is the fault mid-line.

All prospect and field maps used for volumetric estimates must depict the fault heave.

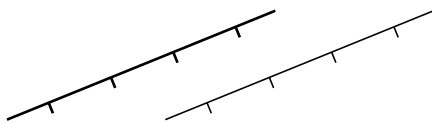

Line weight should be used to classify faults into 'large' and 'small', where these sizes are defined in the map legend.



Transcurrent fault, lateral movement sense unknown

On sections



Fault, showing relative movement



Fault, showing relative movement, presence and/or position uncertain, question marks optional



Wrench fault, showing sense of movement

⊗ away from observer

⊙ towards observer

4.7.2.4 Horizon Contours

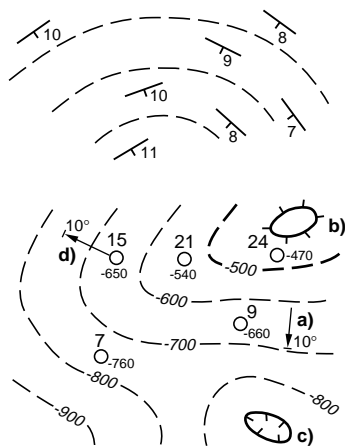

Strike lines or form lines: lines of general strike, roughly deduced from surface dips, seismic dips on uncorrelated local markers

Contours obtained from subsurface data: wells No. 7, 9 etc., showing depth of contoured horizon

- a) angle of dip of the contoured horizon
 - b) structural high
 - c) structural depression
 - d) dipmeter measurements near contoured horizon: length of arrow equal or proportional to contour spacing
- } optional

Contour values, spacing and orientation should be consistent with well depth and with dipmeter data which should always be plotted and converted to seismic TWT where necessary. Contours should be plotted with a line weight less than that used for faults. Every 5th contour should be marked with a heavier line weight. All contour values should be readable without turning the map around.

4.7.2.5 Fault-Contour Relationships

Horizon contours should be consistent with the observed fault displacements.

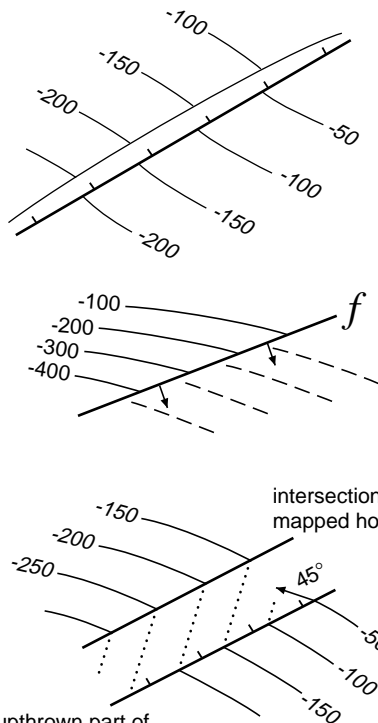

Fault with structural contours in adjacent block, relative structural position of blocks known.

Fault dipping in direction of arrow, relative structural position of blocks unknown.

Normal fault with 125 units dip separation and dip of 45°. Fault plane contours: dotted or different colour. It is optional to indicate angle of dip of the fault plane.

intersection of upthrown part of mapped horizon with fault plane

intersection of downthrown part of mapped horizon with fault plane

Fault dip is perpendicular to fault plane contours, not perpendicular to fault trace on the horizon.

The intersection of horizon contours with the fault must be consistent with the dip and shape of the fault plane. This essential quality check should be made even if fault plane contours are not presented on the final map. Dip separation across the fault should be measured perpendicular to fault plane contours (not perpendicular to fault trace) and this separation should vary smoothly along the fault.

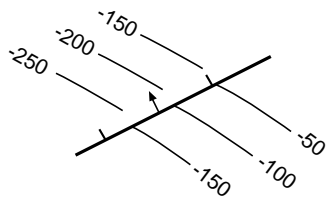

Normal fault, intersection with downthrown part of mapped horizon unknown

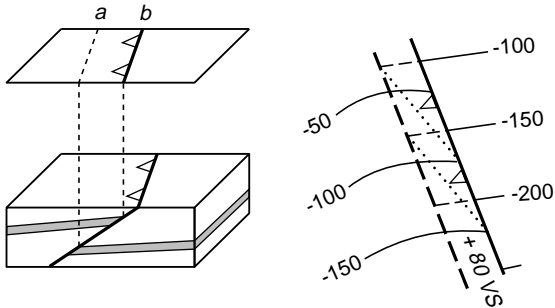

Reverse fault with dip separation of 80 units

a) intersection of downthrown part of mapped horizon with fault plane

b) intersection of upthrown part of mapped horizon with fault plane

For thrust faults, it is preferable to make separate maps for the footwall and hanging wall for clarity.

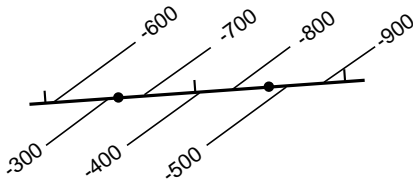

Vertical fault, structural position known

4.7.3 Folds and Flexures

These symbols should only be used where the scale of the map precludes depiction of folds using contours.

Symbols for folds are plotted in green if colours are used.



Anticlines

Axis of symmetrical anticline

Axis culmination

Axial plunge or pitch of 12°

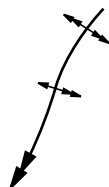

Axis of relatively steeply folded symmetrical anticline

Axis of asymmetrical anticline, one flank steeper than the other

Axial plunge relatively steep

(The dips or dip ranges should be indicated in the map legend.)

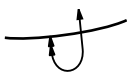

Overtured anticline

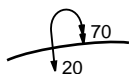

Overtured anticline - dip of normal flank 20°, of overtured flank 70°

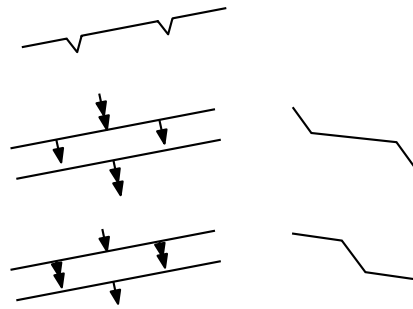

Flexures

Flexure in general, points indicate downdip

Structural terrace

Zone of steep dip, on detail map

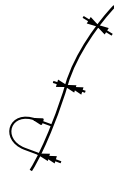

Synclines

Axis of syncline in general

Axis of asymmetrical syncline

Axis of overturned syncline

4.7.4 Dip and Strike Symbols on Surface Geological Maps

4.7.4.1 Bedding

If colour is used, dip symbols are plotted in green.



Strike and dip certain: amount of dip 12°



Strike and dip doubtful or estimated



Strike only known



Horizontal bed certain



Horizontal bed, doubtful or estimated



Vertical bed certain



Vertical bed, doubtful or estimated











Overturned bed, dip 60°





Crumpled, undulating beds with amount of average dip





Where dips are not derived from original mapping, the source of data should be indicated in the map legend (e.g. 'dips from previous maps', or 'from 3-point construction using borehole depths').

On regional maps (only), it is permitted to use the following qualitative dip symbols.

	1°
	1 - 4°
	5 - 9°
	10 - 29°
	30 - 69°
	70 - 89°
	90°
	overturned

4.7.4.2 Miscellaneous Structural Features

	Cleavage Strike and dip: amount of dip 34°
	Strike of vertical cleavage
	Horizontal cleavage

	Schistosity, Foliation Strike and dip (add barbs if several phases are recognized, e.g. )
	Strike of vertical schistosity (foliation)
	Horizontal schistosity (foliation)

	Jointing Strike and dip
	Vertical joint
	Horizontal joint

Lineation



Direction of linear element (striation, groove, slickensided on joints) shown in horizontal projection (with plunge in degrees)



Joint with direction of groove

(Point of observation is at centre of symbol at base of arrow.)

Minor Folds



Plunge and bearing of minor fold axis



ditto - with sense of fold asymmetry viewed down-plunge

4.7.5 Structural Cross-sections

Orientation

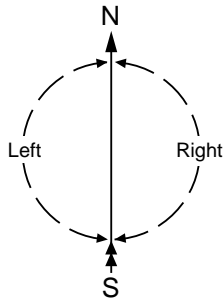

Eastern ends, including due north, of sections to be drawn on the right.

Exceptions may be made to this rule

1. in the case of a series of sections not quite parallel, some drawn slightly east and some slightly west of north
2. in the case of change of direction of a section
3. to maintain uniformity with an established practice in a particular oil or gas field

Changes of the azimuth of the section line should be marked on the section.



Seismic marker (for use on geological sections in connection with symbols)

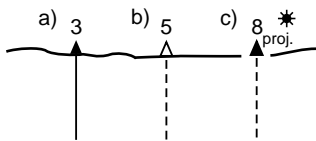

Well with number on small scale sections

- a) well on or near section line
- b) well location on or near section line
- c) well projected onto section plane, HC status symbol optional

Features projected onto the section plane should be indicated by the abbreviation "proj." unless there is a special symbol for projected. In addition, where possible the line representing the topographical surface should be interrupted.

Dip Symbols on Sections

If the section cuts the strike obliquely, reduced dips should be shown on section.

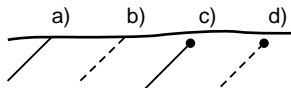

Dip measured at outcrop

- a) certain
- b) uncertain
- c) certain, projected onto section
- d) uncertain, projected onto section

Example

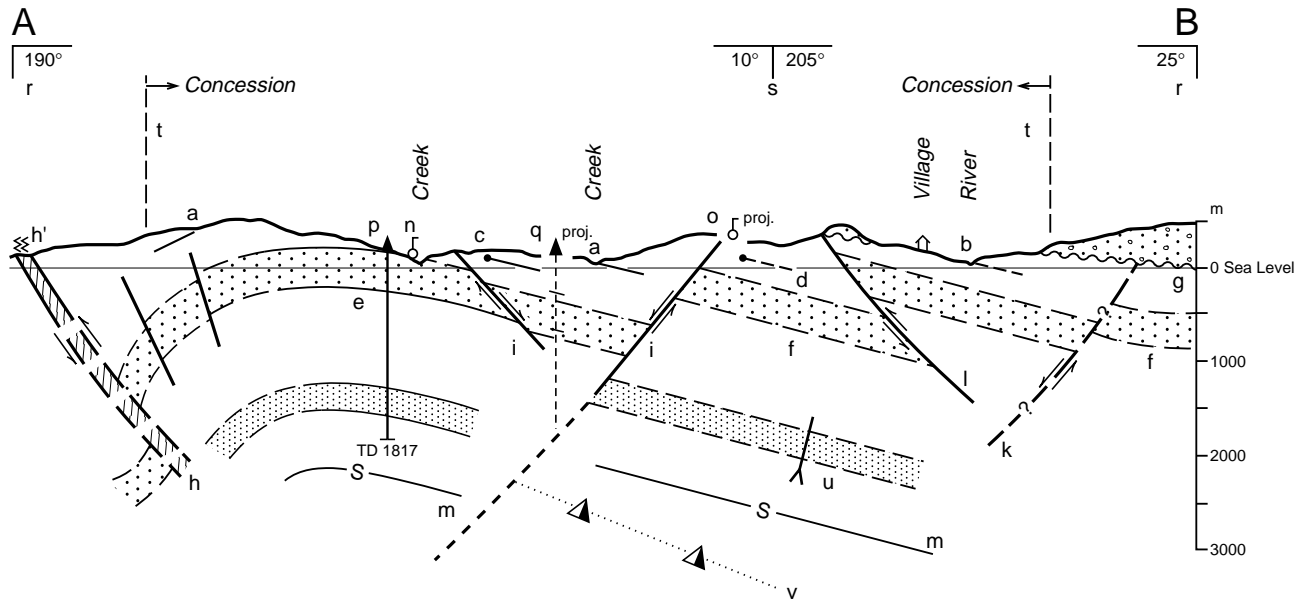

Legend

Dip	a	certain, measured in outcrop on or near section	}	see previous page	
	b	uncertain, measured in outcrop on or near section			
	c	certain, projected onto section plane			
	d	uncertain, projected onto section plane			
Formation	e	boundary, certain	}	4.4.5.1	
	f	boundary, uncertain			
Unconformity	g	unconformity		4.4.5.1	
Fault	h	fault zone	}	4.7.2.1	
	h'	strongly disturbed formation observed at surface		4.3.7.1	
	i	normal, position/existence certain		}	4.7.2.3
	k	normal, position/existence uncertain			
l	reverse, position/existence certain				
Seismic	m	marker		see previous page	
Oil seepage	n	on or near section	}	2.5.2	
	o	projected onto section plane			
Well	p	well on or near section	}	see previous page	
	q	location projected onto section plane			
Direction of section	r	azimuth of section line	}	see previous page	
	s	change of direction of section			
Concession	t	boundary		3.3.2	
Way up	u	indicates younging direction based on way-up criteria		4.7.1	
Overpressures	v	estimated top of overpressures			

4.7.6 Trap Descriptions

4.7.6.1 Basic Trap Elements

Traps are based primarily upon geometric elements, expressed either in map or cross-sectional view. They can be divided into structural and stratigraphical traps in 4 basic categories (Fig. A):

- Dip closures
 - Fault closures and structural truncation traps
 - Stratigraphical/structural traps;
 - Pure stratigraphical traps.
- } Structural traps;

In **dip closures**, trap integrity is determined primarily by the top seal and any uncertainty in the mapped structural spillpoint. In weakly faulted dip closures, a small additional risk arises from top-seal breaching by small faults.

In **fault closures and structural truncation traps**, a lateral seal (fault seal, salt flank) is also required. In fault-enhanced dip closures, a significant upside exists if the fault seals, but, if not, a large part of the trap may be unfilled due to along-fault leakage of hydrocarbons.

In **stratigraphical/structural** traps, sedimentary geometries (pinch-outs, truncational unconformities) combine with structural dips to create the trap. In addition to the top seal, fault seals or depositional lateral seals and a seat-seal may be required.

Pure stratigraphical traps can be subdivided into two types: **morphological** and **diagenetic**. In morphologic stratigraphical traps, the shape of the sedimentary body alone is sufficient to create a trap geometry, though an encasing seal lithology is still required. Diagenetic traps arise from variation of porosity and permeability consequent upon diagenetic alteration of a particular lithology, e.g. primary tight limestone and secondary porous dolomite, or the opal-CT/chert transition.

Other important aspects of traps and their description include:

- structural setting;
- timing of trap formation in relation to charge history;
- timing of trap formation in relation to one or more structural episodes;
- vertical relationships, e.g. the stacking of multiple reservoir/seal pairs or of hydrocarbon accumulations;
- lateral relationships, e.g. adjacent traps sharing common hydrocarbon-water contacts; adjacent traps exhibiting a cascading relationship such that structurally higher traps are not filled until preceding, deeper structures have been filled and spilled.

4.7.6.2 Trap Styles in Different Tectonic Settings

Rift Tectonics (Fig. B)

In continental rifts, the basic architectural unit is the half-graben, bounded by an essentially planar master fault typically 25-100 km long. This enables the definition of 3 scales of traps in rifts:

- traps at the junction between half-graben rift segments (10 - 50 km);
- traps in the dominant tilted block associated with one half-graben (5 - 15 km);
- traps on the scale of subsidiary faults breaking up the major tilted blocks (< 5 km).

In terms of trap dynamics, the timing of footwall uplift is of paramount importance. This can be assessed from sediment thickness, facies geometries, etc. Propagation of a new master fault into a quiescent area may lead to rejuvenation of uplift, with destruction of old traps by fault-breaching or by tilting, and the creation of new traps.

Figure A

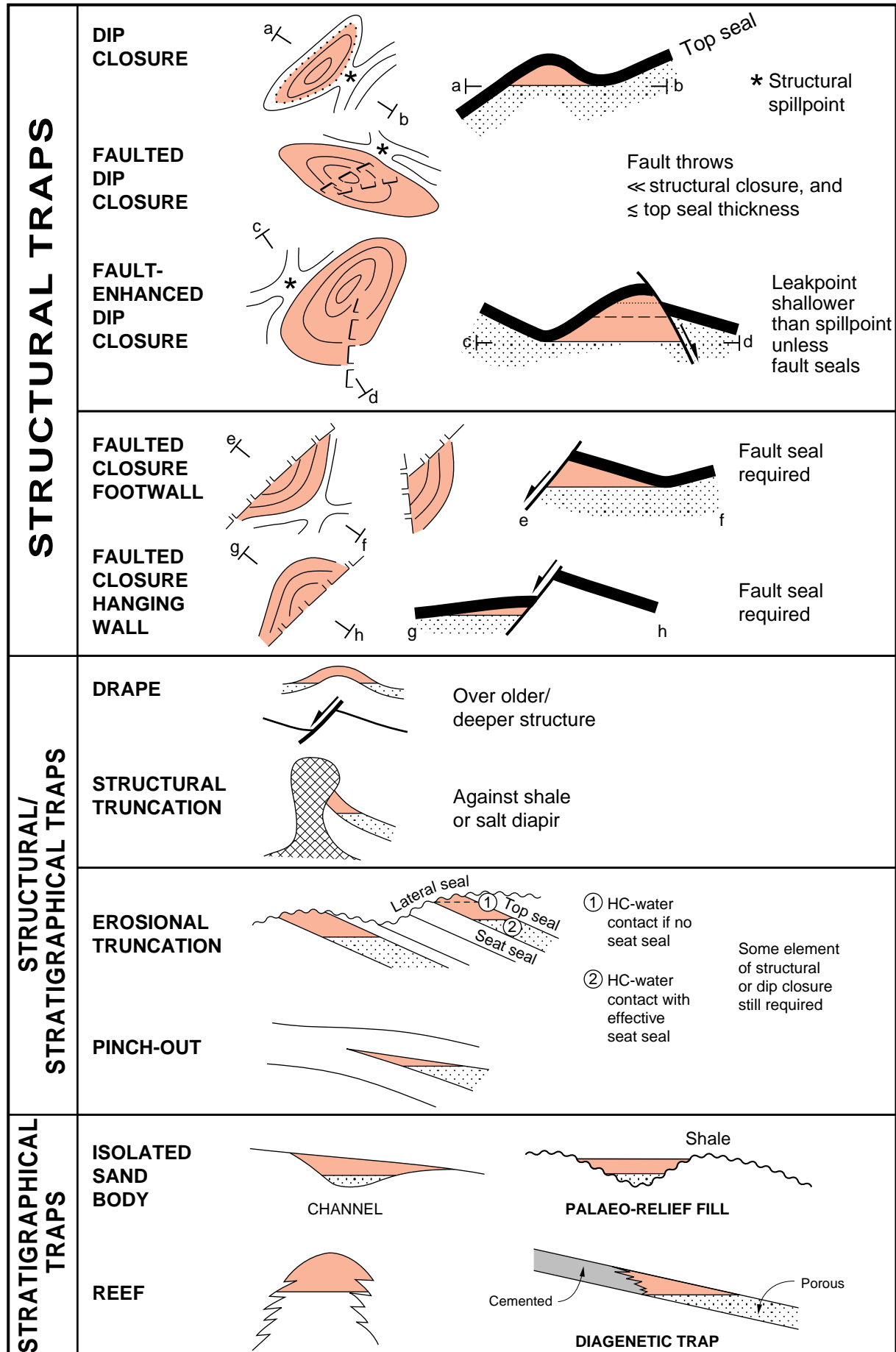

Relay zones commonly control input of clastic sediments into rifts and may give rise to local stratigraphical trapping elements, in addition to those associated with syntectonic fill on the back of tilted fault blocks. Significant folding in rift systems is unusual, although drape structures may develop in the post-rift fill above the crests of deeper fault blocks.

Salt Tectonics (Fig. C)

Salt movements may be initiated by regional extension, by local 'basement' fault movements, or by loading from superimposed sediments. Flowage of salt typically causes long-lived structuration with strong interplay between deformation and sedimentation. As a result, closures at different levels are rarely aligned vertically and there is considerable potential for stratigraphical trapping.

Typical developmental stages include low-relief salt pillows, high-relief salt diapirs, and salt withdrawal and dissolution synclines. Structural traps range from weakly faulted dip-closures above salt highs and in rim synclines, to truncation traps against the flank or underside of salt bodies. Fault geometries and patterns are highly variable, ranging from single salt-flank faults to complex networks of crestal faults arranged in parallel, 'fish-net' or radial-and-concentric patterns.

Delta Tectonics (Fig. D)

As in salt tectonics, the interplay between sedimentation and tectonics in deltas strongly influences trap types. A lateral progression from extensional growth fault systems through a domain of counter-regional faults and shale diapirs to compressional toe-thrusts is seen on well developed deltas. Delta progradation leads to overall propagation of structuration basinwards (oceanwards). Early compressional structures, which formed in deep water, may therefore be re-activated as extensional structures.

The synsedimentary nature of the faults and development of fluid overpressures results in listric fault shapes, which in turn determine the geometry of roll-over anticlines and crestal collapse fault systems. Stacked accumulations behind major faults are common. The majority of traps are fault-bounded, necessitating accurate fault-seal assessment.

Wrench Tectonics (Fig. E)

The dominant characteristic of strike-slip faulting is the *en echelon* arrangement of traps. Buckle folding and differential vertical movements between *en echelon* faults create anticlinal closures of different orientations. Dramatic vertical closures are not seen in pure strike-slip systems. Larger reverse or normal displacements are the results of transpression and transtension, or may be the expression of restraining or releasing bends in the fault system. At offsets between major wrench faults, such bends develop into significant pull-apart grabens or compressional pop-ups, in which the full range of basement-rooted extensional and compressional trap geometries are respectively found.

Thrust Tectonics and Reverse Faulting (Fig. F)

Folds of large amplitude and with steep limb dips are commonly associated with thrust tectonics. They may originate from buckle folding which precedes faulting, or may form as hanging wall folds above curved or stepped thrust planes; such thrust plane geometries are controlled by the mechanical layering of the deformed sequence. Both laterally adjacent and vertically stacked traps can be expected.

Traps develop sequentially, typically propagating towards the foreland. Out-of-sequence thrusts may result from the interplay of sedimentation and tectonics and due to variations in the quality of the detachment on which the thrust sheets move.

Inversion Tectonics (Fig. G)

Inversion tectonics produces complex fault shapes and trap geometries. Traps and reservoir bodies may be laterally offset from one another at different structural levels. Early traps may have been breached by later fault movements, although not all faults are necessarily reactivated during inversion. Compressional structures often exhibit high relief and steep dips, and may propagate along detachment horizons into regions which were unaffected by the initial extensional phase. Because the stress fields causing extension and compression are rarely coaxial, many inversion structures exhibit a component of strike-slip movement, with associated *en echelon* characteristics. As a result, strike-slip and inversion tectonics are easily confused.

Figure B

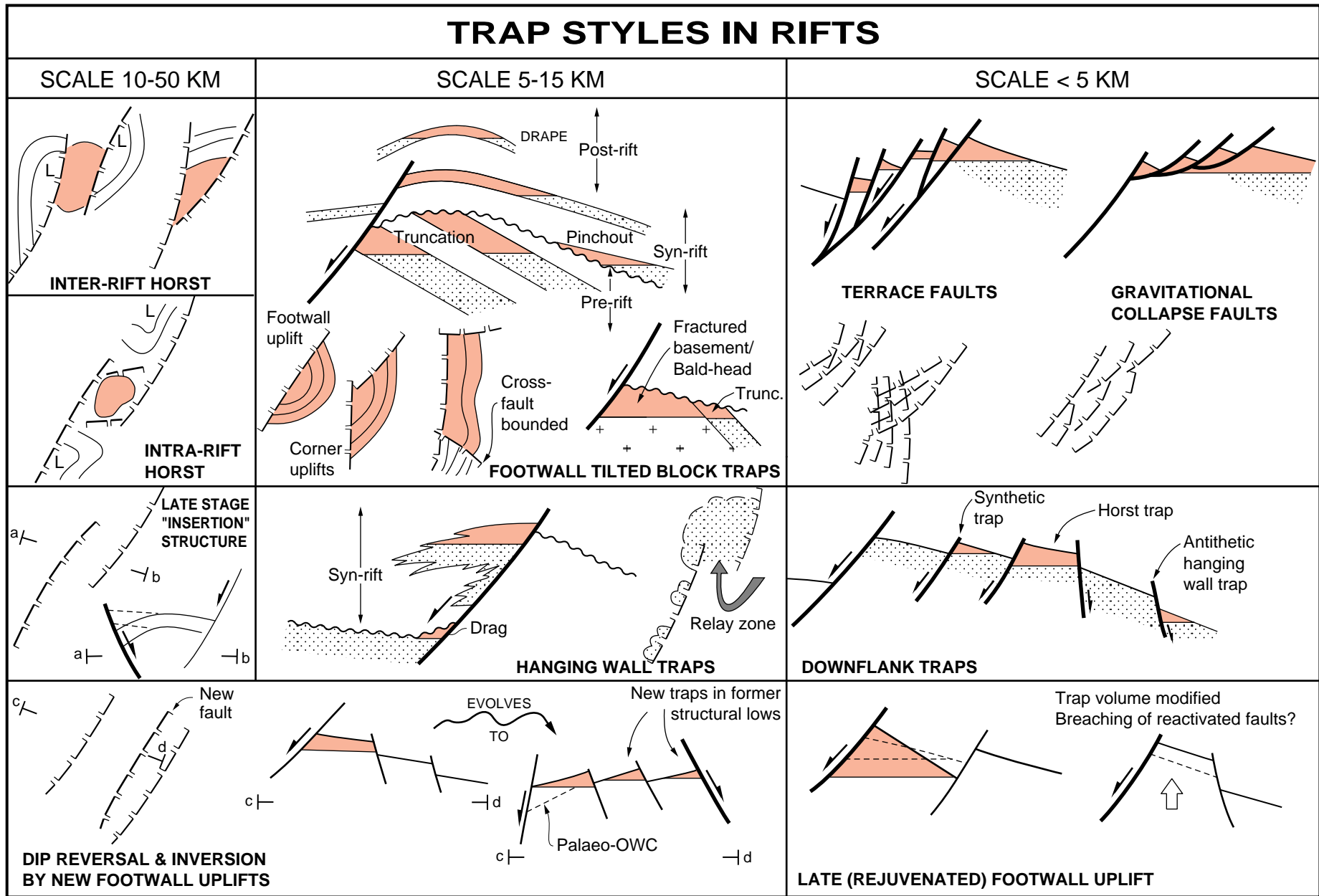

TRAP STYLES IN SALT TECTONICS

"TRADITIONAL" TRAP STYLES

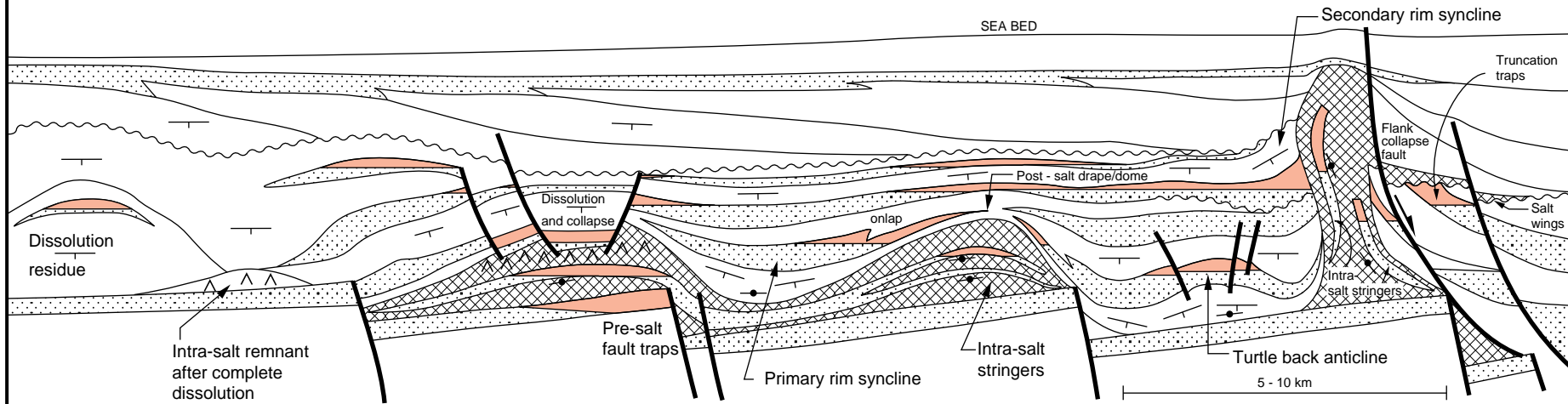

"GULF COAST" TRAP STYLES

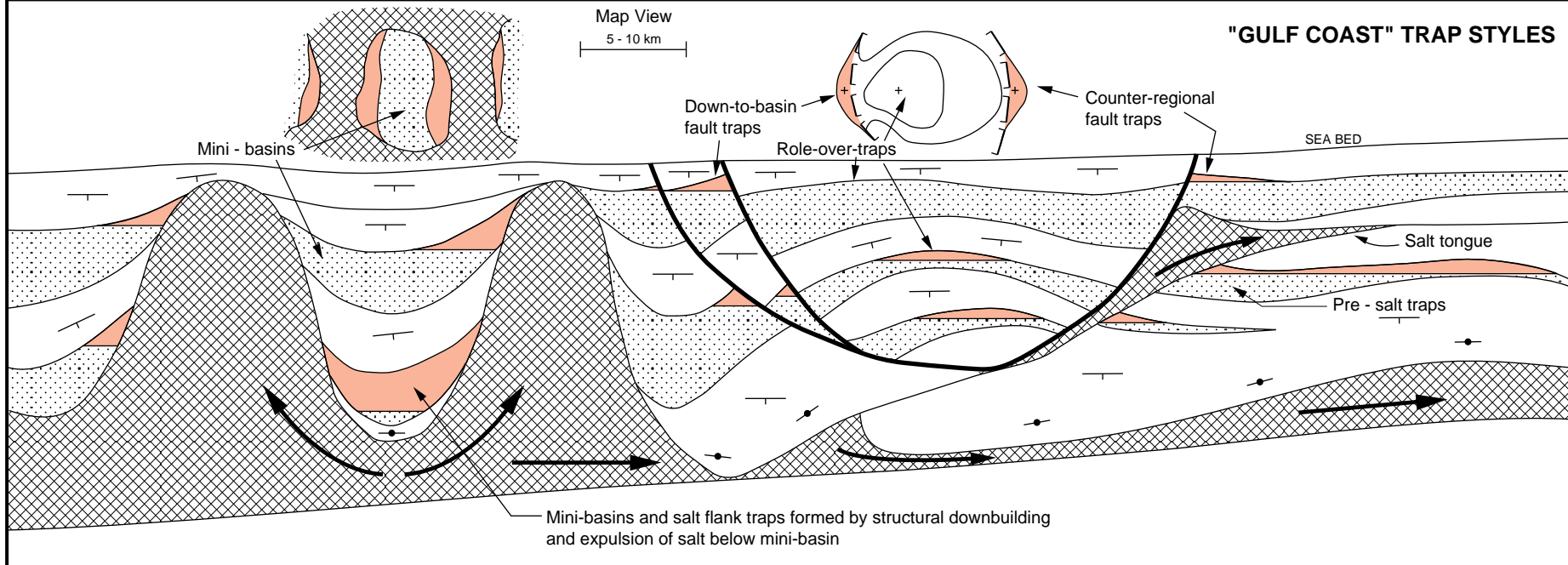
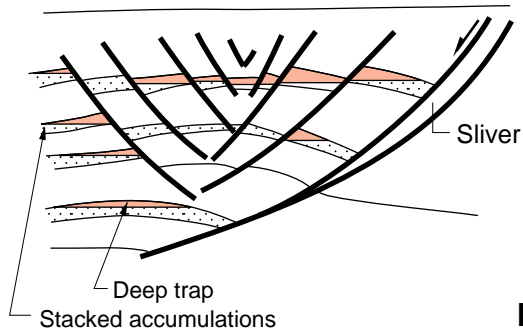

Figure C

TRAP STYLES IN DELTA TECTONICS

COLLAPSED CREST



SEQUENTIAL DOWN-TO-BASIN FAULTS

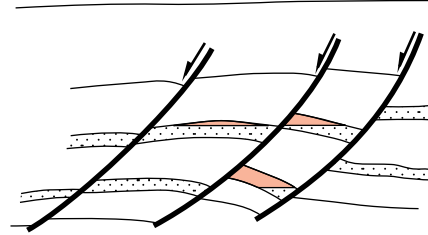

SIMPLE ROLLOVER

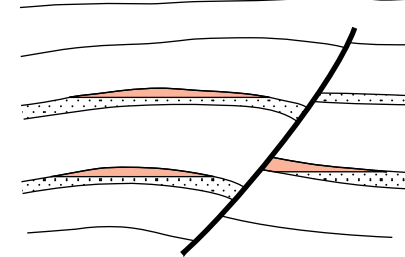

LANDWARD POSITIONS - EXTENSIONAL TRAP TYPES

BURIED TOE THRUST

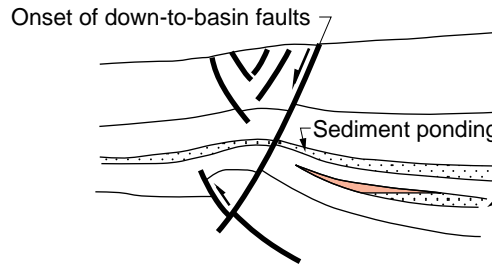

COUNTER-REGIONAL FAULT ABOVE SHALE DOME

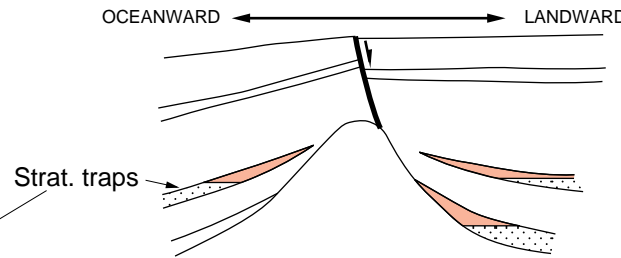

BACK-TO-BACK STRUCTURE

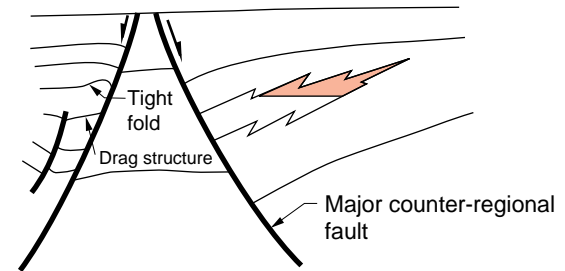

OCEANWARD & SLOPE POSITIONS - DIAPYRIC & COMPRESSIONAL TRAPS

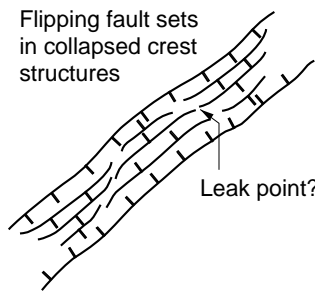
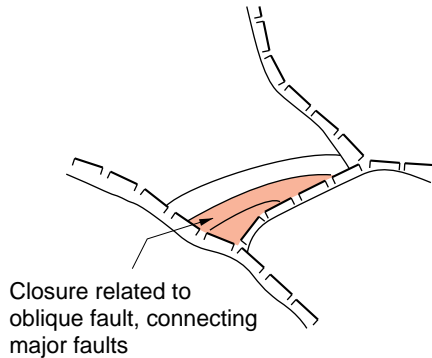
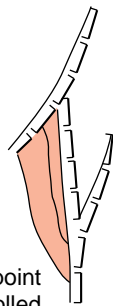

Leak point?

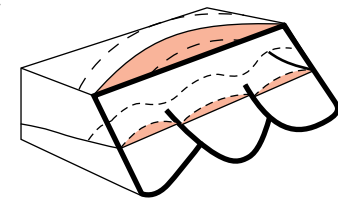
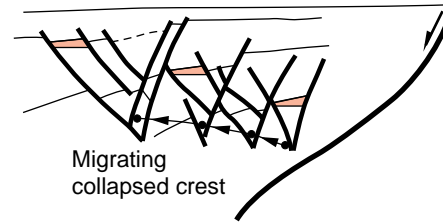

SPECIAL CASES

TRAP STYLES IN WRENCH TECTONICS

Figure E

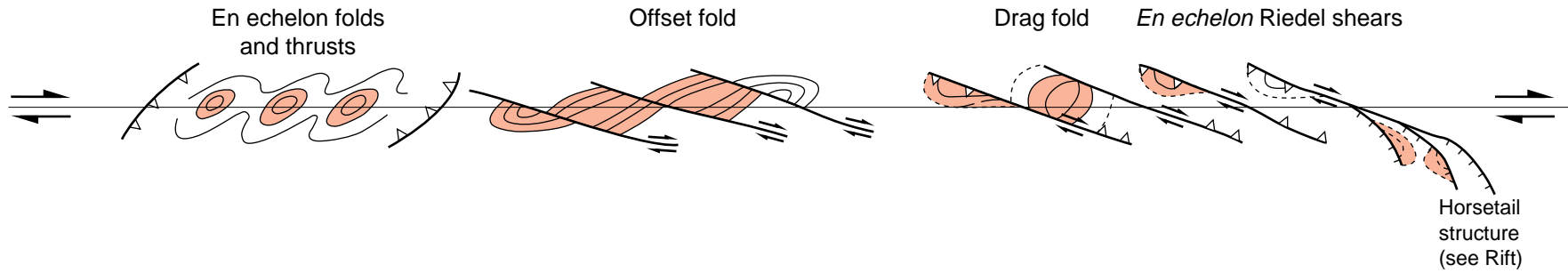

SINGLE DEEP-SEATED BASEMENT FAULT

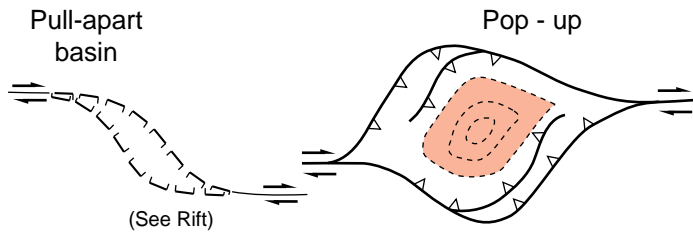

OFFSET WRENCH FAULTS

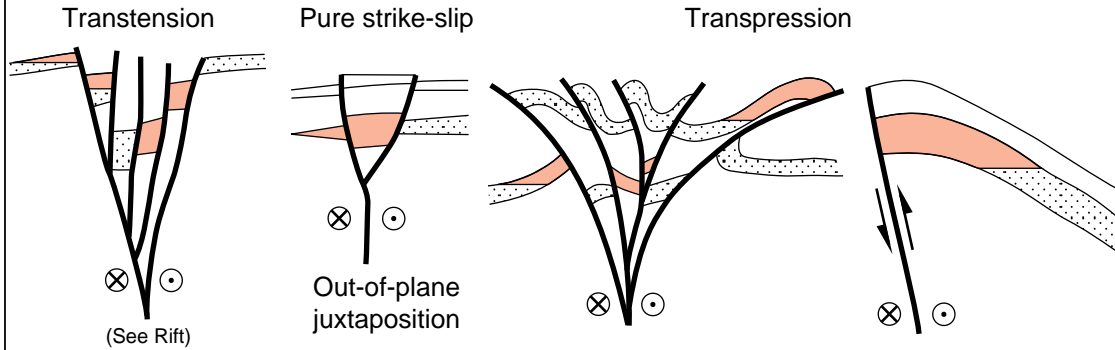

FLOWER STRUCTURES

TRAP STYLES IN THRUST TECTONICS

Figure F

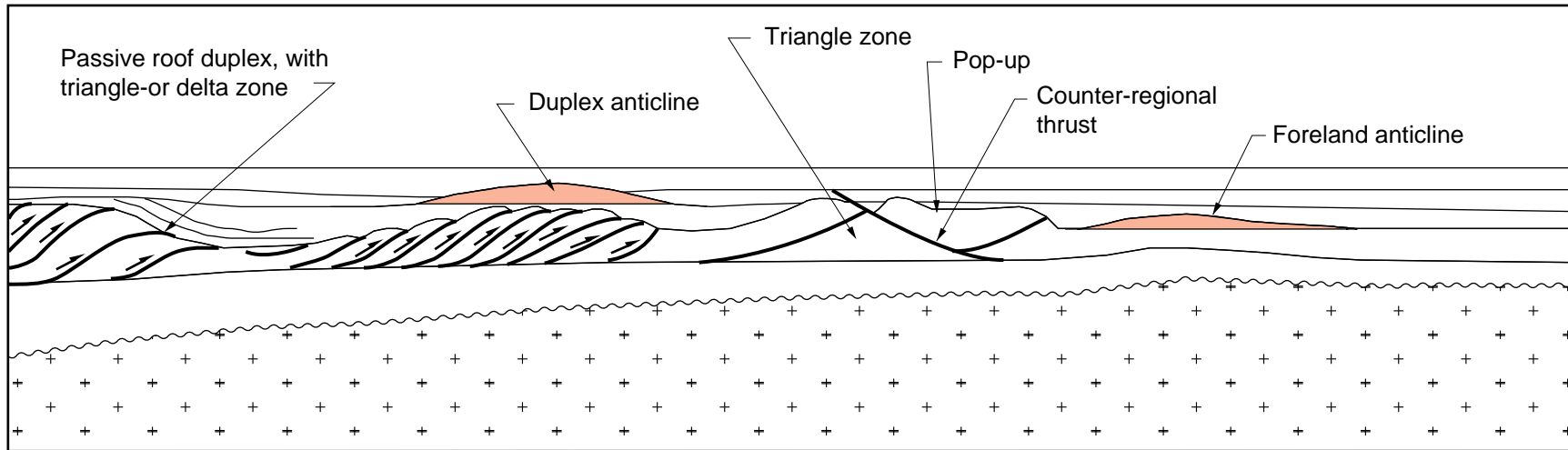
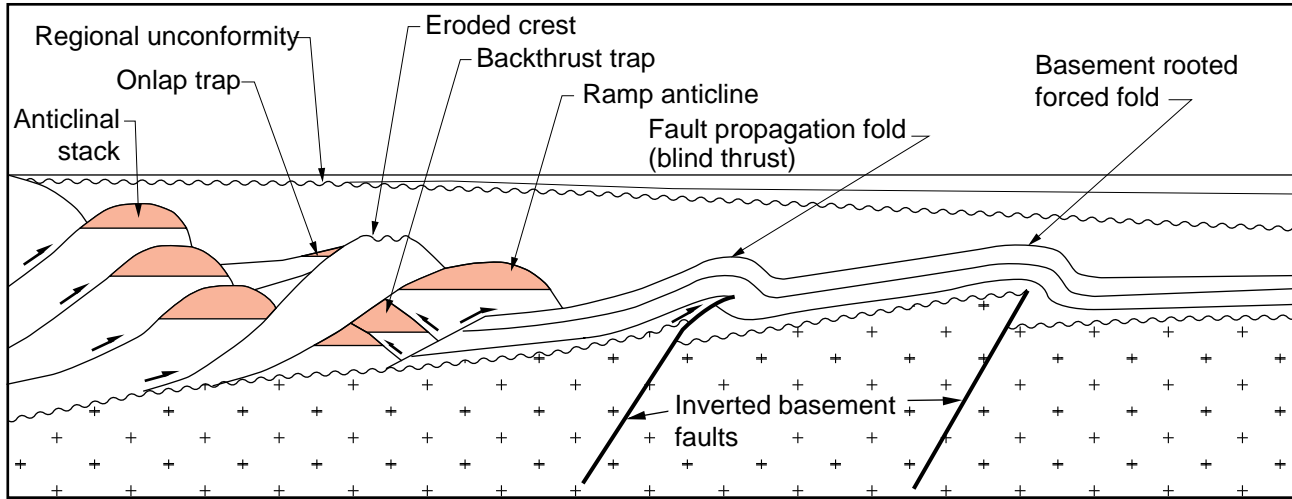

TRAP STYLES IN INVERSION TECTONICS

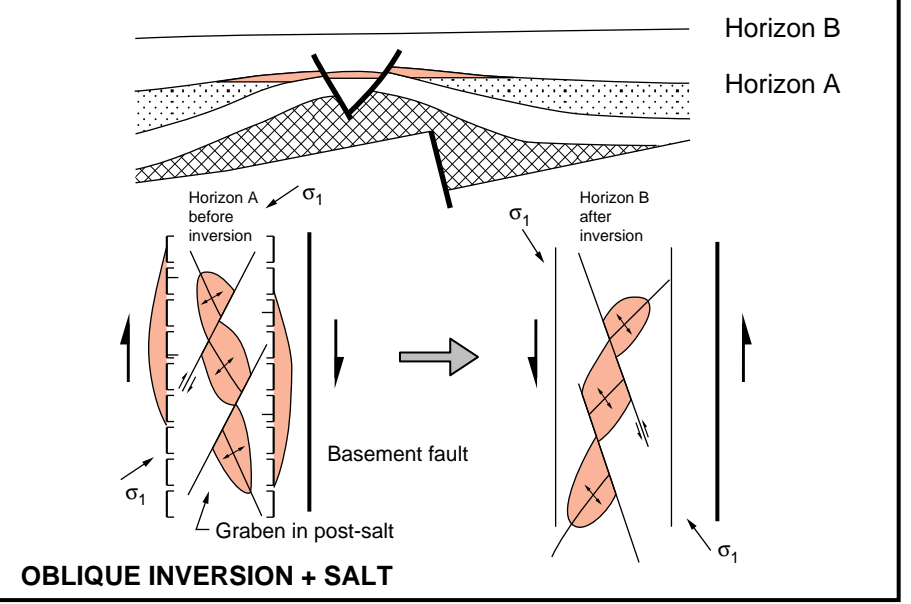
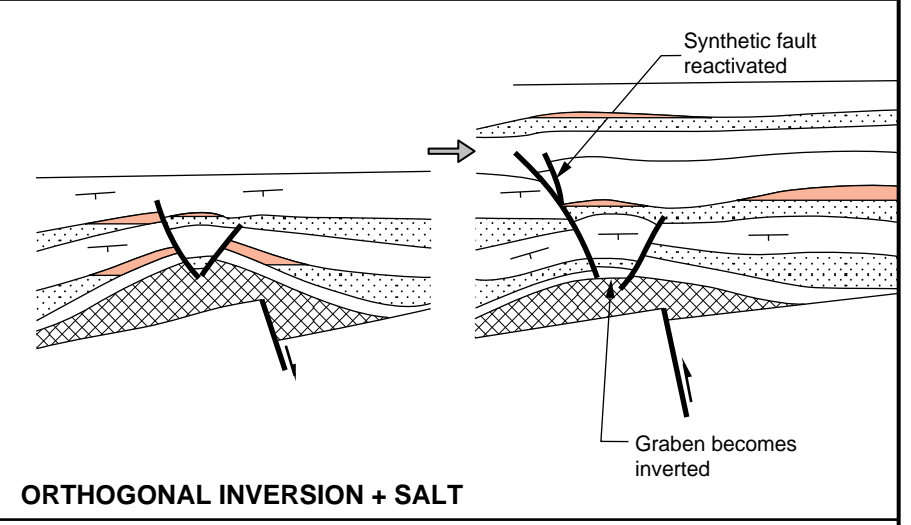
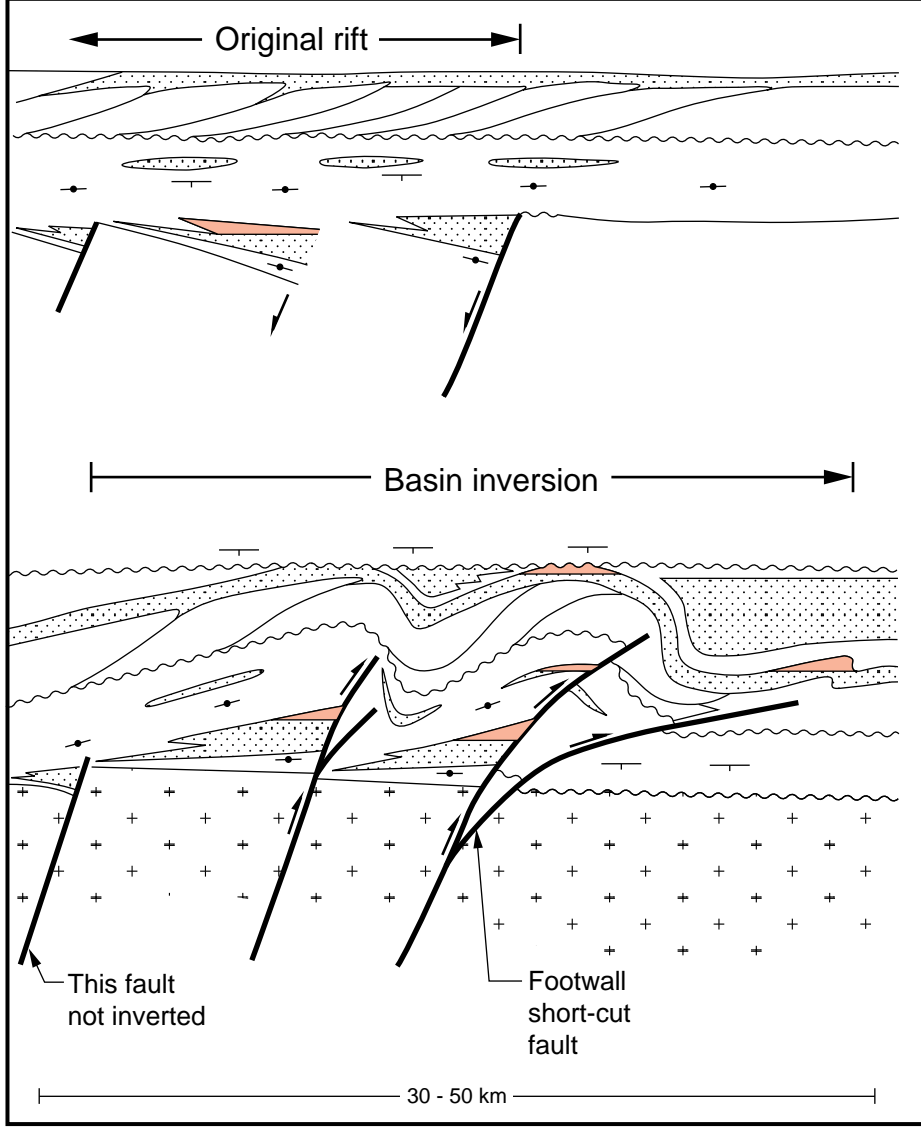
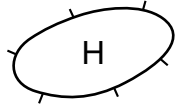

Figure G

4.7.7 Closures on Play, Lead and Prospect Maps

4.7.7.1 Structural Closure



Structural closure in general, dip closure

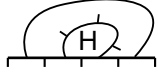

Fault closure, type of fault may be specified by using appropriate symbol

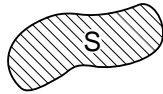

Intrusion induced closure. Nature of intrusion to be indicated by one of the following abbreviations:

E = evaporite

S = salt

Cl = clay

Vo = volcanic

Ig = igneous

4.7.7.2 Non-structural Closure



Non-structural closure in general



Non-structural closure, unconformity related

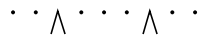

Non-structural closure by facies variation (wedge-out)



Non-structural closure by facies variation
(depositional permeability barrier)

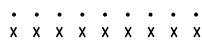

Non-structural closure by diagenetic variation
(permeability barrier due to cementation)



Non-structural closure by hydrodynamic trapping

5.0 GEOCHEMISTRY









5.1 Source Rocks

5.1.1 Source Rock Type

Source rock (SR), type not known

51101				
	Source rock	Marginal source rock	Good source rock	Very good source rock

Source rock (SR), type known

51102				
	Oil source rock	Marginal oil source rock	Good oil source rock	Very good oil source rock
				
	Gas source rock	Marginal gas source rock	Good gas source rock	Very good gas source rock

The above symbols can be combined with an index to indicate maturity if known.

		
Immature source rock	Mature source rock	Postmature source rock

5.1.2 Source Rock Evaluation

5.1.2.1 Interpretation of Rock Eval Data

Guidelines for the interpretation of Rock Eval data can be summarized as follows:

S_2	2 kg/ton of rock; no source rock for oil, some potential for gas
	2-5 kg/ton of rock; moderate source rock
	5-20 kg/ton of rock; good source rock
	>20 kg/ton of rock; excellent source rock
$HI = \frac{S_2}{TOC} \times 100$	<150; source rock for gas only
	150-300; source rock for gas and some oil
	> 300; source rock for oil and gas

S_2	Hydrocarbons released during pyrolysis of the samples (up to 550°C)
HI	Hydrogen Index
TOC	Total Organic Carbon

5.1.2.2 Van Krevelen Classification of Kerogen Types



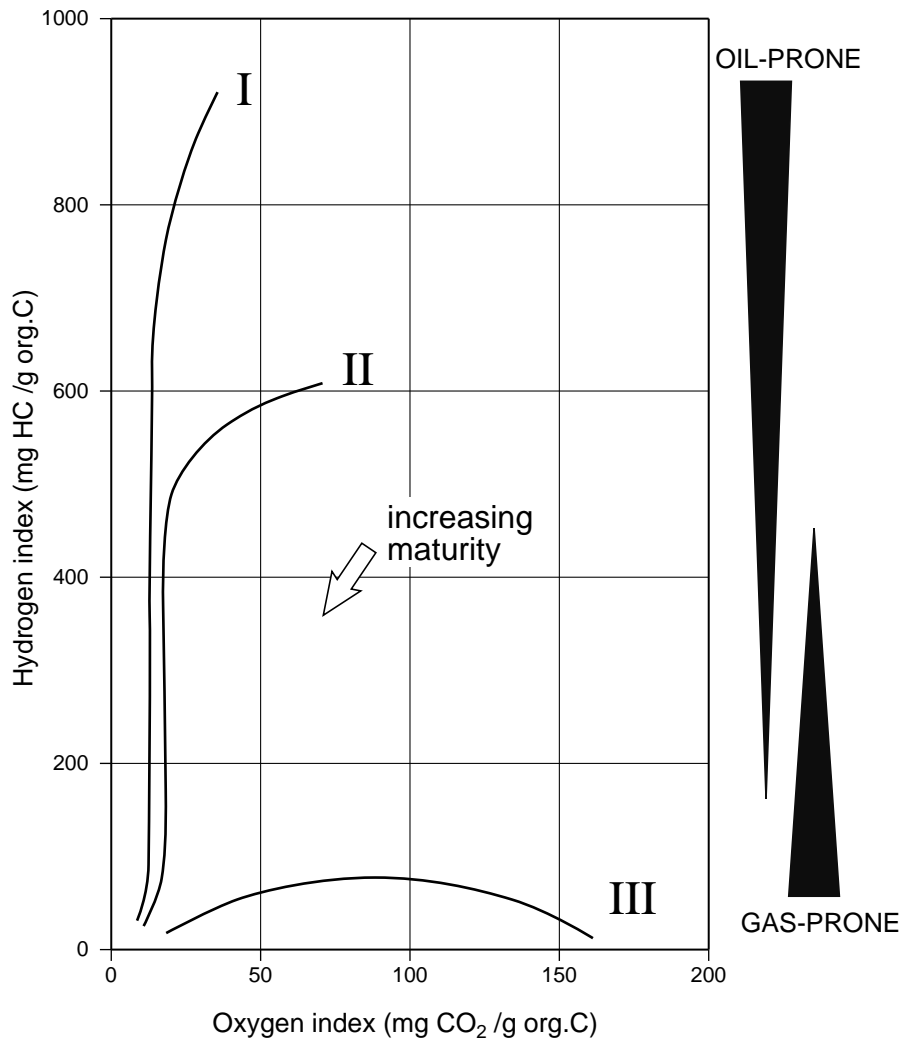

Rock Eval data are plotted on a Van Krevelen diagram. Depending on their position, samples can be typed as Type I, II or III source rock.



Identification of source rock type from this diagram can not be made without consideration of the maturity of the source rock.

5.2 Source Rock Maturity and Hydrocarbon Generation

5.2.1 Maturity Zones

	Colour	VR	Maturity Zones	T _{max} (Rock Eval)
	yellow	< 0.62	Immature	< 435°C
	orange	0.62 - 1.2	Mature for oil generation	ca. 435 - 450°C
	green-yellow	1.2 - 2.4	Mature for gas generation Postmature for oil generation	> 470°C
	violet	> 2.4	Postmature for both oil and gas	

For colours see Appendix 4

VR = Vitrinite reflectance

VR/M = Vitrinite reflectance/measured

VR/E = Vitrinite reflectance/estimated

5.2.2 Burial Graph

Essential items to be shown on a burial graph and its legend are:

- Time scale horizontal
- Depth scale vertical
- Datum
- Surface temperature
- Lithological column giving depth and gross lithology and major component percentages averaged over major stratigraphical/vertical intervals (~ 300 m /1000' or more)



Example

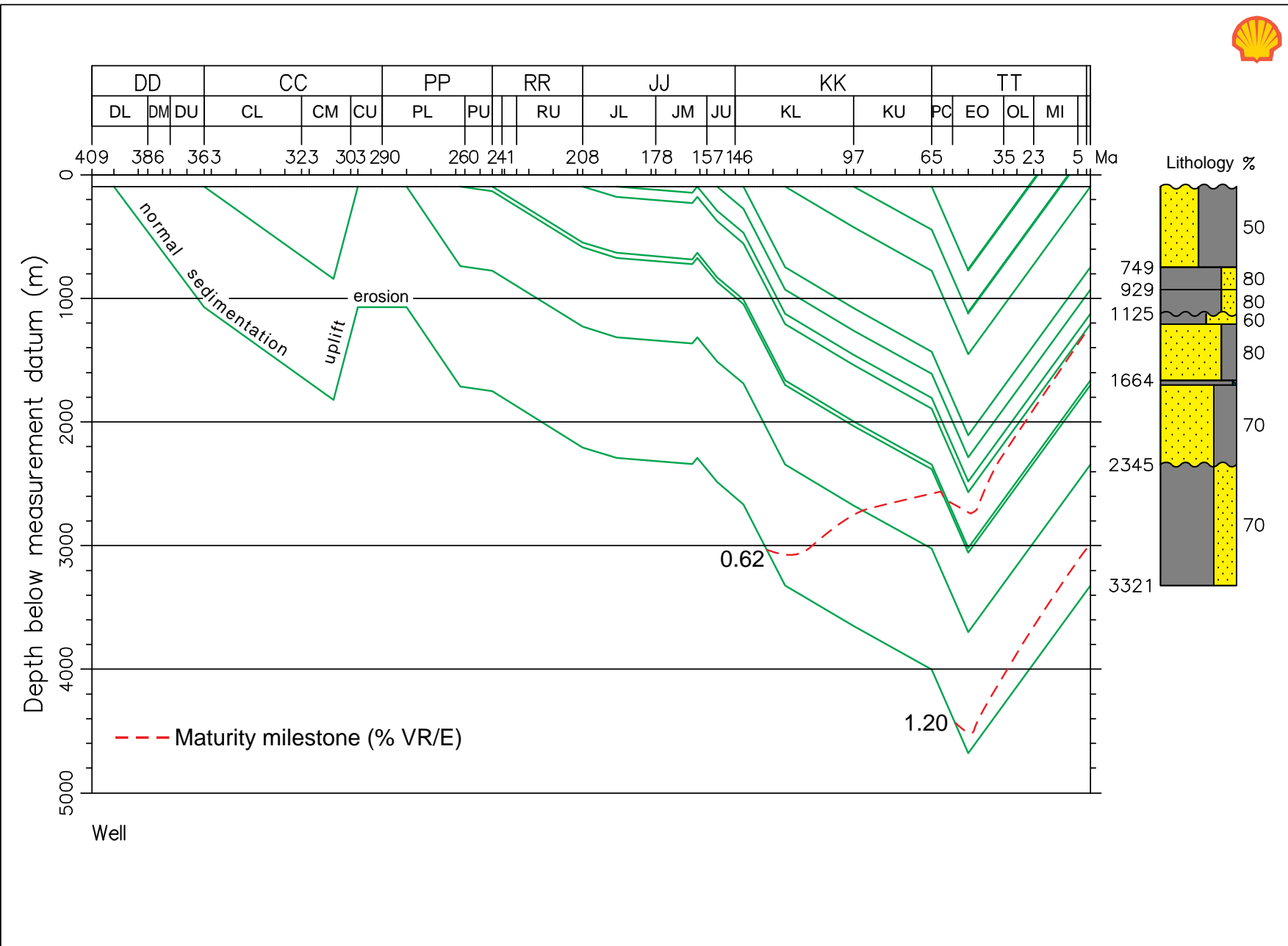

Well

5.2.3 Maturity vs. Depth Graph

The vertical (depth) axis of this graph is in arithmetic scale, and the horizontal (maturity) axis in logarithmic scale. The maturity/depth trend so plotted should be linear. Reconstruction of removed overburden is estimated by upward extrapolation to the VR 0.2 surface intercept.

Example

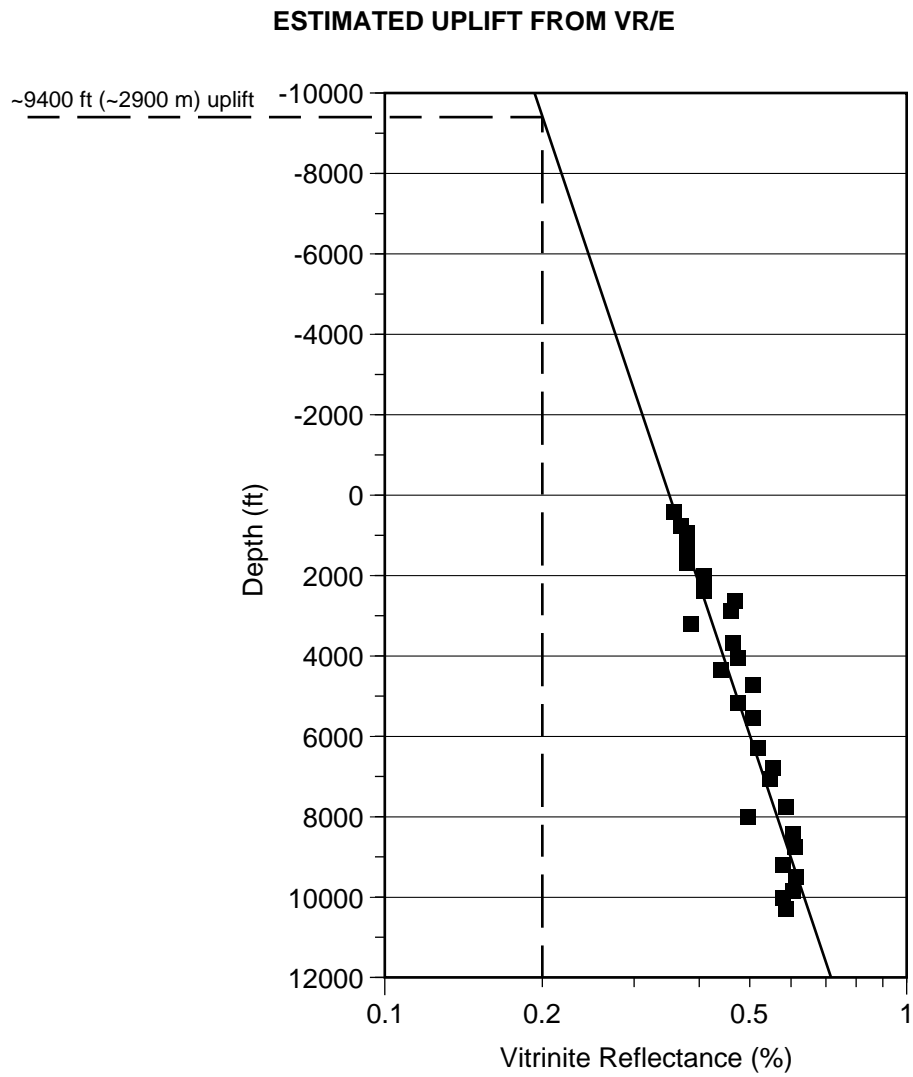

6.0 GEOPHYSICS

6.1 Seismic

6.1.1 Seismic Acquisition and Location Maps

The nature of the seismic stations must be specified in the legend of the map: e.g. position of ship's antennae, centre of shot array, centre of first receiver array, common mid-point, centre of bin position, etc. Stations and seismic lines are numbered in alphanumeric characters. Line names should be given in bolder font than station numbers.

Line names should, as far as possible, be unique, with a maximum of 10 characters. This is frequently facilitated by inclusion of the year of the survey as 2 digits within the line name. If feasible, the line name should appear at both ends of the line.

Station numbers should appear at the start and end of lines and at regular distances along the line. Stations should be annotated with round whole numbers where possible; a maximum of five digits should be used for the station number.

3D surveys are rarely presented in detail on seismic location maps, but rather a polygon outlining the survey area is used together with the survey name. The nature of the coverage represented by this box should be specified in the legend: e.g. shotpoint (SP) coverage, common mid-point coverage, full-fold common mid-point coverage, fully migrated data coverage, etc.

Seismic Station Representation

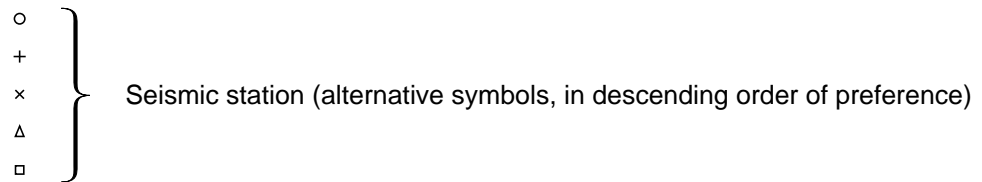

Seismic Line Representation

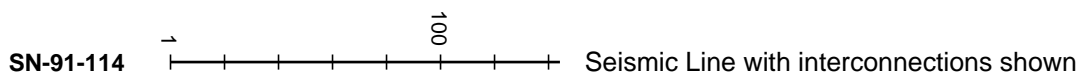
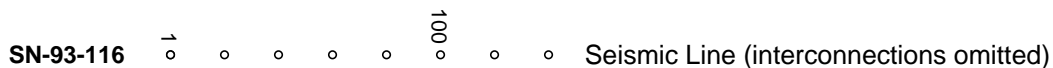

Example of Seismic Map

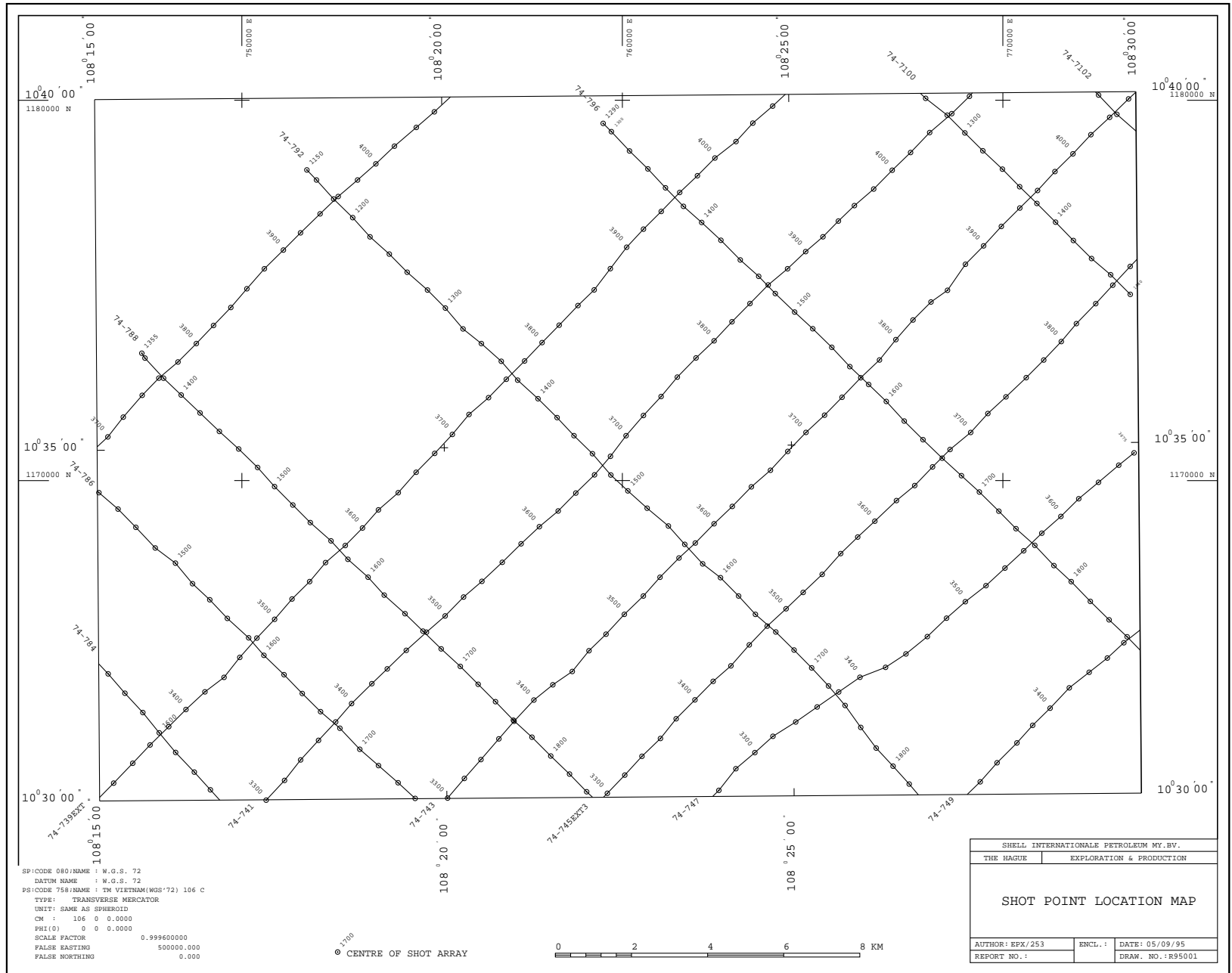

6.1.2 Seismic Processing and Display

6.1.2.1 Side Label

The following data should be recorded on the side label of a processed seismic section.

General

Company name
Survey name and date of survey
Line number.
Title - e.g. zero-phase stack or migration
Shooting direction
Shotpoint range

Recording Parameters

Acquisition contractor
Vessel name
Acquisition date
Nominal fold
Energy source type
Source interval
Source depth
Source array specification
Gun delay/Instrument delay
Receiver type
Number of receivers per group
Group interval/station interval
Receiver array specification
Cable depth
Near offset
Far offset
Recording instrument
Recording filters
 High-cut Hz dB/Oct
 Low-cut Hz dB/Oct
Recording polarity
Acquisition record length
Acquisition sample rate
Field tape format
Sketch of acquisition layout

Processing Details and Parameters

Processing contractor
Processing date/location
Processing record length
Processing sample rate, anti-alias filter, parameters (zero/min phase)
Spherical divergence correction
Statics correction, method, parameters/
refraction statics
Trace editing, method, parameters
Velocity filtering
 Cut-off velocities used, dB attenuation
 at these velocities
 Other parameters (taper)
Adjacent trace summation

Deconvolution

Type, trace by trace, or panel size
Operator length
Gap length
Auto-correlation design window(s)
Application window(s)
White noise added

CMP-gathering

- /Initial velocity analysis

- /Residual statics, type, pilot trace parameters, gates

DMO correction

Velocities used

Other parameters, dip limits, anti-alias protection, No. of
offset planes

Velocity analysis

Type, interval

Mute

Scaling

DMO stack (specify weight function or substack ranges
used - inner trace, high angle etc.)

DAS, FX decon, zero-phasing filter, as applicable

Migration

Algorithm (specify parameters)

Dip limitations, step size/bandwidth if applicable

Type of velocity input

Conversion to acoustic impedance

Time variant filtering

- 6 dB points

Slopes

Scaling

Gates

Overlap

Display Parameters

Scales

Horizontal

Vertical

Polarity

Plotting parameters (bias, gain)

Datum level

Convention used for SP annotation

Map of line locations

Co-ordinate system

Display Scales

Section scales:

horizontal scale:1:50,000 vertical scale: 2.5 or 5 cm/s

horizontal scale:1:25,000 vertical scale: 10 or 20 cm/s

horizontal scale:1:12,500 vertical scale: 10 or 20 cm/s

Time/horizon slices: scale: 1:25,000 or 1:50,000

Notes:

- 1) In addition to the relevant acquisition and processing items of a 2D seismic label, the label of a 3D survey should contain: in-line number (and cross-line numbers) or cross-line number (and in-line numbers); a drawing of the configuration of the sources and streamers/swath configuration; and a map of the survey.
- 2) SI units are to be used.

6.1.2.2 Data along Section

The following data should be recorded along the top of the processed seismic section.

Velocities (Stacking or Migration) Ground level elevation
Intersecting lines and shotpoints of intersections Wells
Processing datum, where varying

In areas of geological complexity, where outcrop information would be of use in constraining the seismic interpretation (e.g. in rift basins, or fold and thrust belts), it is strongly recommended that surface geological data is recorded along the elevation profile on top of the seismic section.

6.1.2.3 Polarity Conventions

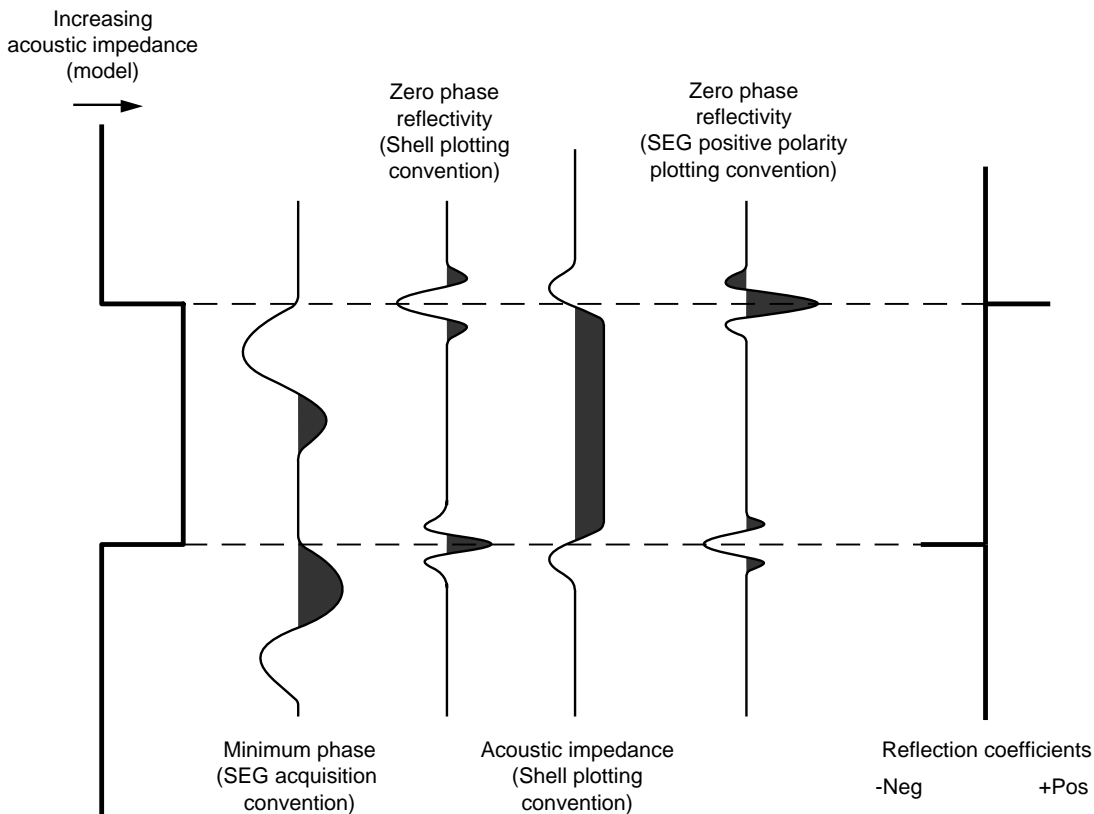

6.1.3 Seismic Interpretation

Seismic interpretation is now commonly performed on interpretation workstations. These are designed to enable data to be visualized on a workstation screen and as such these images are fit for purpose. However, if these screen displays are to be reproduced in formal documents they should follow the same standards as other figures, have a drawing number and be properly archived. The "screen-dump" rarely contains sufficient information to be used unaltered in a report, and it should only be regarded as a means of capturing information for later inclusion in a more complete figure.

The scale of the final figure should be considered when making such a screen capture. Usually the workstation screen resolution is the limiting factor in the resolution of the final figure, so the proposed figure should be displayed using the full area of the workstation screen and then reduced during plotting and reproduction.

Data sets used should clearly be stipulated on sections, structural maps and attribute maps.

Examples:

- Minimum phase migrated stack
- Zero phase high angle migrated stack
- Acoustic impedance transform etc.

6.1.3.1 Interpreted Seismic Sections

Horizons should be drawn as full coloured lines. In case of uncertain interpretation (doubtful correlation/poor reflection), the line should be dashed (see Section 6.1.3.4). All displayed interpreted horizons should be identified either on the section or in a colour-coded legend.

Faults should be drawn as full lines, or dashed in case of uncertainty (see Section 6.1.3.4). In the case of assigned faults, fault names and colours should be listed; colours should correspond to those on associated maps.

Wells should be indicated with a  symbol at the top of the section; the well name and status should be added (Sections 2.1.2.1 and 2.1.2.2). The well track should be indicated with a solid line when in the section, and with a dashed line when projected onto the section. Distance and direction of projection should be mentioned.

When portions of seismic sections are used as figures or enclosures in reports, the following information should always be indicated: general information, line name, shotpoints, intersections, line orientation and vertical and horizontal scales (conventions in Section 6.1.2). The scale of the section (and the scale units) should be shown on both axes, and the orientation of the section annotated. In addition, for 3D arbitrary lines, the inline/crossline number of all segment nodes and orientation of each segment should be indicated. In the case of time slices, TWT (two-way time) should be indicated. For colour displays, a scaled colour bar should be added.

6.1.3.2 Seismic Attribute Maps

These maps display horizon attributes extracted from seismic data, e.g. two-way time isochore, amplitude, dip, and azimuth. As any map, they require co-ordinates, a projection system and a scale bar.

The attribute displayed should be clearly indicated, as should its horizon and how it was extracted. A colour scale with attribute units should be added. Well symbols as in Chapter 2.1 should be displayed. They should be positioned at the location where the displayed horizon is penetrated. See Section 6.1.3.4 for treatment of seismic uncertainty.

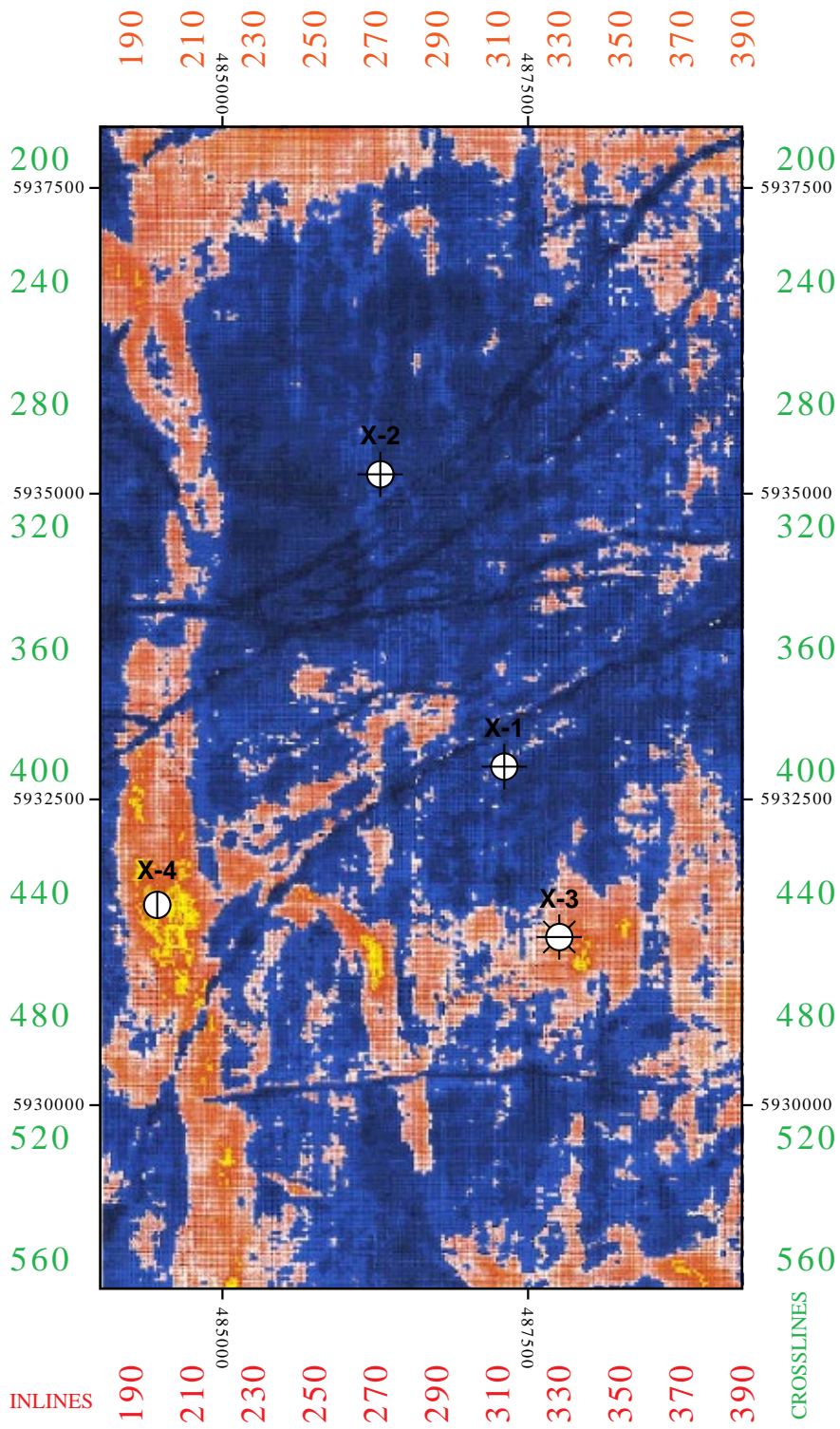

This map was obtained by measuring the RMS amplitude in a 24 ms window around the top yyyyyyy reflection

RMS AMPLITUDE (arbitrary unit)

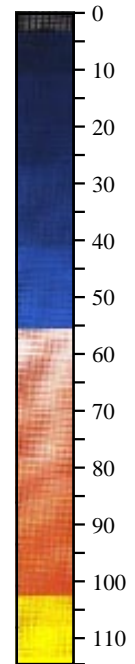

Spheroid Clarke 1866
 Datum European
 Projection System Transverse Mercator
 Unit metres
 CM 3°
 Phi 0°
 Scale factor 0.9995
 False Easting 500000
 False Northing 0

SHELL INTERNATIONALE PETROLEUM MAATSCHAPPIJ B.V.		
THE HAGUE	EXPLORATION & PRODUCTION	
RMS AMPLITUDE MAP		
TOP YYYYYYY		
BLOCK X		
Scale 1 : 50 000		
Author: EPX/242	Encl.: 8	Date: August 1993
Report No.: EP 9300000		Draw. No.: H76405P

6.1.3.3 Seismic Stratigraphy

Reflection Terminations

Erosional Truncation and Toplap

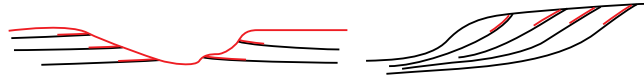

Reflection terminations associated with erosional truncation or toplap should be highlighted with a short, carefully placed red line below the termination. Use a continuous red line to mark the termination surface if associated with a sequence boundary.



Onlap and Downlap



Downlap and onlap should be marked with short, red arrows along the reflections that terminate.



Key Surfaces

Use the colour scheme presented in the Sequence Stratigraphy section (4.4.4) for highlighting sequence boundaries, maximum flooding surfaces, and ravinement/transgressive/flooding surfaces. However, when correlating multiple sequences, it is suggested that different colours be assigned to the maximum flooding surfaces and the sequence boundaries remain highlighted in red or the maximum flooding surfaces are shown in green and different colours are assigned to the sequence boundaries.

	red	Sequence boundary
	green	Maximum flooding surface
	cyan	Ravinement/transgressive/flooding surfaces

System Tracts

Use the colour scheme presented in the Sequence Stratigraphy section (4.4.4) for highlighting systems tracts.











	orange	Highstand systems tract
	light green	Transgressive systems tract
	yellow	Lowstand systems tract

For colours see Appendix 4

Seismic Facies Colour Scheme

There are too many variables and combinations for standardizing seismic facies. However, a colour code is given below for a few general facies that are typically highlighted on seismic sections.







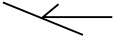

General Reflection Configuration Colour Code

	yellow	Topsets, siliciclastics
	cyan	Foresets, siliciclastics
		Foresets, siliciclastics (optional)
	lawngreen	Bottomsets, siliciclastics (pelagics, hemipelagics)
	dark orange	Debris flows/slumps
	sienna	Levees (submarine channels)
	grey	Incised valley and submarine canyon fill (undifferentiated)
	burlywood	Basin floor fan (e.g. amalgamated channel complex, sheet sands and lobes)
	hotpink	Topsets, carbonates (including lagoonal facies)
	royal blue	Carbonate platform edge (buildups/shoals)
	turquoise	Carbonate slope deposits

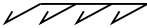
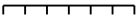
For colours see Appendix 4

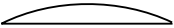
Seismic Facies Symbols on Maps

The following map symbols are suggested:

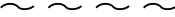
	Onlap		
	Downlap/clinoforms (undifferentiated)		
	Toplapping clinoforms		
	Final offlap break (shelf margin)		
	Channel/canyon morphology		
	Mounded geometries (undifferentiated)		
	sienna	Levee channel	
	royal blue	Carbonate reef	
	red	Volcanic cone	
	dark orange	Retrogressive/rotational slump	
		Chaotic facies	

For colours see Appendix 4

Seismic Facies Notation Scheme

As an alternative to the seismic facies colour scheme, Figure a shows examples of a suggested seismic facies notation scheme and Figure b illustrates the application of the scheme and transferring these observations to a map. The suggested notation scheme can be applied at any scale (individual seismic facies, parasequences, systems tracts, sequences, etc.).

The seismic facies is expressed in the formula below:

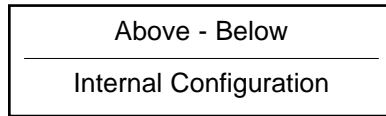

The notations are as follows:

Above

(Top bounding surface)

	Notation
Erosional truncation	Te
Toplap	Tp
Concordance	C

Below

(Bottom bounding surface)

	Notation
Downlap	Dn
Onlap	On
Concordance	C

Internal Configuration

Parallel	P	Sigmoid	S
Subparallel	Sp	Oblique	Ob
Divergent	D	Complex sigmoid-oblique	SO
Chaotic	Ch	Shingled	Sh
Reflection-free	RF	Hummocky clinoforms	HC
Mounded	M	Wavy	W
Prograding clinoforms	PC		

A similar notation scheme can be developed describing amplitude, continuity, and frequency attributes.

Seismic Facies Notation Examples

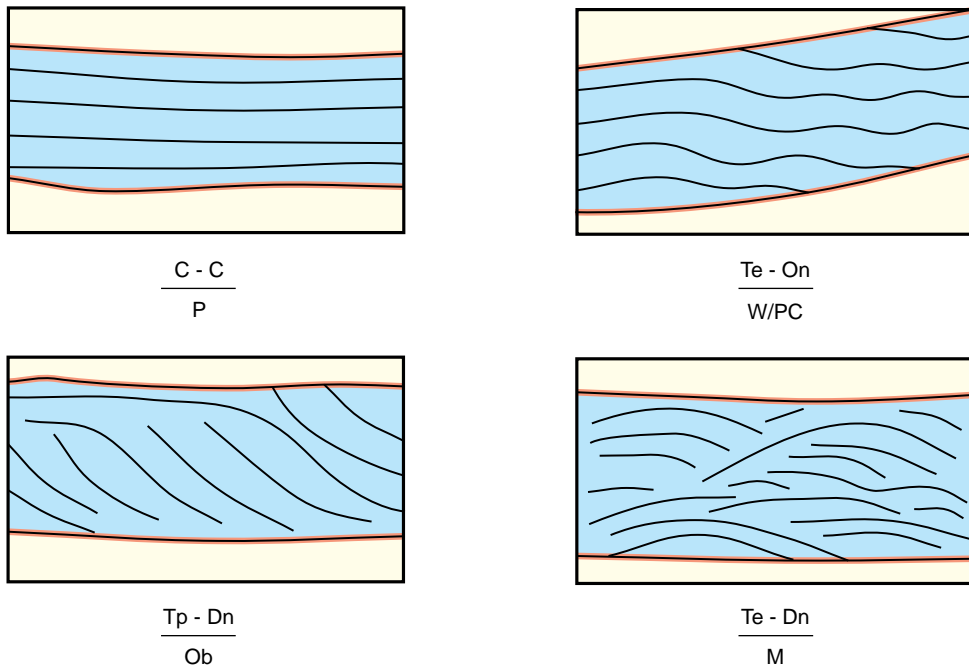
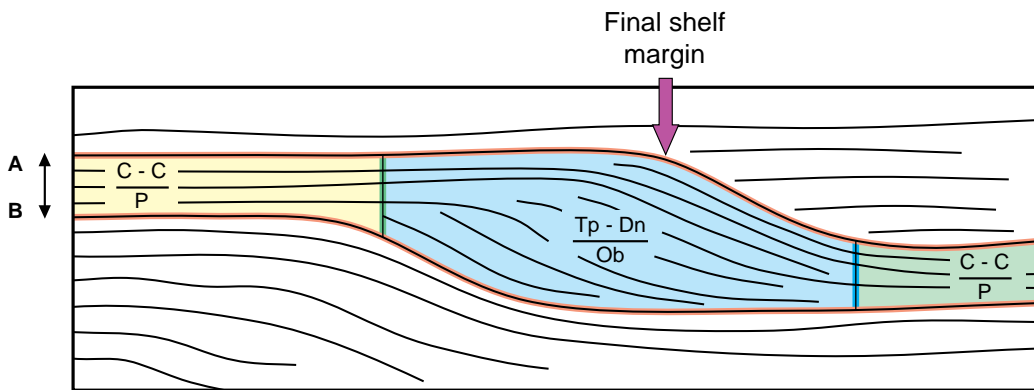
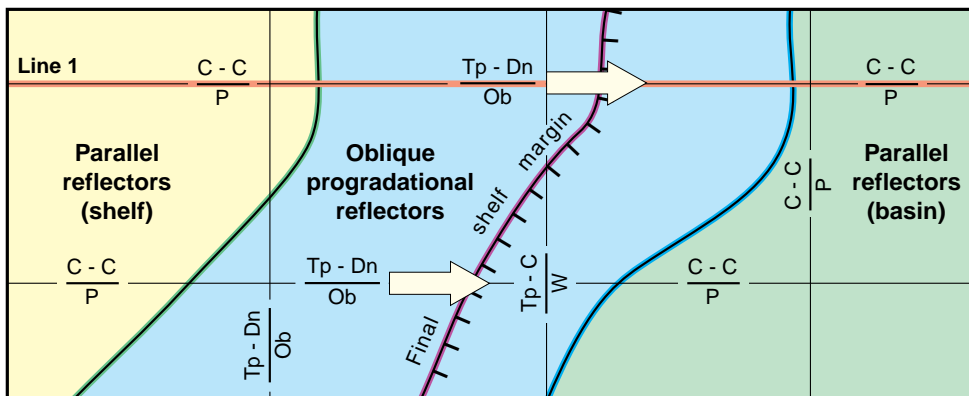

Fig.a

Seismic Facies Mapping



Seismic line 1



Sequence A - B map

Fig.b

6.1.3.4 Seismic Contour Maps

General labelling

- The hydrocarbon, stratigraphical and structural symbol conventions described in Sections 2.1, 4.4 and 4.7 should be followed.
- The nature of the contour map (time, depth, isochrone, etc.) together with units of contours displayed (ms, m, etc.) and scale must be specified in the map title.
- The time-to-depth conversion methodology should be indicated in a side label if appropriate.
- The following items should be indicated on seismic contour maps:
 - the position of the 2D seismic grid (see Section 6.1.1) or the outline of the 3D survey used (subsurface coverage), depending upon the nature of the data set used for correlation purposes.
 - wells and time/depth values of contoured horizons in wells which have penetrated such horizons. The well symbol should be placed at the position where the horizon is penetrated, not the surface location (see Section 2.1.3).

Seismic Uncertainty

The degree of robustness/reliability of the seismic correlation process (horizons and faults) is area dependent and must be shown on time-contoured maps. Depth contour maps should also show the degree of precision achieved with the time-to-depth conversion process, taking into account time correlation uncertainties and the accuracy of the applied velocity field, which is also area dependent. Data fall into three categories of seismic uncertainty:

Category A - Robust Correlation

Faults: Correlated on migrated 3D/2D data sets. Position and lateral displacement known.

Time contour maps: Robust/reliable seismic horizons; two different interpreters would arrive at the same correlation.

Depth contour maps: Within 2% precision.

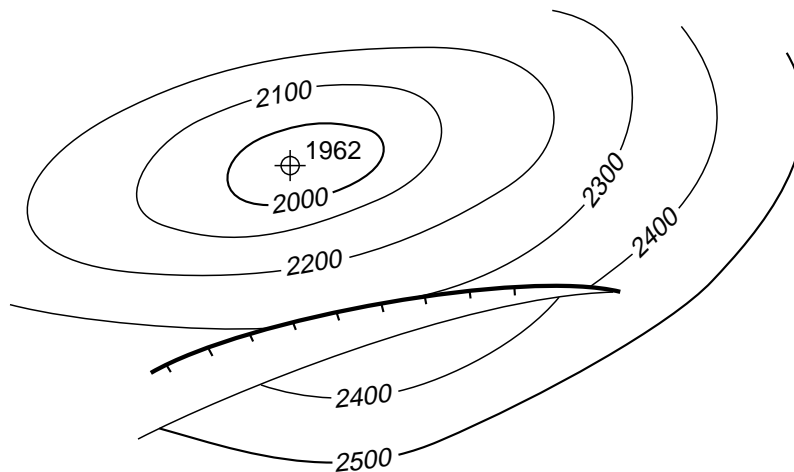

Category B - Weak Correlation

Faults: Correlated on unmigrated seismic data; approximate position and lateral displacement. Question marks to indicate alternative correlations.

Time contour maps: Inferred seismic correlation but error not larger than one seismic loop, i.e. tracking of unconformities/reflection merges/jump correlations across faults.

Depth contour maps: Between 2 and 5 % precision.

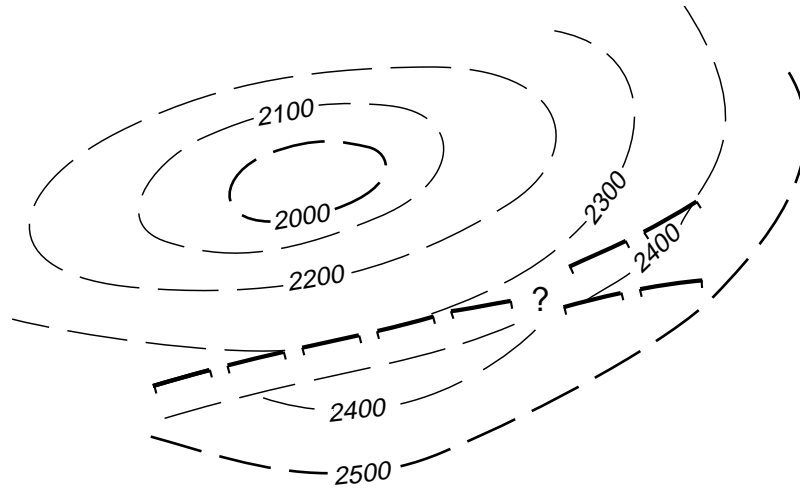

Category C - Inferred Correlation

Faults: Inferred through poor seismic data and/or transcurrent fault zones - thrust zones poorly imaged on seismic; interpretation is questionable; fault intercepts remain largely unknown.

Time contour maps: Likely to be more than one seismic loop in error; correlation is either:

- pushed through seismic noise (based on plausible extrapolation or required for depth conversion purposes, etc.)
- not trusted, correlated events could be seismic artefacts and/or be severely distorted by migration effects.

Depth contour maps: poorer than 5 % precision achieved.

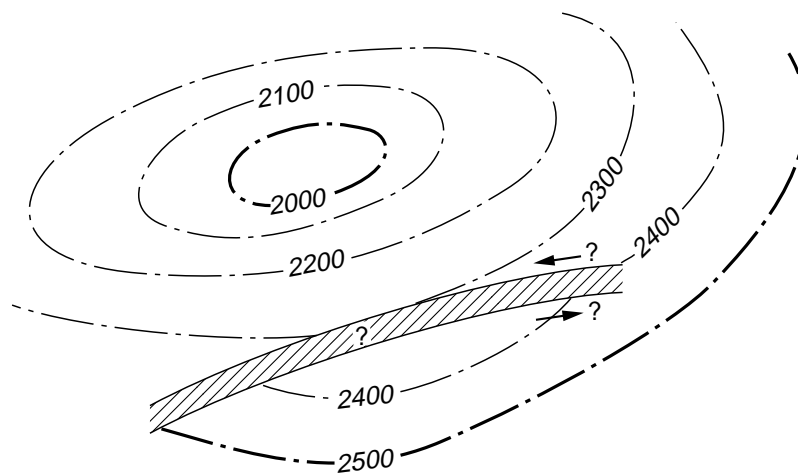

Use of automatic contouring packages and/or Trace Interpretation displays (contoured intervals in colour, etc.) does not remove the need for interpreters to show seismic uncertainty on maps to be used for formal documents (further to the points already stressed under Section 6.1.3). Pending availability of software which allows the display of areal uncertainty, it is suggested to show uncertainty with rasters and/or masks which allow the dimming of colours according to the following scheme:

Category B areas: Light rasters and/or half-dimmed colours

Category C areas: heavy rasters and/or 3/4 dimmed colours

Reflection Termination on Seismic Maps

For showing outcrop and subcrop of a mapped succession of rocks (i.e. on a time or depth isochore/isopach map), reference should be made to the standards of Section 4.4.5.

For seismic horizon maps the following may be used.



Outcrop of contoured horizons



Subcrop of contoured horizons

6.1.4 Well Shoot and Vertical Seismic Profile

On seismic velocity maps, wells in which well shoots have been recorded should be labelled with the appropriate well symbols and the letters WS.

All other borehole seismic surveys should be flagged with the letters VSP (vertical seismic profile). The nomenclature for the differing types of vertical seismic profiles should be as follows:

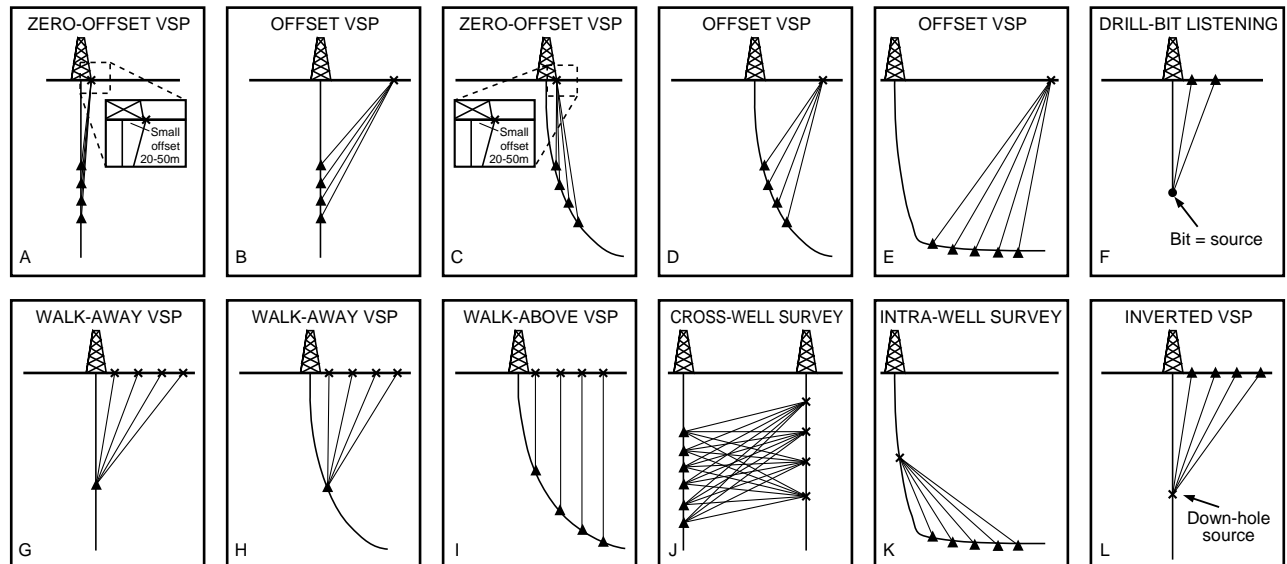

Vertical Seismic Profiling Nomenclature

The well shoot times and vertical seismic profiles should be corrected to the same datum as used for the seismic in the area. The datums should be recorded on the TZ graph/vertical seismic profile. The terminology and abbreviations to be used are as follows:

Schematic Cross-section of Zero-offset VSP Survey

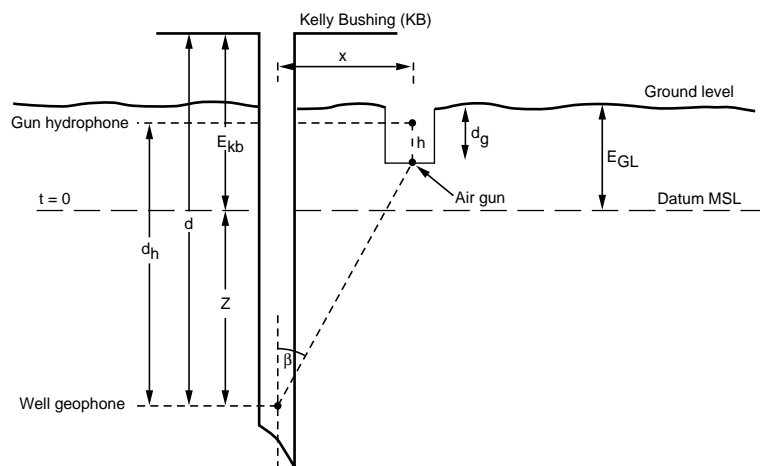

- KB = Kelly Bushing
- d = Depth of well geophone below KB
- E_{kb} = Elevation of KB above datum
- Z = Depth of geophone below datum
- d_g = Depth of gun below Ground Level
- h = Distance between gun and gun hydrophone
- d_h = Depth of well geophone below hydrophone
- t_e = Is that correction which gives zero time at datum
- x = Horizontal distance from well to gun = offset
- β = Incident angle at well geophone levels
- T = Observed travel-time from hydrophone to well geophone
- t = Time corrected to vertical
- t_c = Corrected travel-time to datum ($= t + t_e$)
- Δ_z = Interval distance
- Δ_{t_c} = Interval travel-time
- E_{GL} = Elevation GL above datum
- v = Replacement velocity from hydrophone to datum
- SRD = Seismic reference datum

6.2 Gravity

Gravity Maps

The station control should always be shown.

Gravity Stations on Maps

Land Gravity

- ⊙ Gravity base station
- X Gravity station location

Marine Gravity

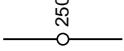
-  Line of gravity observations (usually in conjunction with seismic survey with shotpoint number annotated)

Airborne and Satellite Gravity

- _____ Line of observations

Gravity Contour Data

Free Air Gravity (in mgal) normally used offshore.

Bouguer Gravity (in mgal) normally used onshore (always state correction density).

Regional/residual gravity (in mgal), always give filter applied.

Derivative and upward/downward continued maps, give details.

Contours should be marked with appropriate values, every fifth contour is commonly made bold.

Colour shading of contour maps is common. Two schemes are in common usage:

Positive values	dark red	dark red
	orange	
	yellow	light red
----- 0 -----	-----	
	light green	light blue
	blue-green	
Negative values	dark blue	dark blue

6.3 Magnetics

Magnetic Maps

The magnetic control should always be shown.

Magnetic Control on Maps

Land Magnetics

- ⊙ Magnetic base station (if used for diurnal monitoring)
- X Magnetic station location

Marine Magnetics

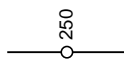
-  Line of magnetic observations (usually in conjunction with seismic survey with shotpoint number annotated)

Airborne Magnetics

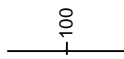
-  Line of observations fiducial points annotated (always give flight height)

Magnetic Contour Data

Total Magnetic Intensity in nT.

Residual Magnetic Intensity (Magnetic anomaly) in nT, state year of IGRF removed.

Derivative and upward/downward continued maps, give details.

Reduced to the pole magnetics, give inclination and declination of RTP operator.

Contours should be marked with appropriate values, every fifth contour is commonly made bold.

Colour shading of contour maps is common. Two schemes are in common usage:

Positive values	dark red	dark red
	orange	
	yellow	light red
----- 0 -----		
Negative values	light green	light blue
	blue-green	
	dark blue	dark blue

Magnetic Interpretation Data

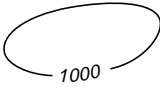
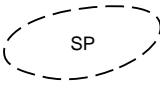
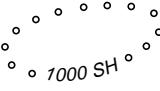
X 2.6	Depth estimate to magnetic basement in kilometres
X 2.6s	Depth estimate based on thin plate assumption attributed to magnetic basement
X 2.6sh	Depth estimate to interpreted inter-sedimentary anomaly
	Magnetic lineament
	Depth contour to magnetic basement
	Outline of supra-basement anomaly (thin body at basement level)
	Depth contour to inter-sedimentary magnetic disturbance

REFERENCES

- Archie, G.E. (1952) Classification of carbonate reservoir rocks and petrophysical considerations. AAPG Bull., **36**, 278-298.
- Bates, R.C. & Jackson, J.A. (eds.) (1987) Glossary of Geology, Third Edition. American Geological Institute, Alexandria, Virginia, 788 pp.
- Dunham, R.J. (1962) Classification of carbonate rocks according to depositional texture. In Ham, W.E. (ed.), Classification of Carbonate Rocks, AAPG Mem.1, 108 - 121.
- Embry, A.F. & Klovan, J.E. (1971) A late Devonian reef tract on Northeastern Banks Island, Northwest Territories. Bull. Can. Petrol. Geol., **19** (4), 730-781.
- Goddard, E.N., Trask, P.D. *et al.* (1963) Rock-Color Chart. Geol. Soc. America Spec. Paper.
- Haq, B.U., Hardenbol, J. & Vail, P.R. (1988) Mesozoic and Cenozoic chronostratigraphy and cycles of sea-level change. In: Wilgus, C.K. *et al.* (eds.), Sea-Level Changes: An Integrated Approach, SEPM Spec. Publ. No. 42, 71-108.
- Harland, W.B., Armstrong, R.L., Cox, A.V., Craig, L.E., Smith, A.G. & Smith, D.G. (1990) A geologic time scale 1989. Cambridge University Press, Cambridge, 263 pp.
- Pettijohn, F.J., Potter, P.E. & Siever, R. (1987) Sand and Sandstone, 2nd edition. Springer Verlag, New York, 553 pp.
- Salvador, A. (ed., 2nd edition) (1994) International Stratigraphic Guide - A Guide to Stratigraphic Classification, Terminology, and Procedure. The Geological Society of America, 214 pp.
- Streckeisen, A. (1976) To each plutonic rock its proper name. Earth Science Rev., **12**, 1-33.
- Swanson, R.G. (1981) Sample Examination Manual. AAPG Methods in Exploration Series.
- Visser, W.A. (ed.) (1980) Geological Nomenclature. Royal Geol. Min. Soc. Netherlands, Bohn, Scheltema & Holkema, Utrecht; Marinus Nijhoff, The Hague, Boston, London, 540 pp.
- Wentworth, C.K. (1922) A scale of grade and class terms for clastic sediments. J. Geol., **30**, 377- 392.
- Ziegler, P.A. (1982) Geological Atlas of Western and Central Europe. Elsevier Sci. Publ., Amsterdam, 130 pp. and 40 pl.
- Ziegler, P.A. (1989) Evolution of Laurussia - A Study in Late Palaeozoic Plate Tectonics. Kluwer Academic Publishers Dordrecht/Boston/London, 102 pp. and 14 pl.
- Ziegler, P.A. (1990) Geological Atlas of Western and Central Europe, second and completely revised edition. SIPM, The Hague, 238 pp. and 56 pl.

ALPHABETICAL INDEX

Subject	Abbreviation	Section
A		
Abbreviations, alphabetical listing		At the end
Abbreviations, rules		1.1
abyssal	ABL	4.5.1.1
Acetone	Acet	2.2.8.5
Acetone reaction		2.3
Acid-frac	AF	2.2.5
Acid treatment	AT	2.2.5
Acritarchs	Acrt	4.3.5.2
Agglomerate	Ag, vo	4.2.8.3
Aggrading parasequence set	APS	4.4.4
Air lift	AL	2.2.6
Algae	Alg	4.3.5.2
Algal domes	Alg Dom	4.3.5.4
Algal mats	Alg Mat	4.3.5.4
Alkali feldspars	A	4.2.8.1
Alkaline rocks		4.2.8.1
alluvial		4.5.2
Along hole	AH	2.1.3
Along hole depth	AHD	1.3.3; App. 5
Alphabetical index		At the end
Ammonites	Amm	4.3.5.2
amorphous	amor	4.3.6.4
Amphibolite	Am	4.2.9
Andesite	An	4.2.8.3
angular	ang	4.3.1.3
angular, sub-	(ang)	4.3.1.3
angular, very	<u>ang</u>	4.3.1.3
Anhydrite	Anhd	4.2.5; 4.3.4
Anhydrite, chicken-wire		4.3.7.3
Anhydrite, colour symbol		4.2.10
Animal tubes	Bor	4.3.5.3
Anorthosite	Ao	4.2.8.1
Anthracite	Anthr	4.2.6
Anticlines		4.7.3
aphanitic	aph	4.2.3.1
Aphanitic mudstone	A	4.2.3.1
Archie classification		4.3.2.6
Archie porosity types		4.3.2.7
Arenite		4.3.1.1; 4.3.1.10
argillaceous	arg	4.2.2.2
Argillaceous limestone	Lst, arg	4.2.4
Arkose	Ark	4.2.2.2; 4.3.1.10
Arkosic arenite		4.3.1.10
B		
Backreef		4.5.2
Bafflestone		4.2.3.1
bailed	Bl	2.2.6
Ball-and-flow structure		4.3.7.2
Barrel(s)	B, b	2.2.6
Barrel(s) of oil	BO	2.2.6
Barrel(s) of water	BW	2.2.6
Basalt	Ba	4.2.8.3
Base of bed		4.3.6.3
Base of bed, abrupt		4.3.6.3
Base of bed, gradational		4.3.6.3
Basin floor fan complex	BFF	4.4.4
bathyal	BAT	4.5.1.1; 4.5.1.2
bathyal, lower	LBAT	4.5.1.1; 4.5.1.2

bathyal, middle	MBAT	4.5.1.1; 4.5.1.2
bathyal, upper	UBAT	4.5.1.1; 4.5.1.2
Bathymetric contours		3.7
Beam pump	BP	2.1.2.3
Bed	Bd	4.4.1.1
Bed thickness		4.3.6.1
bedded	bd	4.3.6.2
bedded, centimetre	cm-bd	4.3.6.1
bedded, decimetre	dm-bd	4.3.6.1
bedded, fairly well	bd	4.3.6.2
bedded, metre	m-bd	4.3.6.1
bedded, millimetre	mm-bd	4.3.6.1
bedded, slightly (poorly)	(bd)	4.3.6.2
bedded, thick	tk-bd	4.3.6.1
bedded, thin	tn-bd	4.3.6.1
bedded, variable	vr-bd	4.3.6.1
bedded, very well	<u>bd</u>	4.3.6.2
bedded, well	<u>bd</u>	4.3.6.2
Bedding appearance		4.3.6.2
Bedding appearance, miscellaneous terms		4.3.6.4
Bedding, contorted	cont-bd	4.3.6.12
Bedding, convolute	conv-bd	4.3.6.12
Bedding, entherolithic		4.3.6.12
Bedding, graded	grd-bd	4.3.6.10
Bedding, irregular wavy	irg-bd	4.3.6.9
Bedding, linsen		4.3.6.9
Bedding, massive	mass, unbd	4.3.6.2
Bedding, slumped	slump	4.3.6.12
Bedding, strike and dip		4.7.4.1
Belemnites	Blm	4.3.5.2
below derrick (drilling) floor	bdf	App. 5
Bentonite cement	BC	2.2.3
Bindstone		4.2.3.1
biogenic, bacterial (gas)	B	2.2.8.1
Bioherm		4.3.6.5
Biostratigraphical charts, depositional environment		4.5.1
Biostratigraphy		4.4.2
Biostrome		4.3.6.5
Biotite	Biot	4.3.4
bioturbated		4.3.5.3
Biozone/biozonation		4.4.2.1
Birdseye structure		4.3.7.2
Bischofite	Bi	4.2.5
Bitumen shows	T	2.1.2.2
bituminous	bit	4.2.6
Bituminous coal	C, bit	4.2.6
Bivalves	Biv	4.3.5.2
black	blk	4.3.3.1
blocky	blky	4.3.6.4
blue	blu	4.3.3.1
Boghead	C, sapropel	4.2.6
Bored surface	Srf, bor	4.3.5.3
Borehole Compensated Sonic Log	BHC	1.3.2
Borehole Televiewer	BHTV	1.3.2
Borings	Bor	4.3.5.3
Bottom hole pressure	BHP	2.2.6
Bottom hole temperature	BHT	1.3.3
Boudinage		4.3.7.2
Boulder	Bld	4.3.1.1
Bounce casts		4.3.6.13
Boundaries, topography		3.3
Boundaries, stratigraphical		4.4.5
Boxwork structure		4.3.7.2
Brachiopods	Brac	4.3.5.2

Breccia	Brc	4.2.2.2
Breccia, colour symbol		4.2.10
Bridge plug	BP	2.2.3
brown	brn	4.3.3.1
Brown coal	Lig	4.2.6
Bryozoa	Bry	4.3.5.2
buff	buf	4.3.3.1
Burial graph		5.2.2
Burrows, vertical or horizontal	Bur	4.3.5.3
C		
calcareous	calc	4.2.3.2
Calcispheres	Calsph	4.3.5.2
Calcite	Calc	4.3.4
Caliche		4.3.7.1
Caliper	CAL	1.3.2
Cannel coal	C, sapropel	4.2.6
Caprock	CR	2.1.2.6
carbonaceous	c	4.2.6
Carbonaceous drape		4.3.6.13
Carbonate classification, Dunham		4.2.3.1
Carbonate facies, terminology		4.5.3.2
Carbonate lithotypes		4.2.3.2
Carbonate slope		4.5.2
Carbonates		4.2.3
Carnallite	Cn	4.2.5
Casing	C, Csg	2.1.2.5; 2.2.3
Casing accessories, engineering symbols		2.2.3
Cementations		2.2.3
Cement Bond Log	CBL	1.3.2
cemented	cmt	4.3.7.1
cemented through perforations	CP	2.2.3
cemented, strongly (highly)	<u>cmt_cons</u>	4.3.7.1
Cement retainer	CR	2.2.3
Centralizer(s)	C	2.2.3
Chalk	Chk	4.2.3.2
Chalk, colour symbol		4.2.10
Charophytes	Char	4.3.5.2
Chert	Cht	4.2.7
Chitinozoa	Chtz	4.3.5.2
Chronostratigraphical units, alphabetical		App. 2
Chronostratigraphical units, abbreviations, alphabetical		App. 3
Chronostratigraphical units, ordered by age		App. 1
Chronostratigraphy		4.4.3
churned		4.3.5.3
Classification, Archie		4.3.2.6
Classification, compositional of siliciclastics		4.3.1.10
Classification, Dunham		4.2.3.1
Classification, kerogen types		5.1.2.2
Classification, reef limestones		4.2.3.1
Clastic facies, terminology		4.5.3.1
Clay	Cl	4.2.2.2
Clay drape		4.3.6.13
Clay, colour symbol		4.2.10
Claystone	Clst	4.2.2.2; 4.3.1.10
Claystone, colour symbol		4.2.10
Cleavage		4.7.4.2
Climbing ripples	xbd-r	4.3.6.6
Closure, non-structural		4.7.7.2
Closure, structural		4.7.7.1
Closures on play, lead and prospect maps		4.7.7
Coal	C	4.2.6
Coal conglomerate	CCgl	4.2.6
Coal, colour symbol		4.2.10

Coal, composition		4.2.6
Coal, rank classification		4.2.6
coarse	crs	4.3.1.1
coastal		4.5.1.2
coastal, fluviomarine	COF	4.5.1.1
coastal, holomarine	COL	4.5.1.1
Coastal plain	CP	4.5.1.1; 4.5.2
Coastal plain, lower	LCP	4.5.1.1
Coastal plain, upper	UCP	4.5.1.1
Coated grains		4.3.1.8
Cobble	Cbl	4.3.1.1
Coiled tubing	CTB	2.1.2.7; 2.2.1
Collapse breccia		4.3.7.2
Colour coding, depositional environments		4.5.1.2; 4.5.2
Colour description		4.3.3
Colour symbols, lithology		4.2.10
Colours		4.3.3.1
Colours, modifying adjectives		4.3.3.2
Colours, names and RGB/CMYK values		App. 4
compacted	<u>cmp</u>	4.3.1.5
compacted, slightly	(cmp)	4.3.1.5
compacted, strongly	cmp	4.3.1.5
Compaction		4.3.1.5
Compensated Densilog	CDL	1.3.2
Compensated Neutron Log	CNL	1.3.2
Completion	Comp	2.2.1
Completion liner symbols		2.2.4
Completion log		1.3.3
Completion methods		2.2.4
Completion packer symbols		2.2.4
Completion status, well		2.1.2.5
Complex	Cx	4.4.1.1
Composite log		1.3.3
conchoidal	conch	4.3.6.4
Concretions	Conc	4.3.7.3
Concretions, anhydrite	anhd-Conc	4.3.7.3
Concretions, calcareous	calc-Conc	4.3.7.3
Concretions, ferruginous	fe-Conc	4.3.7.3
Concretions, phosphatic	phos-Conc	4.3.7.3
Concretions, siderite	sid-Conc	4.3.7.3
Concretions, siliceous	si-Conc	4.3.7.3
Condensate	C	2.2.6
Condensate fields on maps		2.4
Condensation horizons	CST	4.4.4
Condensed systems tract	CST	4.4.4
Cone-in-cone		4.3.7.2
Conglomerate	Cgl	4.2.2.2
Conglomerate, colour symbol		4.2.10
Conodonts	Con	4.3.5.2
Conservation (of productive well)	C	2.1.2.3
consolidated	cons	4.3.7.1
consolidated, slightly	(cons)	4.3.7.1
Contact, erosional		4.3.6.3
continental	CONT	4.5.1.1; 4.5.1.2; 4.5.2
Continuous Sample Taker	CST	1.3.2
Contour maps, seismic		6.1.3.4
Coprolite		4.3.1.8
Corals	Cor	4.3.5.2
Core	C	2.1.2.2; 2.2.2; 2.2.8.1; 2.2.8.5
Core hole	CH	2.1.2.7
Coring after drilling	CAD	2.2.2
Crinoids	Crin	4.3.5.2
Cross-bedding	xbd	4.3.6.6

Cross-bedding, angle indicated		4.3.6.6
Cross-bedding, chevron type	xbd-c	4.3.6.6
Cross-bedding, directional		4.3.6.6
Cross-bedding, festoon	xbd-f	4.3.6.6
Cross-bedding, herringbone type	xbd-c	4.3.6.6
Cross-bedding, non-directional	xbd	4.3.6.6
Cross-bedding, planar	xbd-p	4.3.6.6
Cross-bedding, tabular	xbd-tb	4.3.6.6
Cross-bedding, trough	xbd-tr	4.3.6.6
Cross-sections, structural		4.7.5
Cross-stratification, hummocky	xbd-hm	4.3.6.6
Cross-stratification, swaley	xbd-s	4.3.6.6
Crystal	XI	4.3.4
Crystal ghosts		4.3.7.2
crystalline	xln	4.2.3.1
Cuttings	Ctg	2.1.2.2; 2.2.8.1; 2.2.8.5

D

Daily rate	DR	2.2.6
dark	dk	4.3.3.2
Debris flows/slumps	DF	4.4.4
Deep water fan system	DWF	4.4.4
Delta tectonics, trap styles		4.7.6.2
dense	nonpor	4.3.2.4
Density	DEN	1.3.2
Depositional environments		4.5
Depositional environments, biostrat. charts, abbreviations		4.5.1.1
Depositional environments, biostrat. charts, colour coding		4.5.1.2
Depositional environments, facies terminology		4.5.3
Depositional environments, facies terminology, carbonates		4.5.3.2
Depositional environments, facies terminology, clastics		4.5.3.1
Depositional environments, maps/sections, colour coding		4.5.2
Depositional lower edge		4.4.5.2
Depositional upper edge		4.4.5.2
Derrick (drilling) floor elevation	ELEV	1.3.1; 1.3.3; App.5
Deviated holes		2.1.3
Diabase	Db	4.2.8.2
Diagenetic structures		4.3.7.2
Diamictite	Tilt	4.2.2.2
Diamictite, colour symbol		4.2.10
Diatoms	Diat	4.3.5.2
Dinoflagellates	Dinfl	4.3.5.2
Diorite	Dr	4.2.8.1
Dioritoids		4.2.8.1
Dip closure		4.7.6.1
Dip data		2.2.2
Dip symbols on sections		4.7.5
Dip symbols on surface geological maps		4.7.4
Disconformity	D	4.4.1.2; 4.4.5.1
Dish (and pillar) structure		4.3.6.12
Distribution charts, quantity symbols		4.4.2.3
disturbed		4.3.7.1
Dolerite	Do	4.2.8.2; 4.2.8.3
Dolomite	Dol	4.2.3.2; 4.3.4
Dolomite, colour symbol		4.2.10
Dolomite-limestone, equal mixture	Dol-Lst	4.2.3.2
dolomitic	dol	4.2.3.2
Dolomitic limestone	Lst, dol	4.2.3.2
Drag folds (sedimentary)	Drgfld, sed	4.3.6.12
Drilling	Drill	2.2.1
Drilling data		2.2.1
Drilling fluid loss		2.2.1
Drilling fluid type		2.2.1

Drillstem test	DST	2.1.2.2; 2.2.6; 2.2.8.1
driven (casing)	Dr	2.2.3
Dual Laterolog	DLL	1.3.2
Dunham classification		4.2.3.1
Dyke	Dy	4.2.8.2
Dyke, sedimentary	Dyke	4.3.6.12
E		
Early; early	Ey; ey	4.4.3
Echinoderms	Ech	4.3.5.2
Electrical logs	EL	2.2.8.1
Electrical log displays		1.3.2
Electrical submersible pump	ER; ESP	2.1.2.3; 2.2.4
Elevation contours		3.6
Elevation reference level	ELEV	1.3.1; 1.3.3; App. 5
elongated	elong	4.3.1.4
elongated, slightly	(elong)	4.3.1.4
elongated, very	<u>elong</u>	4.3.1.4
Environmental maps		3.5.4
Erosional lower edge		4.4.5.2
Erosional upper edge		4.4.5.2
Evaporites		4.2.5
Extrusive rocks	Ex	4.2.8.3
F		
Facies terminology		4.5.3
Facies terminology, carbonate facies		4.5.3.2
Facies terminology, clastic facies		4.5.3.1
Facilities	Fac	2.1.2.3
Faecal pellet	Pel, fae	4.3.1.8
Fault closure		4.7.6.1
Fault, columnar sections	F	4.4.6.1
Fault, normal, columnar sections	FN	4.4.6.1
Fault, reverse, columnar sections	FR	4.4.6.1
Fault, thrust, columnar sections	FT	4.4.6.1
Fault reliability and heave		4.7.2.3
Fault terminology		4.7.1
Fault types, symbols		4.7.2.1
Fault-contour relationships		4.7.2.5
faulted	flt	4.3.7.1
faulted out	f	2.1.2.6
Faulting, gap due to		4.4.6.1
Faults on surface geological and horizon maps		4.7.2
Faults, general aspects		4.7.1
Faults, measures of separation		4.7.1
Faults, measures of slip		4.7.1
Faults, re-activated		4.7.2.2
Feldspar	Fld	4.2.2.1; 4.3.4
Feldspathic wacke		4.3.1.10
Feldspathoids	F	4.2.8.1
Fenestral structure		4.3.7.2
ferruginous	fe	4.2.7
Final flowing bottom hole pressure	FFBHP	2.2.6
Final flowing surface pressure	FFSP	2.2.6
Final shut in bottom hole pressure	FSIBHP	2.2.6
fine	f	4.3.1.1
Fish remains	Fish Rem	4.3.5.2
Fish scales	Fish Sc	4.3.5.2
fissile	fis	4.3.6.4
flaky	flk	4.3.6.4
Flame structure		4.3.6.12
Flexures		4.7.3
Floatstone		4.2.3.1

Flooding surface	FS	4.4.4
Floored cavities		4.3.6.13
flowed	F	2.2.6
Fluid level	FL	2.2.6
Fluid lift	FL	2.1.2.3
Fluid sampling		2.2.6
Fluorescence	Flu	2.2.8.5; 2.3
Flute casts	flut-Cs	4.3.6.13
fluviomarine, inner neritic	FIN	4.5.1.1
fluviomarine, middle neritic	FMN	4.5.1.1
fluviomarine, outer neritic	FON	4.5.1.1
Foids	F	4.2.8.1
Fold, ptygmatic		4.3.6.12
Folds		4.7.3
Folds, minor		4.7.4.2
Foliation		4.7.4.2
Foraminifera	Foram	4.3.5.2
Foraminifera, larger	Foram, lg	4.3.5.2
Foraminifera, larger, coated		4.3.1.9
Foraminifera, pelagic	Foram, pelg	4.3.5.2
Foraminifera, pelagic, broken		4.3.1.9
Foraminifera, planktonic	Foram, plk	4.3.5.2
Foraminifera, smaller	Foram, sm	4.3.5.2
Foraminifera, smaller, benthonic	Foram, sm, bnt	4.3.5.2
Forced regressive shoreface wedge	FRW	4.4.4
Fore-reef		4.5.2
Formation	Fm	4.4.1.1
Formation Density Log	FDC	1.3.2
Formation dip		2.1.2.6
Formation fluid sampling		2.2.6
Formation Interval Tester	FIT	1.3.2
Formation lithological sampling		2.2.2
Formation MicroImager	FMI	1.3.2
Formation MicroScanner Log	FMS	1.3.2
Formation pressure		2.2.6
Formation treatment		2.2.5
Formation waters		2.2.8.4
Formation, unknown		4.4.6.1
Fossil ghosts		4.3.7.2
Fossils	Foss	4.3.5; 4.3.5.1
Fossils, benthonic	Foss, bent	4.3.5.1
Fossils, brackish water	Foss, brack	4.3.5.1
Fossils, fresh water	Foss, fresh	4.3.5.1
Fossils, marine	Foss, mar	4.3.5.1
Fossils, pelagic	Foss, pelg	4.3.5.1
Fossils, specific		4.3.5.2
Fossils, unspecified	Foss	4.3.1.9
Fossils, unspecified, broken, angular	Bcl, ang	4.3.1.9
Fossils, unspecified, broken, rounded	Bcl, rnd	4.3.1.9
fractured	frac	4.3.7.1
Fracturing (of reservoir)	FRAC	2.2.5
Fragment, angular	Lcl	4.3.1.6
Framestone		4.2.3.1
Free water level	FWL	2.4
friable	fri	4.3.1.5; 4.3.7.1
G		
Gabbro	Gb	4.2.8.1
Gabbroids		4.2.8.1
Gamma Ray	GAM	1.3.2
Gamma Ray Log	GR	1.3.2
Gamma Ray Spectroscopy Log	GST	1.3.2
Gap, due to faulting		4.4.6.1
Gap, erosional		4.4.6.1

Gap, stratigraphical		4.4.6
Gaps on layer maps		4.4.6.2
Gas	G	2.2.6
Gas and oil cut mud	GOCM	2.2.6
Gas-condensate fields on maps		2.4
Gas/condensate producer	GCP	2.1.2.3
Gas/condensate ratio	GCR	2.2.6
Gas cut mud	GCM	2.2.6
Gas down to	GDT	2.4
Gas (dry/wet) fields (incl. pre/post-production) on maps		2.4
Gas fields with oil rim on maps		2.4
Gas injector	GI	2.1.2.3
Gas lift	GL	2.1.2.3; 2.2.6
Gas/liquid contact	GLC	2.4
Gas/oil contact	GOC	2.4
Gas/oil ratio	GOR	2.1.2.3; 2.2.6
Gas on subsurface maps and sections		2.4
Gas producer	GP	2.1.2.3
Gas shows on maps		2.5.1
Gas source rock		5.1.1
Gas to surface	GTS	2.2.6
Gas up to	GUT	2.4
Gas/water contact	GWC	2.4
Gas, well bore symbols		2.2.8.1
Gastropods	Gast	4.3.5.2
General drilling data		2.2.1
Geochemistry		5.0
Geochronology		4.4.3
Geodes		4.3.7.3
Geological High Resolution Magnetic Tool	GHMT	1.3.2
Geological/structural well information		2.1.2.6
Geology		4.0
Geopetal fabric		4.3.6.13
Geophysics		6.0
Glauconite	Glc	4.2.7; 4.3.4
Gneiss	Gns	4.2.9
Graded bedding	grd-bd	4.3.6.10
Graded bedding, fining upward		4.3.6.10
Graded bedding, inverse, coarsening upward		4.3.6.10
Graded beds	grd-bd	4.3.6.10
Grain size		4.3.1.1
Grains NaCl per gallon	GCG	2.2.6
Granite	Gr	4.2.8.1
Granitoids and related rocks		4.2.8.1
Granodiorite	Grdr	4.2.8.1
Granule	Gran	4.3.1.1
Grapestone	Gpst	4.3.1.6
Graptolites	Grap	4.3.5.2
Gravel	Grv	4.2.2.2
Gravel, colour symbol		4.2.10
Gravel pack(ed)	GP	2.1.2.5; 2.2.4
Gravity		6.2
Gravity contour data		6.2
Gravity stations		6.2
green	gn	4.3.3.1
grey	gy	4.3.3.1
Greywacke	Gwke	4.2.2.2
Groove casts	grov-Cs	4.3.6.13
Ground level	GL	1.3.1; 1.3.3; App.5
Group	Gp	4.4.1.1
Gypsum	Gyp	4.2.5; 4.3.4
Gypsum, colour symbol		4.2.10

H

Halite		4.2.5
hard	hd	4.3.1.5; 4.3.7.1
Hard coal	C, hd	4.2.6
Heavily oil cut mud	HOCM	2.2.6
Hiatus	Hi	4.4.1.2; 4.4.5.1
Hiatus, non-deposition		4.4.6.1
High Resolution Dipmeter Log	HDT	1.3.2
Highstand systems tract	HST	4.4.4
Hole full of salt water	HFW	2.2.8.4
holomarine, inner neritic	HIN	4.5.1.1
holomarine, middle neritic	HMN	4.5.1.1
holomarine, outer neritic	HON	4.5.1.1
Horizon contours		4.7.2.4
Horizontal holes		2.1.4
Hornblende	Hrb	4.3.4
Horse-tailing		4.3.7.2
Humic coal	C, humic	4.2.6
Hydraulic pump	HP	2.1.2.3
Hydrocarbon(s)	HC	2.2.2
Hydrocarbon fields and prospects on maps/sections, colour coding		2.4
Hydrocarbon show reporting/indications		2.3
Hydrocarbon status, well		2.1.2.2
Hydrocarbons down to	HDT	2.4
Hydrocarbons, gases and waters, well bore symbols		2.2.8
Hydrocarbons up to	HUT	2.4
Hydrostatic pressure	HP	2.2.6

I

Ichnofossils		4.3.5.3
Igneous rocks		4.2.8
Ignimbrite	Tf, weld	4.2.8.3
Illite	Ill	4.3.4
impermeable	imper	4.3.2.5
Imprints, raindrop	rain-imp	4.3.6.13
Incised valley fill	IVF	4.4.4
Induction Logging	IL	1.3.2
indurated	ind	4.3.1.5
Initial flowing bottom hole pressure	IFBHP	2.2.6
Initial flowing surface pressure	IFSP	2.2.6
Initial shut in bottom hole pressure	ISIBHP	2.2.6
Injection status, well		2.1.2.4
Intermittent lift	IPL	2.1.2.3
Intrusive rocks	In	4.2.8.1
Invalid test	IV	2.1.2.6
Inversion tectonics, trap styles		4.7.6.2
Invert oil emulsion mud	IOEM	2.2.1
Ironstone	Fest	4.2.7
Isochore		App. 6
Isopach		App. 6
Isopach map, annotated		4.4.6.2

J

Jacket		2.1.1
Jet pump	JP	2.1.2.3
jointed	jt	4.3.7.1
jointed, horizontal	jt h	4.3.7.1
jointed, vertical	jt v	4.3.7.1
Jointing		4.7.4.2

K

Kainite	Ka	4.2.5
Kaolinite	Kao	4.3.4
Keystone vugs		4.3.7.2

Kieserite	Ki	4.2.5
L		
Lag		4.3.6.10
Lagoon		4.5.2
Lamellibranchs	Lbr	4.3.5.2
Lamellibranchs, pelagic	Lbr, pelg	4.3.5.2
laminated	lam	4.3.6.4
Lamination, horizontal		4.3.6.8
Lamination, non-parallel		4.3.6.8
Lamination, parallel		4.3.6.8
landed (casing)	L	2.2.3
Larger foraminifera, coated		4.3.1.9
Late; late	Lt; It	4.4.3
Laterolog	LL	1.3.2
Layer	Lyr	4.4.1.1
Layer, lenticular	Len	4.3.6.5
Layer maps, gaps on		4.4.6.2
Layer, wedge-shaped	Wdg	4.3.6.5
leached	leach	4.3.7.1
Leads on maps		2.4
Lens	Len	4.3.6.5; 4.4.1.1
Lens, concave bottom, flat top		4.3.6.5
Lens, flat bottom, convex top		4.3.6.5
Lentil	Len	4.4.1.1
Leveed channel complex	LCC	4.4.4
light	It	4.3.3.2
Lignite	Lig	4.2.6
Lime boundstone	Bdst, B	4.2.3.1
Lime grainstone	Grst, G	4.2.3.1
Lime mud, unconsolidated	L mud, uncons	4.2.3.2
Lime mudstone	Mdst, M	4.2.3.1
Lime mudstone, aphanitic	A	4.2.3.1
Lime packstone	Pkst, P	4.2.3.1
Lime wackestone	Wkst, W	4.2.3.1
Limestone	Lst	4.2.3.2
Limestone, argillaceous	Lst, arg	4.2.4
Limestone, colour symbol		4.2.10
Limestone, sandy	Lst, s	4.2.4
Limonite	Lmn	4.3.4
Lineation		4.7.4.2
Lineation, fossil	foss-Lin	4.3.6.11
Lineation, parting	part-Lin	4.3.6.11
Lineation, pebble	pbl-Lin	4.3.6.11
Lineation, plant fragment	plt-Lin	4.3.6.11
Lineation, primary current		4.3.6.11
Lineation, sand grain	grain-Lin	4.3.6.11
Lineation, shell	foss-Lin	4.3.6.11
Lineation, streaming	strm-Lin	4.3.6.11
Lineations on bedding planes		4.3.6.11
Liner	L	2.1.2.5; 2.2.3
Liner accessories, engineering symbols		2.2.3
Liner hanger	H	2.2.4
Liner, top of	TOL	2.2.3
Litharenite		4.3.1.10
Lithic arkose		4.3.1.10
Lithic wacke		4.3.1.10
Lithoclast	Lcl	4.2.2.1; 4.3.1.6
Lithoclasts, aggregated	Lcl, aggr	4.3.1.6
Litho Density Log	LDL	1.3.2
Lithological colour symbols		4.2.10
Lithology		4.2
Lithology, order of description		4.2.1
Lithostratigraphical gaps		4.4.1.2

Lithostratigraphical terminology		4.4.1.1
Lithostratigraphy		4.4.1
Load cast	load-Cs	4.3.6.12
Location map, seismic		6.1.1
Location (well)		2.1.1
Log	L	2.1.2.2
loose	lse	4.3.7.1
Lower; lower	L; l	4.4.1.1; 4.4.3
Lowstand systems tract	LST	4.4.4
Lowstand wedge	LW	4.4.4
Lutite		4.3.1.1
M		
Mafic minerals	M	4.2.8.1
Magnesium salts		4.2.5
Magnetic contour data		6.3
Magnetic control on maps		6.3
Magnetic interpretation data		6.3
Magnetics		6.3
Marble	Marb	4.2.9
marine, deep		4.5.2
marine, shallow		4.5.2
marine, transitional		4.5.1.2
Marks, syndepositional		4.3.6.13
Marl	Mrl	4.2.4
Marl, colour symbol		4.2.10
Marlstone	Mrlst	4.2.4
Mass flow	Olistr	4.3.6.5
Matrix texture		4.3.2.6
Maturity vs. depth graph		5.2.3
Maturity zones		5.2.1
Maximum flooding surface	MFS	4.4.4
Mean sea-level	MSL	App. 5
Mechanical Sidewall Coring Tool	MSCT	1.3.2
medium	m	4.3.1.1
medium (colour)	mod	4.3.3.2
Member	Mbr	4.4.1.1
Metamorphic rocks	Metam	4.2.9
Metamorphic rocks, colour symbol		4.2.10
Mica	Mic	4.3.4
Mica-schist	Sch, mic	4.2.9
Micro Laterolog	MLL	1.3.2
Micropelletoid	Micrpeld	4.3.1.8
Microplankton	Mpl	4.3.5.2
Microspherically Focused Resistivity Log	MSFL	1.3.2
Mid; mid	M; m	4.4.3
Middle; middle	M; m	4.4.1.1; 4.4.3
Migmatite	Migm	4.2.9
Million years	Ma	4.4.3
Minerals, abbreviations		4.3.4
Minerals, accessory		4.3.4
Mixed siliciclastics-carbonates		4.2.4
moderate	mod	4.3.3.2
Modified cement	MC	2.2.3
Molluscs	Mol	4.3.5.2
Montmorillonite	Mtmo	4.3.4
mottled	mtl	4.3.3.2
Mud	M	2.2.6
Mudcracks	Mdcrk	4.3.6.13
Mud log		1.3.1
Mud to surface	MTS	2.2.6
Mud volcanoes on maps		2.5.5
Multilateral holes		2.1.5
Multilateral horizontal holes		2.1.6

Muscovite	Musc	4.3.4
N		
Nannoplankton, calcareous	Nanplk	4.3.5.2
Natural fluorescence		2.3
Natural flow	NF	2.1.2.3
Natural Gamma Ray Spectrometry Log	NGS	1.3.2
neritic		4.5.1.2
Neutron porosity	NPH	1.3.2
Nodules	Nod	4.3.7.3
Nodules, ferruginous	fe-Conc	4.3.7.3
Nodules, phosphatic	phos-Conc	4.3.7.3
Nodules, siderite	sid-Conc	4.3.7.3
non-commercial	NC	2.1.2.3
non-porous	nonpor	4.3.2.4
not compacted	not comp	4.3.1.5
O		
Observation (of productive well)	Obs	2.1.2.3
Oil	O	2.2.6
Oil-based mud	OBM	2.2.1
Oil (condensate) injector	OI	2.1.2.3
Oil cut mud	OCM	2.2.6
Oil down to	ODT	2.4
Oil fields (incl. pre/post-production) on maps		2.4
Oil fields with gas cap (incl. post-production) on maps		2.4
Oil on subsurface maps and sections		2.4
Oil producer	OP	2.1.2.3
Oil seeps (shows) on maps		2.5.2
Oil source rock		5.1.1
Oil to surface	OTS	2.2.6
Oil up to	OUT	2.4
Oil/water contact	OWC	2.4
Oil, well bore symbols		2.2.8.2
Oligostegina	Oligst	4.3.5.2
Olistolith	Olisth	4.3.6.5
Olistostrome	Olistr	4.3.6.5
olive	olv	4.3.3.1
Olivine	Olv	4.3.4
Onkoid (1/16 - 2mm)	Onk	4.3.1.8
Onkoid (>2mm)	Onkd	4.3.1.8
Onlap		4.4.5.2
Ooid	Oo	4.3.1.8
Ooid, ghosts		4.3.7.2
Ooid, superficial	Oo, spf	4.3.1.8
Open hole	O	2.1.2.5
Ophiolites		4.2.8.4
Ophiolites, colour symbol		4.2.10
orange	orng	4.3.3.1
Organic rich rocks		4.2.6
Original oil/water contact	OOWC	2.4
Orthoclase	Orth	4.3.4
Ostracods	Ost	4.3.5.2
overbalanced	O/B	2.2.1
Overpressures		4.7.5
P		
Packer or seal	P	2.2.4
Palaeoenvironments, abbreviations		4.5.1.1
Palaeogeographical maps		4.6
Palaeogeographical maps, basin scale		4.6.1
Palaeogeographical maps, continental/global scale		4.6.2
Palaeogeographical maps, depositional environment and lithology, colours		4.6.2
Palaeogeographical maps, depositional environments, colours		4.6.1

Palaeogeographical maps, lithological symbols		4.6.1
Palaeogeographical maps, miscellaneous symbols		4.6.1
Palaeogeographical maps, (plate-)tectonic symbols		4.6.2
papery	pap	4.3.6.4
Parasequence	P	4.4.4
Parasequence set	PS	4.4.4
Particles, non-skeletal		4.3.1.6
Particles, non-skeletal, size		4.3.1.7
Particles, non-skeletal, texture		4.3.1.7
Particles, rounded	Psoo	4.3.1.6
Particles, rounded, aggregated	Gpst	4.3.1.6
Peat		4.2.6
Pebble	Pbl	4.3.1.1
Pebble imbrication	pbl-lmb	4.3.6.13
Pelagic foraminifera, broken		4.3.1.9
Pelecypods	Pelcp	4.3.5.2
Pelite	Pel	4.3.1.1
Pelletoid	Peld	4.3.1.8
Pellets		4.3.1.8
Perforation		2.2.4
Peridotites	Pdt	4.2.8.1
Permeability		4.3.2
Permeability, qualitative		4.3.2.5
permeable	perm	4.3.2.5
permeable, highly	<u>perm</u>	4.3.2.5
permeable, moderately (fairly)	perm	4.3.2.5
permeable, slightly (poorly)	(perm)	4.3.2.5
Phacoids		4.3.6.13
Phosphate	Phos	4.2.7
Photogeology		4.1
Photogeology, geological features		4.1.2
Photogeology, morphological features		4.1.1
Phyllite	Phy	4.2.9
pink	pk	4.3.3.1
Pisoid	Piso	4.3.1.8
Pits, gas, air or spring		4.3.6.13
Plagioclase	P; Plag	4.2.8.1; 4.3.4
Plant remains	Plt Rem	4.2.6; 4.3.5.2
Plant root tubes	Plt Rt	4.3.5.4
Platform		2.1.1
Play maps and cross-sections		1.3.6
plugged back	PB	2.2.3
Plunger lift	PL	2.1.2.3
Plutonic rocks	Plut	4.2.8.1
Plutonic rocks, colour symbol		4.2.10
Polyhalite	Ph	4.2.5
Polymer injection	PI	2.1.2.3
Porosity		4.3.2
Porosity, cavernous	cav, cav Por	4.3.2.2
Porosity, channel	chnl Por	4.3.2.2
Porosity, fabric selective		4.3.2.1
Porosity, fenestral	fnstr Por	4.3.2.1
Porosity, fine interparticle	f interpart Por	4.3.2.1
Porosity, fracture	Frac Por	4.3.2.2
Porosity, framework	Frmwk Por	4.3.2.1
Porosity, intercrystalline	interxln Por	4.3.2.1
Porosity, intergranular	intergran Por	4.3.2.1
Porosity, intracrystalline	intraxln Por	4.3.2.1
Porosity, intragranular	intragran Por	4.3.2.1
Porosity, intraskeletal	intraskel Por	4.3.2.1
Porosity, mouldic	mld Por	4.3.2.1
Porosity, non-fabric selective		4.3.2.2
Porosity, primary		4.3.2.3
Porosity, qualitative		4.3.2.4

Porosity, relative timing of generation		4.3.2.3
Porosity, replacement	repl Por	4.3.2.2
Porosity, secondary		4.3.2.3
Porosity, shelter	Shelt Por	4.3.2.1
Porosity, solution	sol Por	4.3.2.2
Porosity, stylolitic	stltc Por	4.3.2.2
Porosity, vuggy	vug, vug Por	4.3.2.2
Porosity, vugular	vug, vug Por	4.3.2.2
porous	por	4.3.2.4
porous, fairly	por	4.3.2.4
porous, highly	por	4.3.2.4
porous, slightly (poorly)	(por)	4.3.2.4
Porphyry	Po	4.2.8.3
Post-depositional features		4.3.7
Post-depositional features, miscellaneous		4.3.7.1
Potassium salts		4.2.5
Power oil	PO	2.1.2.3
Pressure reading	P	2.2.6
Pressure Temperature Sonde	PTS	1.3.2
Processing, seismic		6.1.2
Prod casts	prod-Cs	4.3.6.13
Production Log/Flow Profiles	PL	1.3.2
Production results		2.2.6
Production status, well		2.1.2.3
Production test (results)	PT	2.1.2.2; 2.2.6; 2.2.8.1
Productive well		2.1.2.2; 2.1.2.3
Prograding (forestepping) parasequence set	PPS	4.4.4
Prospects on maps		2.4
Pseudo-nodules	Psnod	4.3.6.13
Pseudoid	Psoo	4.3.1.6
Pseudo oil-based mud	PSOBM	2.2.1
Pull-apart structure		4.3.7.2
pumped	P	2.2.6
purple	pu	4.3.3.1
Pyrite	Pyr	4.3.4
Pyroclastic rocks	PyrcI	4.2.8.3
Pyroxene	Px	4.3.4
Q		
Quantity symbols, distribution charts		4.4.2.3
Quartz	Qz	4.2.2.1; 4.2.8.1; 4.3.4
Quartz arenite		4.3.1.10
Quartzite	Qzt	4.2.9
R		
Radiolaria	Rad	4.3.5.2
Rauhacke	Rauhw	4.3.7.2
Ravinement surface		4.4.4
Re-activated faults		4.7.2.2
recrystallized	rex	4.2.3.1
red	red	4.3.3.1
Red beds	Redbd	4.3.7.1
Reef		4.3.6.5; 4.5.2
Reef limestones, classification		4.2.3.1
References		At the end
Regressive surface of erosion	RSE	4.4.4
Repeat Formation Sampler	RFS	1.3.2
Repeat Formation Tester	RFT	1.3.2
Report presentation		1.2
Resistivity	RES, r	1.3.2; 2.2.6
Returns	Ret	2.1.2.2; 2.2.8.1-2
Retrograding (backstepping) parasequence set	RPS	4.4.4
Rhyolite	RI	4.2.8.3

Rift tectonics, trap styles		4.7.6.2
Ripple-drift	xbd-r	4.3.6.6
Ripplemarks on bedding planes		4.3.6.7
Ripples, adhesion	adh-Rpl	4.3.6.7
Ripples, asymmetrical	asym-Rpl	4.3.6.7
Ripples, barchanoid	conc-Rpl	4.3.6.7
Ripples, crescentic	conc-Rpl	4.3.6.7
Ripples, interference	intf-Rpl	4.3.6.7
Ripples, linguoid	conx-Rpl	4.3.6.7
Ripples, lobate	conx-Rpl	4.3.6.7
Ripples, lunate	conc-Rpl	4.3.6.7
Ripples, parallel	plan-Rpl	4.3.6.7
Ripples, planar	plan-Rpl	4.3.6.7
Ripples, symmetrical	sym-Rpl	4.3.6.7
Rock description		4.3
Rock description, composition		4.3.1
Rock description, texture		4.3.1
Rock Eval data, interpretation of		5.1.2.1
Rock fragment	Lcl	4.2.2.1
Rock salt		4.2.5
Rock salt, colour symbol		4.2.10
Rockfall	Olisth	4.3.6.5
Root bed		4.2.6
Rootlets	Plt Rt	4.3.5.4
Rotary drilling	Rot	2.2.1
rounded	rnd	4.3.1.3
rounded, sub-	(rnd)	4.3.1.3
rounded, well	rnd	4.3.1.3
Round holes (completion)	RH	2.2.4
Roundness		4.3.1.3
Rudists	Rud	4.3.5.2
Rudite		4.3.1.1
Rudstone		4.2.3.1
S		
Salt		4.2.5
Salt, colour symbol		4.2.10
Salt moulds or hoppers	salt-Mld	4.3.6.13
Salt tectonics, trap styles		4.7.6.2
Salt water cut mud	SWCM	2.2.6
Sand	S	4.2.2.2
Sand, colour symbol		4.2.10
Sand-frac	SF	2.2.5
Sandstone	Sst	4.2.2.2
Sandstone, colour symbol		4.2.10
sandy	s	4.2.2.2
Sandy limestone	Lst, s	4.2.4
Sapropelic coal	C, sapropel	4.2.6
Saw slots (completion)	SS	2.2.4
Schist	Sch	4.2.9
Schistosity		4.7.4.2
Scour-and-fill		4.3.6.5
Scour-and-fill, foreset infill		4.3.6.5
Scour-and-fill, horizontal infill		4.3.6.5
Scratcher(s)	S	2.2.3
Screw pump	SP	2.1.2.3
Seal or packer	P	2.2.4
Sediment deformation, oversteepening		4.3.6.12
Sediment deformation, overturning		4.3.6.12
Sediment deformation, soft		4.3.6.12
Sedimentary dyke	Dyke	4.3.6.12
Sedimentary features, large		4.3.6.5
Sediments, miscellaneous		4.2.7
Seismic		6.1

Seismic acquisition and location maps		6.1.1
Seismic attribute maps		6.1.3.2
Seismic contour maps		6.1.3.4
Seismic display		6.1.2
Seismic facies colour scheme		6.1.3.3
Seismic facies mapping		6.1.3.3
Seismic facies notation scheme		6.1.3.3
Seismic facies symbols on maps		6.1.3.3
Seismic interpretation		6.1.3
Seismic polarity conventions		6.1.2.3
Seismic processing and display		6.1.2
Seismic reflection termination on seismic maps		6.1.3.4
Seismic sections, data along section		6.1.2.2
Seismic sections, display parameters		6.1.2.1
Seismic sections, display scales		6.1.2.1
Seismic sections, interpreted		6.1.3.1
Seismic sections, processing parameters		6.1.2.1
Seismic sections, recording parameters		6.1.2.1
Seismic sections, side label display		6.1.2.1
Seismic stratigraphy		6.1.3.3
Selenite	Sel	4.3.4
Sequence boundary	SB	4.4.4
Sequence stratigraphy		4.4.4
Service well	SV	2.1.2.7
Shale	Sh	4.2.2.2
Shale, colour symbol		4.2.10
shaled out	sh	2.1.2.6
Shoreface, lower		4.5.2
Shoreface, upper		4.5.2
Shows		2.1.2.2
Shut in bottom hole pressure after x minutes	SIBHP/x min	2.2.6
Siderite	Sid	4.3.4
Sidetrack	SDTR	2.1.3
Sidewall core	SWC	2.1.2.2; 2.2.2 2.2.8.1; 2.2.8.5
Sidewall sample	SWS	2.1.2.2; 2.2.2; 2.2.8.1; 2.2.8.5
Siliciclastics		4.2.2
Siliciclastics, compositional classification		4.3.1.10
Siliciclastics, framework composition		4.2.2.1
Siliciclastics lithotypes		4.2.2.2
Silicilith	Sct	4.2.7
Silicilyte	Sct	4.2.7
Sill		4.2.8.2
Silt	Slt	4.2.2.2; 4.3.1.1
Silt, colour symbol		4.2.10
Siltstone	Sltst	4.2.2.2
Siltstone, colour symbol		4.2.10
Single buoy mooring	SBM	3.4.4
Site survey test hole	SS	2.1.2.7
Skeletal particles		4.3.1.9
Slate	Sl	4.2.9
slickensided	sks	4.3.7.1
Slide	Olisth	4.3.6.5
slight (colour)		4.3.3.2
Slightly oil cut mud	SIOCM	2.2.6
Slim hole	S	2.1.2.7; 2.2.1
Slope		4.5.2
slumped	slump	4.3.6.12
Soil bed		4.3.7.1
Soil pisoids		4.3.7.3
Solid hydrocarbons on maps		2.5.3
Solid hydrocarbons, well bore symbols		2.2.8.3
Solution breccia	Bc, sol	4.3.7.2

Solvent cut, colour		2.3
Solvent fluorescence, intensity		2.3
Sonic travel time	SON	1.3.2
sorted, bimodally	bimod srt	4.3.1.2
sorted, moderately well	srt	4.3.1.2
sorted, poorly	(srt)	4.3.1.2
sorted, unimodally	unimod srt	4.3.1.2
sorted, very poorly	((srt))	4.3.1.2
sorted, very well	<u>srt</u>	4.3.1.2
sorted, well	<u>srt</u>	4.3.1.2
Sorting		4.3.1.2
Source rock evaluation		5.1.2
Source rock maturity and hydrocarbon generation		5.2
Source rock type		5.1.1
Source rocks	SR	5.1
spherical	sph	4.3.1.4
spherical, slightly	(sph)	4.3.1.4
spherical, very	sph	4.3.1.4
Sphericity		4.3.1.4
Spicules	Spic	4.3.5.2
Spontaneous Potential	SP	1.3.2
Sporomorphs	Spr	4.3.5.2
squeeze cemented	Sq C	2.2.3
Stage collar	SC	2.2.3
Standard documents		1.3
Standard test fraction		2.2.5; 2.2.6
Steam injection	SI	2.1.2.3
Stratification		4.3.6
Stratification, crinkled	crink-bd	4.3.6.9
Stratification, flaser		4.3.6.9
Stratification, irregular	irg-bd	4.3.6.9
Stratification, lenticular		4.3.6.9
Stratification, parallel wavy		4.3.6.9
Stratification, streaky		4.3.6.9
Stratigraphical boundaries on layer maps		4.4.5.2
Stratigraphical boundaries on maps		4.4.5.1
Stratigraphical traps		4.7.6.1
Stratigraphic High-Resolution Dipmeter	SHDT	1.3.2
Stratigraphy		4.4
Stratigraphy, seismic		6.1.3.3
Striation casts	stri-Cs	4.3.6.13
Strike symbols on surface geological maps		4.7.4
Stromatactis		4.3.7.2
Stromatolites	Alg Mat	4.3.5.4
Stromatolites, domal	Alg Dom	4.3.5.4
Stromatoporoids	Strom	4.3.5.2
strong (colour)		4.3.3.2
Structural features, miscellaneous		4.7.4.2
Structural geology		4.7
Structural traps		4.7.6.1
Structure hole	SH	2.1.2.7
Structures, organogenic		4.3.5.4
Structures, sedimentary		4.3.6
Structures, syndepositional		4.3.6.13
stuck (casing)	S	2.2.3
Stylolites		4.3.7.2
Sub-arkose		4.3.1.10
Sub-litharenite		4.3.1.10
Subsurface location symbols		2.1.2
sucrosic	suc	4.2.3.1
Sulphur	Su	4.3.4
Superficial ooid	Oo, spf	4.3.1.8
Supergroup	Supgp	4.4.1.1
Surface, erosional		4.3.6.3

Surface hydrocarbon seeps (shows) on maps		2.5
Surface location symbols		2.1.1
Surface water springs, seepages on maps		2.5.4
swabbed	Sw	2.2.6
Syenite	Sy	4.2.8.1
Syenitoids		4.2.8.1
Sylvinite	Sv	4.2.5
Synclines		4.7.3
Syneresis cracks		4.3.6.13
Systems tracts		4.4.4
T		
Tachydrite	Ty	4.2.5
Tadpole nests		4.3.6.7
Tar shows	T	2.1.2.2
Technical status, well		2.1.2.1
Temperature Log	TL	1.3.2
Temperature survey	TS	2.1.2.2; 2.2.3; 2.2.8.1
Template		2.1.1
Tepee structure		4.3.6.13
terrestrial		4.5.1.2; 4.5.2
Test data		2.2.6
Test fraction		2.2.6
thermal (gas)	T	2.2.8.1
thermal (gas): humic source	TH	2.2.8.1
thermal (gas): kerogenous source	TK	2.2.8.1
Thermal (Neutron) Decay Time Log	TDT	1.3.2
Thermally activated mud emulsion	TAME	2.2.1
Thrust tectonics, trap styles		4.7.6.2
Tillite	Tilt	4.2.2.2
Time/rock synopsis		4.4.6.1
Tintinnids	Tin	4.3.5.2
Tongue	Tng	4.3.6.5; 4.4.1.1
Top cement	TC	2.2.3
Topography		3.0
Topography, artificial features		3.4
Topography, bathymetric contours		3.7
Topography, boundaries		3.3
Topography, elevation contours		3.6
Topography, natural features		3.5
Topography, survey datum		3.1
Topography, survey reference points		3.2
Total depth	TD	2.1.2.1
Trace fossils		4.3.5.3
Tracks, vertebrate		4.3.5.3
Trails		4.3.5.3
Transgressive surface	TS	4.4.4
Transgressive surface of erosion	TSE	4.4.4
Transgressive systems tract	TST	4.4.4
translucent	transl	4.3.3.1
Trap descriptions		4.7.6
Trap elements, basic -		4.7.6.1
Trap styles		4.7.6.2
Trap styles in delta tectonic settings		4.7.6.2
Trap styles in inversion tectonic settings		4.7.6.2
Trap styles in rift tectonic settings		4.7.6.2
Trap styles in salt tectonic settings		4.7.6.2
Trap styles in wrench tectonic settings		4.7.6.2
Trilobites	Tril	4.3.5.2
true vertical	TV	2.1.3
True vertical depth	TVD	App. 6
True vertical depth subsea	TVDSS	1.3.1; 1.3.3; 2.1.5; App. 5

True vertical thickness		App. 6
Tubing accessories, engineering symbols		2.2.4
Tuff	Tf	4.2.8.3
Type of well		2.1.2.7
U		
Ultramafic rocks		4.2.8.1
Unconformity	U	4.4.1.2; 4.4.5.1
Unconformity, angular		4.4.5.1
Unconformity, truncation		4.4.5.1
unconsolidated	uncons	4.3.7.1
underbalanced	U/B	2.2.1
Unit with concave bottom and flat top		4.3.6.5
Unit with convex top and flat bottom		4.3.6.5
Upper; upper	Up; up	4.4.1.1; 4.4.3
V		
variegated	vgt	4.3.3.2
Varves	Varv	4.3.6.8
Vein, sedimentary	Vn	4.3.6.12
Vertebrate tracks		4.3.5.3
Vertebrates	Vrtb	4.3.5.2
Vertical seismic profile	VSP	6.1.4
Vintage hydrocarbon show symbols		2.2.8.5
Vitrinite reflectance	VR	5.2.1
Vitrinite reflectance/estimated	VR/E	5.2.1
Vitrinite reflectance/measured	VR/M	5.2.1
Volcanic breccia	Ag, vo	4.2.8.3
Volcanic rocks	Vo	4.2.8.3
Volcanic rocks, colour symbol		4.2.10
W		
Wacke		4.3.1.10
Water	W	2.1.2.3; 2.2.6
Water-based mud	WBM	2.2.1
Water cushion	WC	2.2.6
Water cushion to surface	WCTS	2.2.6
Water cut mud	WCM	2.2.6
Water down to	WDT	2.4
Water filled structure on maps		2.4
Water injection	WI	2.1.2.3
Water on subsurface maps and sections		2.4
Water producer	WP	2.1.2.3
Water up to	WUT	2.4
weak (colour)		4.3.3.2
weathered	weath	4.3.7.1
wedged out	WO	2.1.2.6
Wedge-shaped layer	Wdg	4.3.6.5
Wedge-out edge		4.4.5.2
Welded tuff	Tf, weld	4.2.8.3
Well bore symbols		2.2
Well closed in		2.1.2.3
Well completion (composite) log		1.3.3
Well completion status		2.1.2.5
Well deviation		2.2.1
Well, geological/structural information		2.1.2.6
Well hydrocarbon status		2.1.2.2
Well injection status		2.1.2.4
Well production status		2.1.2.3
Well, productive		2.1.2.2; 2.1.2.3
Well proposal		1.3.4
Well résumé		1.3.5
Well shoot		6.1.4
Well symbols on maps and sections		2.1

Well type		2.1.2.7
Wells and hydrocarbons		2.0
white	wh	4.3.3.1
Wireline bridge plug	WLBP	2.2.3
Wireline formation tester	WFT	2.1.2.2
Wirewrapped screen	WW; WWS	2.2.4
Wood, silicified	Wd, si	4.3.5.2
Wrench tectonics, trap styles		4.7.6.2
Y		
yellow	yel	4.3.3.1
Z		
Zonal terminology		4.4.2.1
Zonation		4.4.2.2
Zone		4.4.2.2
Zone/zonation, benthonic foraminifera	BF-zone/zonation	4.4.2.2
Zone/zonation, calcareous nannoplankton	N-zone/zonation	4.4.2.2
Zone/zonation, chitinozoa	C-zone/zonation	4.4.2.2
Zone/zonation, foraminiferal	F-zone/zonation	4.4.2.2
Zone/zonation, micropalaeontological	PA-zone/zonation	4.4.2.2
Zone/zonation, microplankton	M-zone/zonation	4.4.2.2
Zone/zonation, palynological	PY-zone/zonation	4.4.2.2
Zone/zonation, planktonic foraminifera	PF-zone/zonation	4.4.2.2
Zone/zonation, sporomorph	S-zone/zonation	4.4.2.2

ALPHABETICAL LISTING OF ABBREVIATIONS

Abbreviations of chronostratigraphical units see Appendix 3

Abbreviation	Subject	Section
A		
A	Alkali feldspars	4.2.8.1
A	Aphanitic lime mudstone	4.2.3.1
AB	Abandonment	2.1.2.3
ABL	abyssal	4.5.1.1
Acet	Acetone	2.2.8.5
Acrt	Acritarchs	4.3.5.2
adh-Rpl	Adhesion ripples	4.3.6.7
AF	Acid-frac	2.2.5
Ag, vo	Agglomerate, volcanic breccia	4.2.8.3
AH	along hole	2.1.3
AHD	Along hole depth	App. 5
AL	Air lift	2.2.6
Alg	Algae	4.3.5.2
Alg Dom	Algal domes, domal stromatolites	4.3.5.4
Alg Mat	Algal mats, stromatolites	4.3.5.4
Am	Amphibolite	4.2.9
Amm	Ammonites	4.3.5.2
amor	amorphous	4.3.6.4
An	Andesite	4.2.8.3
(ang)	subangular	4.3.1.3
ang	angular	4.3.1.3
<u>ang</u>	very angular	4.3.1.3
Anhd	Anhydrite	4.2.5; 4.3.4
anhd-Conc	Anhydrite concretions	4.3.7.3
Anthr	Anthracite	4.2.6
Ao	Anorthosite	4.2.8.1
aph	aphanitic	4.2.3.1
APS	Aggrading parasequence set	4.4.4
arg	argillaceous	4.2.2.2
Ark	Arkose	4.2.2.2; 4.3.1.10
asym-Rpl	Asymmetrical ripples	4.3.6.7
AT	Acid treatment	2.2.5
B		
B, b	Barrel(s)	2.2.6
B	biogenic, bacterial (gas)	2.2.8.1
B	Lime boundstone	4.2.3.1
Ba	Basalt	4.2.8.3
BAT	bathyal	4.5.1.1
BC	Bentonite cement	2.2.3
Bc, sol	Solution breccia	4.3.7.2
Bcl, ang	Angular bioclasts; broken, angular unspecified fossils	4.3.1.9
Bcl, rnd	Rounded bioclasts; broken, rounded, unspecified fossils	4.3.1.9
Bd	Bed	4.4.1.1
(bd)	slightly (poorly) bedded	4.3.6.2
bd	bedded	4.3.6.2
<u>bd</u>	well bedded	4.3.6.2
<u>bd</u>	very well bedded	4.3.6.2
<u>bdf</u>	below drilling floor	App. 5
Bdst	Lime boundstone	4.2.3.1
BFF	Basin floor fan complex	4.4.4
BF-zone/zonation	Benthonic foraminifera zone/zonation	4.4.2.2
BHC	Borehole Compensated Sonic Log	1.3.2
BHP	Bottom hole pressure	2.2.6
BHT	Bottom hole temperature	1.3.3
BHTV	Borehole Televiwer	1.3.2
Bi	Bischofite	4.2.5

bimod srt	bimodally sorted	4.3.1.2
Biot	Biotite	4.3.4
bit	bituminous	4.2.6
Biv	Bivalves	4.3.5.2
Bl	bailed	2.2.6
Bld	Boulder	4.3.1.1
blk	black	4.3.3.1
blk _y	blocky	4.3.6.4
Blm	Belemnites	4.3.5.2
blu	blue	4.3.3.1
BO	Barrel(s) of oil	2.2.6
Bor	Borings, animal tubes	4.3.5.3
BP	Beam pump	2.1.2.3
BP	Bridge plug	2.2.3
Brac	Brachiopods	4.3.5.2
Brc	Breccia	4.2.2.2
brn	brown	4.3.3.1
Bry	Bryozoa	4.3.5.2
buf	buff	4.3.3.1
Bur	Burrows, vertical or horizontal	4.3.5.3
BW	Barrel(s) of water	2.2.6
C		
C	Casing	2.2.3
c	carbonaceous	4.2.6
C	Centralizer(s)	2.2.3
C	Coal	4.2.6
C	Condensate	2.2.6
C	Conservation (of productive well)	2.1.2.3
C	Core	2.1.2.2; 2.2.8.1; 2.2.8.5
C, bit	Bituminous coal	4.2.6
C, hd	Hard coal	4.2.6
C, humic	Humic coal	4.2.6
C, sapropel	Sapropelic coal, cannel coal, boghead	4.2.6
C-zone/zonation	Chitinozoa zone/zonation	4.4.2.2
CAD	Coring after drilling	2.2.2
CAL	Caliper	1.3.2
Calc	Calcite	4.3.4
calc	calcareous	4.2.3.2
calc-Conc	Calcareous concretions	4.3.7.3
Calsph	Calcispheres	4.3.5.2
cav	cavernous	4.3.2.2
cav Por	Cavernous porosity	4.3.2.2
CBL	Cement Bond Log	1.3.2
Cbl	Cobble	4.3.1.1
CCgl	Coal conglomerate	4.2.6
CDL	Compensated Densilog	1.3.2
Cgl	Conglomerate	4.2.2.2
CH	Core hole	2.1.2.7
Char	Charophytes	4.3.5.2
Chk	Chalk	4.2.3.2
chnl Por	Channel porosity	4.3.2.2
Cht	Chert	4.2.7
Chtz	Chitinozoa	4.3.5.2
Cl	Clay	4.2.2.2; 4.7.7.1
Clst	Claystone	4.2.2.2; 4.3.1.10
cm-bd	centimetre bedded	4.3.6.1
(cmp)	slightly compacted	4.3.1.5
cmp	compacted	4.3.1.5
<u>cmp</u>	strongly compacted	4.3.1.5
cmt	cemented	4.3.7.1
<u>cmt</u>	strongly (highly) cemented	4.3.7.1
Cn	Carnallite	4.2.5

CNL	Compensated Neutron Log	1.3.2
COF	coastal, fluviomarine	4.5.1.1
COL	coastal, holomarine	4.5.1.1
Comp	Completion	2.2.1
Con	Conodonts	4.3.5.2
Conc	Concretions	4.3.7.3
conch	conchoidal	4.3.6.4
conc-Rpl	Lunate, barchanoid, crescentic ripples	4.3.6.7
(cons)	slightly consolidated	4.3.7.1
cons	consolidated	4.3.7.1
<u>cons</u>	strongly (highly) consolidated	4.3.7.1
CONT	continental	4.5.1.1
cont-bd	Contorted bedding	4.3.6.12
conv-bd	Convolute bedding	4.3.6.12
conx-Rpl	Linguoid, lobate ripples	4.3.6.7
Cor	Corals	4.3.5.2
CP	Coastal plain	4.5.1.1
CP	Cemented through perforations	2.2.3
CR	Caprock	2.1.2.6
CR	Cement retainer	2.2.3
Crin	Crinoids	4.3.5.2
crink-bd	Crinkled stratification	4.3.6.9
crs	coarse	4.3.1.1
Csg	Casing	2.1.2.5
CST	Condensed systems tract (condensation horizons)	4.4.4
CST	Continuous Sample Taker	1.3.2
CTB	Coiled tubing	2.1.2.7; 2.2.1
Ctg	Cuttings	2.1.2.2; 2.2.8.1; 2.2.8.5
Cx	Complex	4.4.1.1
D		
D	Disconformity	4.4.1.2; 4.4.5.1
Db	Diabase	4.2.8.2
DEN	Density	1.3.2
DF	Debris flows/slumps	4.4.4
DHI	Direct hydrocarbon indication	1.3.4
Diat	Diatoms	4.3.5.2
Dinfl	Dinoflagellates	4.3.5.2
dk	dark	4.3.3.2
DLL	Dual Laterolog	1.3.2
dm-bd	decimetre bedded	4.3.6.1
Do	Dolerite	4.2.8.2; 4.2.8.3
Dol	Dolomite	4.2.3.2; 4.3.4
dol	dolomitic	4.2.3.2
Dol-Lst	Dolomite-limestone, equal mixture	4.2.3.2
DR	Daily rate	2.2.6
Dr	Diorite	4.2.8.1
Dr	driven (casing)	2.2.3
Drgfld, sed	Drag folds (sedimentary)	4.3.6.12
Drill	Drilling	2.2.1
DST	Drillstem test	2.1.2.2; 2.2.6; 2.2.8.1
DV FO	Displacement valve full opening	2.2.3
DWF	Deep water fan system (undiff.)	4.4.4
Dy	Dyke	4.2.8.2
Dyke	Sedimentary dyke	4.3.6.12
E		
E	Evaporite	4.7.7.1
Ech	Echinoderms	4.3.5.2
EL	Electric logs	2.2.8.1
ELEV	Elevation reference level	1.3.1; 1.3.3; App. 5
(elong)	slightly elongated	4.3.1.4

elong	elongated	4.3.1.4
<u>elong</u>	very elongated	4.3.1.4
ER	Electrical submersible pump	2.1.2.3
ESP	Electrical submersible pump	2.2.4
Ex	Extrusive rocks	4.2.8.3
Ey; ey	Early; early	4.4.3
F		
F	Fault, columnar sections	4.4.6.1
F	Feldspathoids, foids	4.2.8.1
F	flowed	2.2.6
f	faulted out	2.1.2.6
f	fine	4.3.1.1
f interpart Por	Fine interparticle porosity	4.3.2.1
F-zone/zonation	Foraminiferal zone/zonation	4.4.2.2
Fac	Facilities	2.1.2.3
FDC	Formation Density Log	1.3.2
fe	ferruginous	4.2.7
fe-Conc	Ferruginous concretions or nodules	4.3.7.3
Fest	Ironstone	4.2.7
FFBHP	Final flowing bottom hole pressure	2.2.6
FFSP	Final flowing surface pressure	2.2.6
FIN	fluviomarine, inner neritic	4.5.1.1
fis	fissile	4.3.6.4
Fish Rem	Fish remains	4.3.5.2
Fish Sc	Fish scales	4.3.5.2
FIT	Formation Interval Tester	1.3.2
FL	Fluid level	2.2.6
FL	Fluid lift	2.1.2.3
Fld	Feldspar	4.2.2.1; 4.3.4
flk	flaky	4.3.6.4
flt	faulted	4.3.7.1
Flu	Fluorescence	2.2.8.5
flut-Cs	Flute casts	4.3.6.13
Fm	Formation	4.4.1.1
FMI	Formation MicroImager	1.3.2
FMN	fluviomarine, middle neritic	4.5.1.1
FMS	Formation MicroScanner Log	1.3.2
FN	Normal fault, columnar sections	4.4.6.1
fnstr Por	Fenestral porosity	4.3.2.1
FON	fluviomarine, outer neritic	4.5.1.1
Foram	Foraminifera	4.3.5.2
Foram, lg	Larger foraminifera	4.3.5.2
Foram, pelg	Pelagic foraminifera	4.3.5.2
Foram, plk	Planktonic foraminifera	4.3.5.2
Foram, sm	Smaller foraminifera	4.3.5.2
Foram, sm, bnt	Smaller, benthonic foraminifera	4.3.5.2
Foss	Unspecified fossils	4.3.1.9; 4.3.5.1
Foss, bent	Benthonic fossils	4.3.5.1
Foss, brack	Brackish water fossils	4.3.5.1
Foss, fresh	Fresh water fossils	4.3.5.1
Foss, mar	Marine fossils	4.3.5.1
Foss, pelg	Pelagic fossils	4.3.5.1
foss-Lin	Fossil (shell) lineation	4.3.6.11
FR	Reverse fault, columnar sections	4.4.6.1
FRAC	Unspecified fracturing (of reservoir)	2.2.5
frac	fractured	4.3.7.1
Frac Por	Fracture porosity	4.3.2.2
fri	friable	4.3.1.5; 4.3.7.1
Frmwk Por	Framework porosity	4.3.2.1
FRW	Forced regressive shoreface wedge	4.4.4
FS	Flooding surface	4.4.4
FSIBHP	Final shut in bottom hole pressure	2.2.6
FT	Thrust fault, columnar sections	4.4.6.1

FWL	Free water level	2.4
G		
G	Gas	2.2.6
G	Lime grainstone	4.2.3.1
GAM	Gamma Ray	1.3.2
Gast	Gastropods	4.3.5.2
Gb	Gabbro	4.2.8.1
GCG	Grains NaCl per gallon	2.2.6
GCM	Gas cut mud	2.2.6
GCP	Gas/condensate producer	2.1.2.3
GCR	Gas/condensate ratio	2.2.6
GDT	Gas down to	2.4
GHMT	Geological High Resolution Magnetic Tool	1.3.2
GI	Gas injector	2.1.2.3
GL	Gas lift	2.1.2.3; 2.2.6
GL	Ground level	1.3.1; 1.3.3; App. 5
GLC	Gas/liquid contact	2.4
Glc	Glauconite	4.2.7; 4.3.4
gn	green	4.3.3.1
Gns	Gneiss	4.2.9
GOC	Gas/oil contact	2.4
GOCM	Gas and oil cut mud	2.2.6
GOR	Gas/oil ratio	2.1.2.3; 2.2.6
GP	Gas producer	2.1.2.3
GP	Gravel pack(ed)	2.1.2.5; 2.2.4
Gp	Group	4.4.1.1
Gpst	Grapestone; rounded, aggregated particle	4.3.1.6
GR	Gamma Ray Log	1.3.2
Gr	Granite	4.2.8.1
grain-Lin	Sand grain lineation	4.3.6.11
Gran	Granule	4.3.1.1
Grap	Graptolites	4.3.5.2
grd-bd	Graded beds, graded bedding	4.3.6.10
Grdr	Granodiorite	4.2.8.1
grov-Cs	Groove casts	4.3.6.13
Grst	Lime grainstone	4.2.3.1
Grv	Gravel	4.2.2.2
GST	Gamma Ray Spectroscopy Log	1.3.2
GTS	Gas to surface	2.2.6
GUT	Gas up to	2.4
GWC	Gas/water contact	2.4
Gwke	Greywacke	4.2.2.2
gy	grey	4.3.3.1
Gyp	Gypsum	4.2.5; 4.3.4
H		
H	Liner hanger	2.2.4
HC	Hydrocarbon(s)	2.2.2
hd	hard	4.3.1.5; 4.3.7.1
HDT	High Resolution Dipmeter Log	1.3.2
HDT	Hydrocarbons down to	2.4
HFW	Hole full of salt water	2.2.8.4
Hi	Hiatus	4.4.1.2
HIN	holomarine, inner neritic	4.5.1.1
HMN	holomarine, middle neritic	4.5.1.1
HOCM	Heavily oil cut mud	2.2.6
HON	holomarine, outer neritic	4.5.1.1
HP	Hydraulic pump	2.1.2.3
HP	Hydrostatic pressure	2.2.6
Hrb	Hornblende	4.3.4
HST	Highstand systems tract	4.4.4
HUT	Hydrocarbons up to	2.4

I		
IFBHP	Intitial flowing bottom hole pressure	2.2.6
IFSP	Initial flowing surface pressure	2.2.6
Ig	igneous	4.7.7.1
IL	Induction Logging	1.3.2
Ill	Illite	4.3.4
imperm	impermeable	4.3.2.5
In	Intrusive rocks	4.2.8.1
ind	indurated	4.3.1.5
intergran Por	Intergranular porosity	4.3.2.1
interxn Por	Intercrystalline porosity	4.3.2.1
intf-Rpl	Interference ripples, "tadpole nests"	4.3.6.7
intragran Por	Intragranular porosity	4.3.2.1
intraske Por	Intraskeletal porosity	4.3.2.1
intraxln Por	Intracrystalline porosity	4.3.2.1
IOEM	Invert oil emulsion mud	2.2.1
IPL	Intermittent lift	2.1.2.3
irg-bd	Irregular wavy bedding	4.3.6.9
ISIBHP	Initial shut in bottom hole pressure	2.2.6
IV	Invalid test	2.1.2.6
IVF	Incised valley fill	4.4.4
J		
JP	Jet pump	2.1.2.3
jt	jointed	4.3.7.1
jt h	horizontally jointed	4.3.7.1
jt v	vertically jointed	4.3.7.1
K		
Ka	Kainite	4.2.5
Kao	Kaolinite	4.3.4
Ki	Kieserite	4.2.5
L		
L	landed (casing)	2.2.3
L	Liner	2.1.2.5; 2.2.3
L	Log	2.1.2.2
L; l	Lower; lower	4.4.1.1; 4.4.3
L mud, uncons	Unconsolidated lime mud	4.2.3.2
lam	laminated	4.3.6.4
LBAT	lower bathyal	4.5.1.1
Lbr	Lamellibranchs	4.3.5.2
Lbr, pelg	Pelagic lamellibranchs	4.3.5.2
LCC	Leveed channel complex	4.4.4
Lcl	Lithoclast, rock fragment	4.2.2.1; 4.3.1.6
Lcl, aggr	Aggregated lithoclast	4.3.1.6
LCP	Lower coastal plain	4.5.1.1
LDL	Litho Density Log	1.3.2
leach	leached	4.3.7.1
Len	Lens, lentil, lenticular layer	4.3.6.5; 4.4.1.1
Lig	Lignite, brown coal	4.2.6
LL	Laterolog	1.3.2
Lmn	Limonite	4.3.4
load-Cs	Load cast	4.3.6.12
lse	loose	4.3.7.1
LST	Lowstand systems tract	4.4.4
Lst	Limestone	4.2.3.2
Lst, arg	Argillaceous limestone	4.2.4
Lst, dol	Dolomitic limestone	4.2.3.2
Lst, s	Sandy limestone	4.2.4
Lt; lt	Late; late	4.4.3
lt	light	4.3.3.2
LW	Lowstand wedge	4.4.4
Lyr	Layer	4.4.1.1

M		
M	Mafic minerals	4.2.8.1
M	Lime mudstone	4.2.3.1
M; m	Middle/Mid; middle/mid	4.4.1.1; 4.4.3
m	mapped horizon	2.1.5; 2.1.6
m	medium	4.3.1.1
M	Mud	2.2.6
Ma	Million years	4.4.3
m-bd	metre bedded	4.3.6.1
M-zone/zonation	Microplankton zone/zonation	4.4.2.2
Marb	Marble	4.2.9
mass	Massive bedding	4.3.6.2
MBAT	middle bathyal	4.5.1.1
Mbr	Member	4.4.1.1
MC	Modified cement	2.2.3
Mdcrk	Mudcracks	4.3.6.13
Mdst	Lime mudstone	4.2.3.1
Metam	Metamorphic rocks	4.2.9
MFS	Maximum flooding surface	4.4.4
Mic	Mica	4.3.4
Micrpeld	Micropelletoid	4.3.1.8
Migm	Migmatite	4.2.9
mid Por	Mouldic porosity	4.3.2.1
MLL	Micro Laterolog	1.3.2
mm-bd	millimetre bedded	4.3.6.1
mod	medium (colour)	4.3.3.2
mod	moderate	4.3.3.2
Mol	Molluscs	4.3.5.2
Mpl	Microplankton	4.3.5.2
Mrl	Marl	4.2.4
Mrlst	Marlstone	4.2.4
MSCT	Mechanical Sidewall Coring Tool	1.3.2
MSFL	Microspherically Focused Resistivity Log	1.3.2
MSL	Mean sea level	App. 5
MSV	Mean success volume	1.3.4
mtl	mottled	4.3.3.2
Mtmo	Montmorillonite	4.3.4
MTS	Mud to surface	2.2.6
Musc	Muscovite	4.3.4
N		
N-zone/zonation	Calcareous nannoplankton zone/zonation	4.4.2.2
Nanplk	Calcareous nannoplankton	4.3.5.2
NC	non-commercial	2.1.2.3
NF	Natural flow	2.1.2.3
NGS	Natural Gamma Ray Spectrometry Log	1.3.2
Nod	Nodules	4.3.7.3
nonpor	non-porous, dense	4.3.2.4
not comp	not compacted	4.3.1.5
NPH	Neutron porosity	1.3.2
NR	not reached	2.1.2.6
O		
O	Oil	2.2.6
O	Open hole	2.1.2.5
O/B	overbalanced	2.2.1
OBM	Oil base mud	2.2.1
Obs	Observation (of productive well)	2.1.2.3
OCM	Oil cut mud	2.2.6
ODT	Oil down to	2.4
Oi	Oil (condensate) injector	2.1.2.3
Oligst	Oligostegina	4.3.5.2
Olisth	Olistolith, rockfall, slide	4.3.6.5
Olistr	Olistostrome, mass flow	4.3.6.5

Olv	Olivine	4.3.4
olv	olive	4.3.3.1
Onk	Onkoid (1/16 - 2mm)	4.3.1.8
Onkd	Onkoid (>2mm)	4.3.1.8
Oo	Ooid	4.3.1.8
Oo, spf	Superficial ooid	4.3.1.8
OOWC	Original oil/water contact	2.4
OP	Oil producer	2.1.2.3
orng	orange	4.3.3.1
Orth	Orthoclase	4.3.4
Ost	Ostracods	4.3.5.2
OTS	Oil to surface	2.2.6
OUT	Oil up to	2.4
OWC	Oil/water contact	2.4
P		
P	Lime packstone	4.2.3.1
P	Packer or seal	2.2.4
P	Parasequence	4.4.4
P	Plagioclase	4.2.8.1
P	Pressure reading	2.2.6
P	pumped	2.2.6
PA-zone/zonation	Micropalaeontological zone/zonation	4.4.2.2
pap	papery	4.3.6.4
part-Lin	Parting lineation	4.3.6.11
PB	plugged back	2.2.3
Pbl	Pebble	4.3.1.1
pbl-lmb	Pebble imbrication	4.3.6.13
pbl-Lin	Pebble lineation	4.3.6.11
Pdt	Peridotites	4.2.8.1
Pel	Pelite	4.3.1.1
Pel, fae	Faecal pellet	4.3.1.8
Pelcp	Pelecypods	4.3.5.2
Peld	Pelletoid	4.3.1.8
(perm)	slightly (poorly) permeable	4.3.2.5
perm	fairly permeable, permeable	4.3.2.5
<u>perm</u>	highly permeable	4.3.2.5
PF-zone/zonation	Planktonic foraminifera zone/zonation	4.4.2.2
Ph	Polyhalite	4.2.5
Phos	Phosphate	4.2.7
phos-Conc	Phosphatic concretions or nodules	4.3.7.3
Phy	Phyllite	4.2.9
PI	Polymer injection	2.1.2.3
Piso	Pisoid	4.3.1.8
pk	pink	4.3.3.1
Pkst	Lime packstone	4.2.3.1
PL	Plunger lift	2.1.2.3
PL	Production Log/Flow Profiles	1.3.2
Plag	Plagioclase	4.3.4
plan-Rpl	Planar, parallel ripples	4.3.6.7
Plt Rem	Plant remains	4.2.6; 4.3.5.2
Plt Rt	Plant root tubes, rootlets	4.3.5.4
plt-Lin	Plant fragment lineation	4.3.6.11
Plut	Plutonic rocks	4.2.8.1
PO	Power oil	2.1.2.3
Po	Porphyry	4.2.8.3
(por)	slightly (poorly) porous	4.3.2.4
por	porous, fairly porous	4.3.2.4
<u>por</u>	highly porous	4.3.2.4
POS	Probability of success	1.3.4
PPS	Prograding (forestepping) parasequence set	4.4.4
prod-Cs	Prod casts	4.3.6.13
PS	Parasequence set	4.4.4
PSI	Pressure sensing instrument	2.2.4

Psnod	Pseudo-nodules	4.3.6.13
PSOBM	Pseudo oil-based mud	2.2.1
Psoo	Rounded particles, pseudooids	4.3.1.6
PT	Production test	2.1.2.2; 2.2.6; 2.2.8.1
PTS	Pressure Temperature Sonde	1.3.2
pu	purple	4.3.3.1
Px	Pyroxene	4.3.4
PY-zone/zonation	Palynological zone/zonation	4.4.2.2
Pyr	Pyrite	4.3.4
Pyrcl	Pyroclastic rocks	4.2.8.3
Q		
Qz	Quartz	4.2.2.1; 4.3.4
Qzt	Quartzite	4.2.9
R		
R	Repair	2.1.2.3
r	Resistivity	2.2.6
Rad	Radiolaria	4.3.5.2
rain-Imp	Raindrop imprints	4.3.6.13
Rauhw	Rauhwacke	4.3.7.2
Redbd	Red beds	4.3.7.1
repl Por	Replacement porosity	4.3.2.2
RES	Resistivity	1.3.2
Ret	Returns	2.1.2.2; 2.2.8.1
rex	recrystallized	4.2.3.1
RFS	Repeat Formation Sampler	1.3.2
RFT	Repeat Formation Tester	1.3.2
RH	Round holes (completion)	2.2.4
RHAC	Rod pump, heavy walled barrel, top anchor, cup type	2.2.4
RI	Rhyolite	4.2.8.3
(rnd)	subrounded	4.3.1.3
rnd	rounded	4.3.1.3
<u>rnd</u>	well rounded	4.3.1.3
RPS	Retrograding (backstepping) parasequence set	4.4.4
RSE	Regressive surface of erosion	4.4.4
Rud	Rudists	4.3.5.2
S		
S	Salt	4.7.7.1
S	Sample	2.2.6
S	Sand	4.2.2.2
s	sandy	4.2.2.2
S	Scratcher(s)	2.2.3
S	Slim hole	2.1.2.7; 2.2.1
S	stuck (casing)	2.2.3
S	sucrosic	4.2.3.1
S-zone/zonation	Sporomorph zone/zonation	4.4.2.2
salt-Mld	Salt moulds or hoppers	4.3.6.13
SB	Sequence boundary	4.4.4
SBM	Single buoy mooring	3.4.4
SC	Stage collar	2.2.3
SC SSSV	Surface controlled subsurface safety valve	2.2.4
Sch	Schist	4.2.9
Sch, mic	Mica-schist	4.2.9
Sct	Silicilyte, silicilith	4.2.7
SDTR	Sidetrack	2.1.3; 2.2.1
Sel	Selenite	4.3.4
SF	Sand-frac	2.2.5
SH	Structure hole	2.1.2.7
Sh	Shale	4.2.2.2
sh	shaled out	2.1.2.6
SHDT	Stratigraphic High-Resolution Dipmeter	1.3.2

Shelt Por	Shelter porosity	4.3.2.1
SI	Steam injection	2.1.2.3
SIBHP/x min	Shut in bottom hole pressure after x minutes	2.2.6
si-Conc	Siliceous concretions	4.3.7.3
Sid	Siderite	4.3.4
sid-Conc	Siderite concretions or nodules	4.3.7.3
SIOCM	Slightly oil cut mud	2.2.6
sks	slickenside, slickensided	4.3.7.1
SI	Slate	4.2.9
Slt	Silt	4.2.2.2; 4.3.1.1
Sltst	Siltstone	4.2.2.2
slump	slumped	4.3.6.12
sol Por	Solution porosity	4.3.2.2
SON	Sonic travel time	1.3.2
SP	Screw pump	2.1.2.3
SP	Shot point	6.1.1
SP	Spontaneous Potential	1.3.2
(sph)	slightly spherical	4.3.1.4
sph	spherical	4.3.1.4
sph	very spherical	4.3.1.4
Spic	Spicules	4.3.5.2
SPM	Side pocket mandrel	2.2.4
Spr	Sporomorphs	4.3.5.2
Sq C	squeeze cemented	2.2.3
SR	Source rocks	5.1.1
Srf, bor	Bored surface	4.3.5.3
((srt))	very poorly sorted	4.3.1.2
(srt)	poorly sorted	4.3.1.2
srt	moderately well sorted	4.3.1.2
<u>srt</u>	well sorted	4.3.1.2
<u><u>srt</u></u>	very well sorted	4.3.1.2
SS	Saw slots	2.2.4
SS	Site survey	2.1.2.7
SSD	Sliding side door	2.2.4
Sst	Sandstone	4.2.2.2
stltc Por	Stylolitic porosity	4.3.2.2
stri-Cs	Striation casts	4.3.6.13
strm-Lin	Streaming lineation	4.3.6.11
Strom	Stromatoporoids	4.3.5.2
Su	Sulphur	4.3.4
suc	sucrosic	4.2.3.1
Supgp	Supergroup	4.4.1.1
SV	Service well	2.1.2.7
Sv	Sylvinite	4.2.5
Sw	swabbed	2.2.6
SWC	Sidewall core	2.1.2.2; 2.2.8.1; 2.2.8.5
SWCM	Salt water cut mud	2.2.6
SWS	Sidewall sample	2.1.2.2; 2.2.8.1; 2.2.8.5
Sy	Syenite	4.2.8.1
sym-Rpl	Symmetrical ripples	4.3.6.7
T		
T	Tar, bitumen shows	2.1.2.2
T	thermal (gas)	2.2.8.1
TAME	Thermally activated mud emulsion	2.2.1
TC	Top cement	2.2.3
TD	Total depth	2.1.2.1
TDT	Thermal (Neutron) Decay Time Log	1.3.2
Tf	Tuff	4.2.8.3
Tf, weld	Welded tuff, ignimbrite	4.2.8.3
TH	thermal (gas): humic source	2.2.8.1
TH	Tubing pump, heavy walled	2.2.4

Tilt	Tillite, diamictite	4.2.2.2
Tin	Tintinnids	4.3.5.2
TK	thermal (gas): kerogenous source	2.2.8.1
tk-bd	thick bedded	4.3.6.1
TL	Temperature Log	1.3.2
tn-bd	thin bedded	4.3.6.1
Tng	Tongue	4.4.1.1
TOL	Top of liner	2.2.3
transl	translucent	4.3.3.1
Tril	Trilobites	4.3.5.2
TS	Temperature survey	2.1.2.2; 2.2.3; 2.2.8.1
TS	Transgressive surface	4.4.4
TSE	Transgressive surface of erosion, ravinement surface	4.4.4
TST	Transgressive systems tract	4.4.4
TV	true vertical	2.1.3
TVD	True vertical depth	App. 6
TVDSS	True vertical depth subsea	1.3.1; 1.3.3; 2.1.5; App. 5
TWT	Two-way time	6.1.3.1
Ty	Tachydrite	4.2.5
U		
U	Unconformity	2.1.2.6; 4.4.1.2; 4.4.5.1
U; u	Upper; upper	4.4.1.1; 4.4.3
U/B	underbalanced	2.2.1
UBAT	upper bathyal	4.5.1.1
UCP	Upper coastal plain	4.5.1.1
unbd	Massive bedding	4.3.6.2
uncons	unconsolidated	4.3.7.1
unimod srt	unimodally sorted	4.3.1.2
V		
Varv	Varves	4.3.6.8
vgt	variegated	4.3.3.2
Vn	Sedimentary vein	4.3.6.12
Vo	Volcanic rocks, volcanic	4.2.8.3; 4.7.7.1
VR	Vitrinite reflectance	5.2.1
vr-bd	variable bedded	4.3.6.1
VR/E	Vitrinite reflectance/estimated	5.2.1
VR/M	Vitrinite reflectance/measured	5.2.1
Vrtb	Vertebrates	4.3.5.2
VSP	Vertical seismic profile	6.1.4
vug	vuggy, vugular	4.3.2.2
vug Por	Vuggy, vugular porosity	4.3.2.2
W		
W	Lime wackestone	4.2.3.1
W	Water	2.1.2.3; 2.2.6
WBM	Water-based mud	2.2.1
WC	Water cushion	2.2.6
WCM	Water cut mud	2.2.6
WCTS	Water cushion to surface	2.2.6
Wd, si	Silicified wood	4.3.5.2
Wdg	Wedge-shaped layer, tongue	4.3.6.5
WDT	Water down to	2.4
weath	weathered	4.3.7.1
WFT	Wireline formation tester	2.1.2.2
wh	white	4.3.3.1
WI	Water injection	2.1.2.3
Wkst	Lime wackestone	4.2.3.1
WLBP	Wireline bridge plug	2.2.3
WO	wedged out	2.1.2.6

WP	Water producer	2.1.2.3
WS	Well shoot	6.1.4
WUT	Water up to	2.4
WW	Wire wrapped screen	2.2.4
WWS	Wire wrapped screen	2.2.4
X		
X	crystalline	4.2.3.1
xbd	Cross-bedding (non-directional)	4.3.6.6
xbd-c	Chevron/herringbone type cross-bedding	4.3.6.6
xbd-f	Festoon cross-bedding	4.3.6.6
xbd-hm	Hummocky cross-stratification	4.3.6.6
xbd-p	Planar cross-bedding	4.3.6.6
xbd-r	Ripple-drift, climbing ripples	4.3.6.6
xbd-s	Swaley cross-stratification	4.3.6.6
xbd-tb	Tabular cross-bedding	4.3.6.6
xbd-tr	Trough cross-bedding	4.3.6.6
XI	Crystal	4.3.4
xln	crystalline	4.2.3.1
Y		
yel	yellow	4.3.3.1

Appendix 1: Chronostratigraphical Units, Ordered by Age

Chronostratigraphical Units	Abbreviation	Age (Ma)		Duration (Ma)	Hierarchy
		Top	Base		
Phanerozoic	PHAN	0	570.0	570.0	Eonothem
Cenozoic	CZ	0	65.0	65.0	Erathem
Quaternary	QQ	0	1.64	1.64	System
Holocene	HO	0	0.01	0.01	Series
Pleistocene	PS	0.01	1.64	1.63	Series
Milazzian	MLZ	0.01	0.5	0.49	Stage
Sicilian	SI	0.5	0.81	0.31	Stage
Emilian	EN	0.81	1.1	0.29	Stage
Calabrian	CB	1.1	1.64	0.54	Stage
Tertiary	TT	1.64	65.0	63.4	System
Neogene	TU	1.64	23.3	21.7	Subsystem
Pliocene	PI	1.64	5.2	3.6	Series
Pliocene Upper	PIU	1.64	3.4	1.8	Subseries
Piacenzian	PA	1.64	3.4	1.8	Stage
Pliocene Lower	PIL	3.4	5.2	1.8	Subseries
Zanclian	ZC	3.4	5.2	1.8	Stage
Miocene	MI	5.2	23.3	18.1	Series
Miocene Upper	MIU	5.2	10.4	5.2	Subseries
Messinian	ME	5.2	6.7	1.5	Stage
Tortonian	TN	6.7	10.4	3.7	Stage
Miocene Middle	MIM	10.4	16.3	5.9	Subseries
Serravallian	SV	10.4	14.2	3.8	Stage
Langhian	LH	14.2	16.3	2.1	Stage
Miocene Lower	MIL	16.3	23.3	7.0	Subseries
Burdigalian	BU	16.3	21.5	5.2	Stage
Aquitanian	AQ	21.5	23.3	1.8	Stage
Palaeogene	TL	23.3	65.0	41.7	Subsystem
Oligocene	OL	23.3	35.4	12.1	Series
Oligocene Upper	OLU	23.3	29.3	6.0	Subseries
Chattian	CH	23.3	29.3	6.0	Stage
Oligocene Lower	OLL	29.3	35.4	6.1	Subseries
Rupelian	RP	29.3	35.4	6.1	Stage
Eocene	EO	35.4	56.5	21.1	Series
Eocene Upper	EOU	35.4	38.6	3.2	Subseries
Priabonian	PR	35.4	38.6	3.2	Stage
Eocene Middle	EOM	38.6	50.0	11.4	Subseries
Bartonian	BART	38.6	42.1	3.5	Stage
Lutetian	LT	42.1	50.0	7.9	Stage
Eocene Lower	EOL	50.0	56.5	6.5	Subseries
Ypresian	YP	50.0	56.5	6.5	Stage
Paleocene	PC	56.5	65.0	8.5	Series
Paleocene Upper	PCU	56.5	60.5	4.0	Subseries
Selandian	SELA	56.5	60.5	4.0	Stage
Landenian	LN	56.5	58.5	2.0	Regional Stage
Montian	MT	58.5	60.5	2.0	Regional Stage
Paleocene Lower	PCL	60.5	65.0	4.5	Subseries
Danian	DA	60.5	65.0	4.5	Stage

Chronostratigraphical Units	Abbreviation	Age (Ma)		Duration (Ma)	Hierarchy
		Top	Base		
Mesozoic	MZ	65.0	245.0	180.0	Erathem
Cretaceous	KK	65.0	145.0	80.0	System
Cretaceous Upper	KU	65.0	97.0	32.0	Series
Senonian	SE	65.0	88.5	23.5	Subseries
Maastrichtian	MA	65.0	74.0	9.0	Stage
Campanian	CA	74.0	83.0	9.0	Stage
Santonian	SA	83.0	86.5	3.5	Stage
Coniacian	CO	86.5	88.5	2.0	Stage
Turonian	TR	88.5	90.5	2.0	Stage
Cenomanian	CE	90.5	97.0	6.5	Stage
Cretaceous Lower	KL	97.0	145.0	48.0	Series
Albian	AB	97.0	112.0	15.0	Stage
Aptian	AP	112.0	124.5	12.5	Stage
Barremian	BR	124.5	132.0	7.5	Stage
Neocomian	NC	132.0	145.5	13.5	Subseries
Hauterivian	HT	132.0	135.0	3.0	Stage
Valanginian	VA	135.0	140.5	5.5	Stage
Berriasian	BE	140.5	145.5	5.0	Stage
Ryazanian	RYAZ	140.5	142.8	2.3	Regional Stage
Volgian	VOLG	142.8	152.1	9.3	Regional Stage
Jurassic	JJ	145.5	208.0	62.5	System
Jurassic Upper	JU	145.5	157.1	11.6	Series
Tithonian	TI	145.5	152.1	6.6	Stage
Portlandian	PT	145.5	147.5	2.0	Regional Stage
Kimmeridgian	KI	152.1	154.7	2.6	Stage
Oxfordian	OX	154.7	157.1	2.4	Stage
Jurassic Middle	JM	157.1	178.0	20.9	Series
Callovian	CN	157.1	161.3	4.2	Stage
Bathonian	BT	161.3	166.1	4.8	Stage
Bajocian	BJ	166.1	173.5	7.4	Stage
Aalenian	AA	173.5	178.0	4.5	Stage
Jurassic Lower	JL	178.0	208.0	30.0	Series
Toarcian	TC	178.0	187.0	9.0	Stage
Pliensbachian	PB	187.0	194.5	7.5	Stage
Sinemurian	SM	194.5	203.5	9.0	Stage
Hettangian	HE	203.5	208.0	4.5	Stage
Triassic	RR	208.0	245.0	37.0	System
Triassic Upper	RU	208.0	235.0	27.0	Series
Rhaetian	RH	208.0	210.0	2.0	Stage
Norian	NO	210.0	223.0	13.0	Stage
Sevastian	SEVA	210.0	212.0	2.0	Substage
Alaunian	ALAU	212.0	217.5	5.5	Substage
Lacian	LACI	217.5	223.0	5.5	Substage
Carnian	CR	223.0	235.0	12.0	Stage
Tuvalian	TUVA	223.0	229.0	6.0	Substage
Julian	JULI	229.0	233.0	4.0	Substage
Cordevolian	CORD	233.0	235.0	2.0	Substage
Triassic Middle	RM	235.0	241.0	6.0	Series
Ladinian	LA	235.0	239.5	4.5	Stage
Langobardian	LANG	235.0	237.5	2.5	Substage
Fassanian	FASS	237.5	239.5	2.0	Substage
Anisian	AN	239.5	241.0	1.5	Stage
Illyrian	ILLY	239.5	240.0	0.5	Substage
Pelsonian	PELS	240.0	240.3	0.3	Substage
Bithynian	BITH	240.3	240.7	0.4	Substage
Aegean	AEGE	240.7	241.0	0.3	Substage
Triassic Lower	RL	241.0	245.0	4.0	Series
Scythian	SK	241.0	245.0	4.0	Stage

Chronostratigraphical Units	Abbreviation	Age (Ma)		Duration (Ma)	Hierarchy
		Top	Base		
Spathian	SPAT	241.0	242.0	1.0	Substage
Nammalian	NAMM	242.0	243.5	1.5	Substage
Smithian	SMIT	242.0	243.0	1.0	Substage
Dienerian	DIEN	243.0	243.5	0.5	Substage
Griesbachian	GRIE	243.5	245.0	1.5	Substage
Palaeozoic	PZ	245.0	570.0	325.0	Erathem
Permian	PP	245.0	290.0	45.0	System
Permian Upper	PU	245.0	256.0	11.0	Series
Changxingian	CHAN	245.0	247.5	2.5	Stage
Dorashamian	DORA	245.0	247.5	2.5	Regional Stage
Tatarian	TA	245.0	251.0	6.0	Regional Stage
Thuringian	THUR	245.0	255.0	10.0	Regional Stage
Longtanian	LONG	247.5	250.0	2.5	Stage
Dzhulfian	DZHV	247.5	249.5	2.0	Regional Stage
Abadehian	ABAD	249.5	252.5	3.0	Regional Stage
Capitanian	CAPI	250.0	252.5	2.5	Stage
Kazanian	KA	251.0	255.0	4.0	Regional Stage
Wordian	WORD	252.5	255.0	2.5	Stage
Murghabian	MURG	252.5	255.0	2.5	Regional Stage
Ufimian	UFIM	255.0	256.0	1.0	Stage
Kubergandian	KUBE	255.0	260.0	5.0	Regional Stage
Permian Lower	PL	256.0	290.0	34.0	Series
Kungurian	KG	256.0	260.0	4.0	Stage
Artinskian	AT	260.0	269.0	9.0	Stage
Sakmarian	SR	269.0	282.0	13.0	Stage
Asselian	AE	282.0	290.0	8.0	Stage
Carboniferous	CC	290.0	363.0	73.0	System
Pennsylvanian	PENN	290.0	323.0	33.0	Subsystem
Carboniferous Upper	CU	290.0	303.0	13.0	Series
Gzhelian	GZ	290.0	295.0	5.0	Stage
Stephanian	ST	290.0	304.0	14.0	Regional Stage
Stephanian C	STC	290.0	294.0	4.0	Regional Substage
Noginskian	NOGI	290.0	293.5	3.5	Substage
Klazminskian	KLAZ	293.5	295.0	1.5	Substage
Stephanian B	STB	294.0	298.0	4.0	Regional Substage
Kasimovian	KASI	295.0	303.0	8.0	Stage
Dorogomilovskian	DORO	295.0	298.5	3.5	Substage
Stephanian A	STA	298.0	304.0	6.0	Regional Substage
Chamovnicheskian	CHAM	298.5	300.0	1.5	Substage
Krevyankian	KREV	300.0	303.0	3.0	Substage
Cantabrian	CTB	300.0	304.0	4.0	Regional Stage
Carboniferous Middle	CM	303.0	323.0	20.0	Series
Moscovian	MO	303.0	311.0	8.0	Stage
Myachkovskian	MYAC	303.0	305.0	2.0	Substage
Westphalian	WP	304.0	317.0	13.0	Regional Stage
Westphalian D	WPD	304.0	306.0	2.0	Regional Substage
Podolskian	PODO	305.0	307.0	2.0	Substage
Westphalian C	WPC	306.0	309.0	3.0	Regional Substage
Kashirskian	KASH	307.0	309.0	2.0	Substage
Vereiskian	VERE	309.0	311.0	2.0	Substage
Westphalian B	WPB	309.0	312.0	3.0	Regional Substage
Bashkirian	BA	311.0	323.0	12.0	Stage
Melekesskian	MELE	311.0	313.5	2.5	Substage
Westphalian A	WPA	312.0	317.0	5.0	Regional Substage
Cheremshanskian	CHER	313.5	318.5	5.0	Substage
Namurian	NM	317.0	333.0	16.0	Regional Stage
Namurian C	NMC	317.0	320.0	3.0	Regional Substage
Yeadonian	YEAD	318.5	320.5	2.0	Substage

Chronostratigraphical Units	Abbreviation	Age (Ma)		Duration (Ma)	Hierarchy
		Top	Base		
Namurian B	NMB	320.0	323.0	3.0	Regional Substage
Marsdenian	MRSD	320.5	321.5	1.0	Substage
Kinderscoutian	KIND	321.5	323.0	1.5	Substage
Mississippian	MISS	323.0	363.0	40.0	Subsystem
Carboniferous Lower	CL	323.0	363.0	40.0	Series
Serpukhovian	SERP	323.0	333.0	10.0	Stage
Namurian A	NMA	323.0	333.0	10.0	Regional Substage
Alportian	ALPO	323.0	325.5	2.5	Substage
Chokierian	CHOK	325.5	328.5	3.0	Substage
Arnsbergian	ARNS	328.5	331.0	2.5	Substage
Pendleian	PEND	331.0	333.0	2.0	Substage
Visean	VI	333.0	350.0	17.0	Stage
Brigantian	BRIG	333.0	336.0	3.0	Substage
Asbian	ASHI	336.0	339.5	3.5	Substage
Holkerian	HOLK	339.5	343.0	3.5	Substage
Arundian	ARUN	343.0	345.0	2.0	Substage
Chadian	CHAD	345.0	350.0	5.0	Substage
Tournaisian	TO	350.0	363.0	13.0	Stage
Ivorian	IVOR	350.0	354.0	4.0	Substage
Hastarian	HAST	354.0	363.0	9.0	Substage
Devonian	DD	363.0	409.0	46.0	System
Devonian Upper	DU	363.0	377.0	14.0	Series
Famennian	FA	363.0	367.0	4.0	Stage
Frasnian	FS	367.0	377.0	10.0	Stage
Devonian Middle	DM	377.0	386.0	9.0	Series
Givetian	GI	377.0	381.0	4.0	Stage
Eifelian	EIF	381.0	386.0	5.0	Stage
Devonian Lower	DL	386.0	409.0	23.0	Series
Emsian	ES	386.0	390.0	4.0	Stage
Pragian	PRAG	390.0	396.0	6.0	Stage
Siegenian	SG	390.0	396.0	6.0	Regional Stage
Lochkovian	LOCH	396.0	409.0	13.0	Stage
Gedinnian	GD	396.0	409.0	13.0	Regional Stage
Silurian	SS	409.0	439.0	30.0	System
Silurian Upper	SU	409.0	424.0	15.0	Subsystem
Pridoli	PD	409.0	411.0	2.0	Series
Ludlow	LD	411.0	424.0	13.0	Series
Ludfordian	LUDF	411.0	415.0	4.0	Stage
Gorstian	GORS	415.0	424.0	9.0	Stage
Silurian Lower	SL	424.0	439.0	15.0	Subsystem
Wenlock	WN	424.0	430.0	6.0	Series
Homerian	HOME	424.0	426.0	2.0	Stage
Sheinwoodian	SHEI	426.0	430.0	4.0	Stage
Llandoverly	LO	430.0	439.0	9.0	Series
Telychian	TELY	430.0	433.0	3.0	Stage
Aeronian	AERO	433.0	437.0	4.0	Stage
Rhuddanian	RHUD	437.0	439.0	2.0	Stage
Ordovician	OO	439.0	510.0	71.0	System
Ordovician Upper	OOU	439.0	464.0	25.0	Subsystem
Ashgill	AS	439.0	443.0	4.0	Series
Hirnantian	HIRN	439.0	439.5	0.5	Stage
Rawtheyan	RAWT	439.5	440.0	0.5	Stage
Cautleyan	CAUT	440.0	441.0	1.0	Stage
Pusgillian	PUSG	441.0	443.0	2.0	Stage
Caradoc	CD	443.0	464.0	21.0	Series
Onnian	ONNI	443.0	444.0	1.0	Stage
Actonian	ACTO	444.0	445.0	1.0	Stage
Marshbrookian	MARS	445.0	447.0	2.0	Stage

Chronostratigraphical Units	Abbreviation	Age (Ma)		Duration (Ma)	Hierarchy
		Top	Base		
Longvillian	LNGV	447.0	450.0	3.0	Stage
Soudleyan	SODU	450.0	458.0	8.0	Stage
Harnagian	HARN	458.0	462.0	4.0	Stage
Costonian	COST	462.0	464.0	2.0	Stage
Ordovician Middle	OOM	464.0	476.0	12.0	Subsystem
Llandeilo	LE	464.0	469.0	5.0	Series
Llandeilo Upper	LEU	464.0	466.0	2.0	Subseries
Llandeilo Middle	LEM	466.0	467.0	1.0	Subseries
Llandeilo Lower	LEL	467.0	469.0	2.0	Subseries
Llanvirn	LI	469.0	476.0	7.0	Series
Llanvirn Upper	LIU	469.0	473.0	4.0	Subseries
Llanvirn Lower	LIL	473.0	476.0	3.0	Subseries
Ordovician Lower	OOL	476.0	510.0	34.0	Subsystem
Arenig	AR	476.0	493.0	17.0	Series
Tremadoc	TM	493.0	510.0	17.0	Series
Cambrian	EE	510.0	570.0	60.0	System
Cambrian Upper	EEU	510.0	517.0	7.0	Series
Dolgellian	DOLG	510.0	514.0	4.0	Stage
Maentwrogian	MAEN	514.0	517.0	3.0	Stage
Cambrian Middle	EEM	517.0	536.0	19.0	Series
Menevian	MENE	517.0	530.0	13.0	Stage
Solvanian	SOLV	530.0	536.0	6.0	Stage
Cambrian Lower	EEL	536.0	570.0	34.0	Series
Lenian	LENI	536.0	554.0	18.0	Stage
Atdabanian	ATDA	554.0	560.0	6.0	Stage
Tommotian	TOMM	560.0	570.0	10.0	Stage
Proterozoic	ZO	570.0	2500.0	1930.0	Eonothem
Proterozoic Upper	ZOU	570.0	900.0	330.0	Subeonothem
Sinian	SINI	570.0	800.0	230.0	Erathem
Vendian	VEND	570.0	610.0	40.0	System
Ediacara	EDIA	570.0	590.0	20.0	Series
Poundian	POUN	570.0	580.0	10.0	Stage
Wonokanian	WONO	580.0	590.0	10.0	Stage
Varanger	VARA	590.0	610.0	20.0	Series
Mortensnes	MORT	590.0	600.0	10.0	Stage
Smalfjord	SMAL	600.0	610.0	10.0	Stage
Sturtian	STUR	610.0	800.0	190.0	System
Riphaean	RIPH	800.0	1650.0	850.0	Erathem
Proterozoic Middle	ZOM	900.0	1650.0	750.0	Subeonothem
Proterozoic Lower	ZOL	1650.0	2500.0	850.0	Subeonothem
Archaean	ZA	2500.0	4000.0	1500.0	Eonothem
Hadean	HADE	4000.0	4550.0	550.0	Eonothem

Appendix 2: Chronostratigraphical Units, Alphabetical

Chronostratigraphical Units	Abbreviation	Age (Ma)		Duration (Ma)	Hierarchy
		Top	Base		
Aalenian	AA	173.5	178.0	4.5	Stage
Abadehian	ABAD	249.5	252.5	3.0	Regional Stage
Actonian	ACTO	444.0	445.0	1.0	Stage
Aegean	AEGE	240.7	241.0	0.3	Substage
Aeronian	AERO	433.0	437.0	4.0	Stage
Alaunian	ALAU	212.0	217.5	5.5	Substage
Albian	AB	97.0	112.0	15.0	Stage
Alportian	ALPO	323.0	325.5	2.5	Substage
Anisian	AN	239.5	241.0	1.5	Stage
Aptian	AP	112.0	124.5	12.5	Stage
Aquitanian	AQ	21.5	23.3	1.8	Stage
Archaean	ZA	2500.0	4000.0	1500.0	Eonothem
Arenig	AR	476.0	493.0	17.0	Series
Arnsbergian	ARNS	328.5	331.0	2.5	Substage
Artinskian	AT	260.0	269.0	9.0	Stage
Arundian	ARUN	343.0	345.0	2.0	Substage
Ashgill	AS	439.0	443.0	4.0	Series
Asbian	ASHI	336.0	339.5	3.5	Substage
Asselian	AE	282.0	290.0	8.0	Stage
Atdabanian	ATDA	554.0	560.0	6.0	Stage
Bajocian	BJ	166.1	173.5	7.4	Stage
Barremian	BR	124.5	132.0	7.5	Stage
Bartonian	BART	38.6	42.1	3.5	Stage
Bashkirian	BA	311.0	323.0	12.0	Stage
Bathonian	BT	161.3	166.1	4.8	Stage
Berriasian	BE	140.5	145.5	5.0	Stage
Bithynian	BITH	240.3	240.7	0.4	Substage
Brigantian	BRIG	333.0	336.0	3.0	Substage
Burdigalian	BU	16.3	21.5	5.2	Stage
Calabrian	CB	1.1	1.64	0.54	Stage
Callovian	CN	157.1	161.3	4.2	Stage
Cambrian	EE	510.0	570.0	60.0	System
Cambrian Lower	EEL	536.0	570.0	34.0	Series
Cambrian Middle	EEM	517.0	536.0	19.0	Series
Cambrian Upper	EEU	510.0	517.0	7.0	Series
Campanian	CA	74.0	83.0	9.0	Stage
Cantabrian	CTB	300.0	304.0	4.0	Regional Stage
Capitanian	CAPI	250.0	252.5	2.5	Stage
Caradoc	CD	443.0	464.0	21.0	Series
Carboniferous	CC	290.0	363.0	73.0	System
Carboniferous Lower	CL	323.0	363.0	40.0	Series
Carboniferous Middle	CM	303.0	323.0	20.0	Series
Carboniferous Upper	CU	290.0	303.0	13.0	Series
Carnian	CR	223.0	235.0	12.0	Stage
Cautleyan	CAUT	440.0	441.0	1.0	Stage
Cenomanian	CE	90.5	97.0	6.5	Stage
Cenozoic	CZ	0.0	65.0	65.0	Erathem
Chadian	CHAD	345.0	350.0	5.0	Substage
Chamovnicheskian	CHAM	298.5	300.0	1.5	Substage
Changxingian	CHAN	245.0	247.5	2.5	Stage
Chattian	CH	23.3	29.3	6.0	Stage
Cheremshanskian	CHER	313.5	318.5	5.0	Substage
Chokierian	CHOK	325.5	328.5	3.0	Substage
Coniacian	CO	86.5	88.5	2.0	Stage
Cordevolian	CORD	233.0	235.0	2.0	Substage
Costonian	COST	462.0	464.0	2.0	Stage
Cretaceous	KK	65.0	145.0	80.0	System

Chronostratigraphical Units	Abbreviation	Age (Ma)		Duration (Ma)	Hierarchy
		Top	Base		
Cretaceous Lower	KL	97.0	145.5	48.5	Series
Cretaceous Upper	KU	65.0	97.0	32.0	Series
Danian	DA	60.5	65.0	4.5	Stage
Devonian	DD	363.0	409.0	46.0	System
Devonian Lower	DL	386.0	409.0	23.0	Series
Devonian Middle	DM	377.0	386.0	9.0	Series
Devonian Upper	DU	363.0	377.0	14.0	Series
Dienerian	DIEN	243.0	243.5	0.5	Substage
Dolgellian	DOLG	510.0	514.0	4.0	Stage
Dorashamian	DORA	245.0	247.5	2.5	Regional Stage
Dorogomilovskian	DORO	295.0	298.5	3.5	Substage
Dzhulfian	DZHV	247.5	249.5	2.0	Regional Stage
Ediacara	EDIA	570.0	590.0	20.0	Series
Eifelian	EIF	381.0	386.0	5.0	Stage
Emilian	EN	0.81	1.1	0.29	Stage
Emsian	ES	386.0	390.0	4.0	Stage
Eocene	EO	35.4	56.5	21.1	Series
Eocene Lower	EOL	50.0	56.5	6.5	Subseries
Eocene Middle	EOM	38.6	50.0	11.4	Subseries
Eocene Upper	EOU	35.4	38.6	3.2	Subseries
Famennian	FA	363.0	367.0	4.0	Stage
Fassanian	FASS	237.5	239.5	2.0	Substage
Frasnian	FS	367.0	377.0	10.0	Stage
Gedinnian	GD	396.0	409.0	13.0	Regional Stage
Givetian	GI	377.0	381.0	4.0	Stage
Gorstian	GORS	415.0	424.0	9.0	Stage
Griesbachian	GRIE	243.5	245.0	1.5	Substage
Gzhelian	GZ	290.0	295.0	5.0	Stage
Hadean	HADE	4000.0	4550.0	550.0	Eonothem
Harnagian	HARN	458.0	462.0	4.0	Stage
Hastarian	HAST	354.0	363.0	9.0	Substage
Hauterivian	HT	132.0	135.0	3.0	Stage
Hettangian	HE	203.5	208.0	4.5	Stage
Hirnantian	HIRN	439.0	439.5	0.5	Stage
Holkerian	HOLK	339.5	343.0	3.5	Substage
Holocene	HO	0.0	0.01	0.01	Series
Homerian	HOME	424.0	426.0	2.0	Stage
Illyrian	ILLY	239.5	240.0	0.5	Substage
Ivorian	IVOR	350.0	354.0	4.0	Substage
Julian	JULI	229.0	233.0	4.0	Substage
Jurassic	JJ	145.5	208.0	62.5	System
Jurassic Lower	JL	178.0	208.0	30.0	Series
Jurassic Middle	JM	157.1	178.0	20.9	Series
Jurassic Upper	JU	145.5	157.1	11.6	Series
Kashirskian	KASH	307.0	309.0	2.0	Substage
Kazanian	KA	251.0	255.0	4.0	Regional Stage
Kasimovian	KASI	295.0	303.0	8.0	Stage
Kimmeridgian	KI	152.1	154.7	2.6	Stage
Kinderscoutian	KIND	321.5	323.0	1.5	Substage
Klazminskian	KLAZ	293.5	295.0	1.5	Substage
Krevyakinian	KREV	300.0	303.0	3.0	Substage
Kubergandian	KUBE	255.0	260.0	5.0	Regional Stage
Kungurian	KG	256.0	260.0	4.0	Stage

Chronostratigraphical Units	Abbreviation	Age (Ma)		Duration (Ma)	Hierarchy
		Top	Base		
Lacian	LACI	217.5	223.0	5.5	Substage
Ladinian	LA	235.0	239.5	4.5	Stage
Landenian	LN	56.5	58.5	2.0	Regional Stage
Langhian	LH	14.2	16.3	2.1	Stage
Langobardian	LANG	235.0	237.5	2.5	Substage
Lenian	LENI	536.0	554.0	18.0	Stage
Llandeilo	LE	464.0	469.0	5.0	Series
Llandeilo Lower	LEL	467.0	469.0	2.0	Subseries
Llandeilo Middle	LEM	466.0	467.0	1.0	Subseries
Llandeilo Upper	LEU	464.0	466.0	2.0	Subseries
Llandovery	LO	430.0	439.0	9.0	Series
Llanvirn	LI	469.0	476.0	7.0	Series
Llanvirn Lower	LIL	473.0	476.0	3.0	Subseries
Llanvirn Upper	LIU	469.0	473.0	4.0	Subseries
Lochkovian	LOCH	396.0	409.0	13.0	Stage
Longtanian	LONG	247.5	250.0	2.5	Stage
Longvillian	LNGV	447.0	450.0	3.0	Stage
Ludfordian	LUDF	411.0	415.0	4.0	Stage
Ludlow	LD	411.0	424.0	13.0	Series
Lutetian	LT	42.1	50.0	7.9	Stage
Maastrichtian	MA	65.0	74.0	9.0	Stage
Maentwrogian	MAEN	514.0	517.0	3.0	Stage
Marsdenian	MRSD	320.5	321.5	1.0	Substage
Marshbrookian	MARS	445.0	447.0	2.0	Stage
Melekesskian	MELE	311.0	313.5	2.5	Substage
Menevian	MENE	517.0	530.0	13.0	Stage
Mesozoic	MZ	65.0	245.0	180.0	Erathem
Messinian	ME	5.2	6.7	1.5	Stage
Milazzian	MLZ	0.01	0.5	0.49	Stage
Miocene	MI	5.2	23.3	18.1	Series
Miocene Lower	MIL	16.3	23.3	7.0	Subseries
Miocene Middle	MIM	10.4	16.3	5.9	Subseries
Miocene Upper	MIU	5.2	10.4	5.2	Subseries
Mississippian	MISS	323.0	363.0	40.0	Subsystem
Montian	MT	58.5	60.5	2.0	Regional Stage
Mortensnes	MORT	590.0	600.0	10.0	Stage
Moscovian	MO	303.0	311.0	8.0	Stage
Murghabian	MURG	252.5	255.0	2.5	Regional Stage
Myachkovskian	MYAC	303.0	305.0	2.0	Substage
Nammalian	NAMM	242.0	243.5	1.5	Substage
Namurian	NM	317.0	333.0	16.0	Regional Stage
Namurian A	NMA	323.0	333.0	10.0	Regional Substage
Namurian B	NMB	320.0	323.0	3.0	Regional Substage
Namurian C	NMC	317.0	320.0	3.0	Regional Substage
Neocomian	NC	132.0	145.5	13.5	Subseries
Neogene	TU	1.64	23.3	21.7	Subsystem
Noginskian	NOGI	290.0	293.5	3.5	Substage
Norian	NO	210.0	223.0	13.0	Stage
Oligocene	OL	23.3	35.4	12.1	Series
Oligocene Lower	OLL	29.3	35.4	6.1	Subseries
Oligocene Upper	OLU	23.3	29.3	6.0	Subseries
Onnian	ONNI	443.0	444.0	1.0	Stage
Ordovician	OO	439.0	510.0	71.0	System
Ordovician Lower	OOL	476.0	510.0	34.0	Subsystem
Ordovician Middle	OOM	464.0	476.0	12.0	Subsystem
Ordovician Upper	OOU	439.0	464.0	25.0	Subsystem
Oxfordian	OX	154.7	157.1	2.4	Stage

Chronostratigraphical Units	Abbreviation	Age (Ma)		Duration (Ma)	Hierarchy
		Top	Base		
Palaeogene	TL	23.3	65.0	41.7	Subsystem
Paleocene	PC	56.5	65.0	8.5	Series
Paleocene Lower	PCL	60.5	65.0	4.5	Subseries
Paleocene Upper	PCU	56.5	60.5	4.0	Subseries
Paleozoic	PZ	245.0	570.0	325.0	Erathem
Pelsonian	PELS	240.0	240.3	0.3	Substage
Pendleian	PEND	331.0	333.0	2.0	Substage
Pennsylvanian	PENN	290.0	323.0	33.0	Subsystem
Permian	PP	245.0	290.0	45.0	System
Permian Lower	PL	256.0	290.0	34.0	Series
Permian Upper	PU	245.0	256.0	11.0	Series
Phanerozoic	PHAN	0.0	570.0	570.0	Eonothem
Piacenzian	PA	1.64	3.4	1.8	Stage
Pleistocene	PS	0.01	1.64	1.63	Series
Pliensbachian	PB	187.0	194.5	7.5	Stage
Pliocene	PI	1.64	5.2	3.6	Series
Pliocene Lower	PIL	3.4	5.2	1.8	Subseries
Pliocene Upper	PIU	1.64	3.4	1.8	Subseries
Podolskian	PODO	305.0	307.0	2.0	Substage
Portlandian	PT	145.5	147.5	2.0	Regional Stage
Poundian	POUN	570.0	580.0	10.0	Stage
Pragian	PRAG	390.0	396.0	6.0	Stage
Priabonian	PR	35.4	38.6	3.2	Stage
Pridoli	PD	409.0	411.0	2.0	Series
Proterozoic	ZO	570.0	2500.0	1930.0	Eonothem
Proterozoic Lower	ZOL	1650.0	2500.0	850.0	Subeonothem
Proterozoic Middle	ZOM	900.0	1650.0	750.0	Subeonothem
Proterozoic Upper	ZOU	570.0	900.0	330.0	Subeonothem
Pusgillian	PUSG	441.0	443.0	2.0	Stage
Quaternary	QQ	0.0	1.64	1.64	System
Rawtheyan	RAWT	439.5	440.0	0.5	Stage
Rhaetian	RH	208.0	210.0	2.0	Stage
Rhuddanian	RHUD	437.0	439.0	2.0	Stage
Riphaean	RIPH	800.0	1650.0	850.0	Erathem
Rupelian	RP	29.3	35.4	6.1	Stage
Ryazanian	RYAZ	140.5	142.8	2.3	Regional Stage
Sakmarian	SR	269.0	282.0	13.0	Stage
Santonian	SA	83.0	86.5	3.5	Stage
Scythian	SK	241.0	245.0	4.0	Series
Selandian	SELA	56.5	60.5	4.0	Stage
Senonian	SE	65.0	88.5	23.5	Subseries
Serpukhovian	SERP	323.0	333.0	10.0	Stage
Sevastian	SEVA	210.0	212.0	2.0	Substage
Sheinwoodian	SHEI	426.0	430.0	4.0	Stage
Sicilian	SI	0.5	0.81	0.31	Stage
Siegenian	SG	390.0	396.0	6.0	Regional Stage
Silurian	SS	409.0	439.0	30.0	System
Silurian Lower	SL	424.0	439.0	15.0	Subsystem
Silurian Upper	SU	409.0	424.0	15.0	Subsystem
Sinemurian	SM	194.5	203.5	9.0	Stage
Sinian	SINI	570.0	800.0	230.0	Erathem
Smalfjord	SMAL	600.0	610.0	10.0	Stage
Smithian	SMIT	242.0	243.0	1.0	Substage
Solvanian	SOLV	530.0	536.0	6.0	Stage
Soudleyan	SODU	450.0	458.0	8.0	Stage
Spathian	SPAT	241.0	242.0	1.0	Substage
Stephanian	ST	290.0	304.0	14.0	Regional Stage
Stephanian A	STA	298.0	304.0	6.0	Regional Substage

Chronostratigraphical Units	Abbreviation	Age (Ma)		Duration (Ma)	Hierarchy
		Top	Base		
Stephanian B	STB	294.0	298.0	4.0	Regional Substage
Stephanian C	STC	290.0	294.0	4.0	Regional Substage
Sturtian	STUR	610.0	800.0	190.0	System
Tatarian	TA	245.0	251.0	6.0	Regional Stage
Telychian	TELY	430.0	433.0	3.0	Stage
Tertiary	TT	1.64	65.0	63.4	System
Thuringian	THUR	245.0	255.0	10.0	Regional Stage
Tithonian	TI	145.5	152.1	6.6	Stage
Toarcian	TC	178.0	187.0	9.0	Stage
Tommotian	TOMM	560.0	570.0	10.0	Stage
Tortonian	TN	6.7	10.4	3.7	Stage
Tournaisian	TO	350.0	363.0	13.0	Stage
Tremadoc	TM	493.0	510.0	17.0	Series
Triassic	RR	208.0	245.0	37.0	System
Triassic Lower	RL	241.0	245.0	4.0	Series
Triassic Middle	RM	235.0	241.0	6.0	Series
Triassic Upper	RU	208.0	235.0	27.0	Series
Turonian	TR	88.5	90.5	2.0	Stage
Tuvalian	TUVA	223.0	229.0	6.0	Substage
Ufimian	UFIM	255.0	256.0	1.0	Stage
Valanginian	VA	135.0	140.5	5.5	Stage
Varanger	VARA	590.0	610.0	20.0	Series
Vendian	VEND	570.0	610.0	40.0	System 32
Vereiskian	VERE	309.0	311.0	2.0	Substage
Visean	VI	333.0	350.0	17.0	Stage
Volgian	VOLG	142.8	152.1	9.3	Regional Stage
Wenlock	WN	424.0	430.0	6.0	Series
Westphalian	WP	304.0	317.0	13.0	Regional Stage
Westphalian A	WPA	312.0	317.0	5.0	Regional Substage
Westphalian B	WPB	309.0	312.0	3.0	Regional Substage
Westphalian C	WPC	306.0	309.0	3.0	Regional Substage
Westphalian D	WPD	304.0	306.0	2.0	Regional Substage
Wonokanian	WONO	580.0	590.0	10.0	Stage
Wordian	WORD	252.5	255.0	2.5	Stage
Yeadonian	YEAD	318.5	320.5	2.0	Substage
Ypresian	YP	50.0	56.5	6.5	Stage
Zanclian	ZC	3.4	5.2	1.8	Stage























Appendix 3: Chronostratigraphical Units, Abbreviations, Alphabetical





















Abbreviation	Unit	Abbreviation	Unit
AA	Aalenian	DA	Danian
AB	Albian	DD	Devonian
ABAD	Abadehian	DIEN	Dienerian
ACTO	Actonian	DL	Devonian Lower
AE	Asselian	DM	Devonian Middle
AEGE	Aegean	DOLG	Dolgellian
AERO	Aeronian	DORA	Dorashamian
ALAU	Alaunian	DORO	Dorogomilovskian
ALPO	Alportian	DU	Devonian Upper
AN	Anisian	DZHV	Dzhulfian
AP	Aptian		
AQ	Aquitanian	EDIA	Ediacara
AR	Arenig	EE	Cambrian
ARNS	Arnsbergian	EEL	Cambrian Lower
ARUN	Arundian	EEM	Cambrian Middle
AS	Ashgill	EEU	Cambrian Upper
ASHI	Asbian	EIF	Eifelian
AT	Artinskian	EN	Emilian
ATDA	Atdabanian	EO	Eocene
		EOL	Eocene Lower
BA	Bashkirian	EOM	Eocene Middle
BART	Bartonian	EOU	Eocene Upper
BE	Berriasian	ES	Emsian
BITH	Bithynian		
BJ	Bajocian	FA	Famennian
BR	Barremian	FASS	Fassanian
BRIG	Brigantian	FS	Frasnian
BT	Bathonian		
BU	Burdigalian	GD	Gedinnian
		GI	Givetian
CA	Campanian	GORS	Gorstian
CAPI	Capitanian	GRIE	Griesbachian
CAUT	Cautleya	GZ	Gzelian
CB	Calabrian		
CC	Carboniferous	HADE	Hadean
CD	Caradoc	HARN	Harnagian
CE	Cenomanian	HAST	Hastarian
CH	Chattian	HE	Hettangian
CHAD	Chadian	HIRN	Hirnantian
CHAM	Chamovnicheskian	HO	Holocene
CHAN	Changxingian	HOLK	Holkerian
CHER	Cheremshanskian	HOME	Homerian
CHOK	Chokierian	HT	Hauterivian
CL	Carboniferous Lower		
CM	Carboniferous Middle	ILLY	Illyrian
CN	Callovian	IVOR	Ivorian
CO	Coniacian		
CORD	Cordevolian	JJ	Jurassic
COST	Costonian	JL	Jurassic Lower
CR	Carnian	JM	Jurassic Middle
CTB	Cantabrian	JU	Jurassic Upper
CU	Carboniferous Upper	JULI	Julian
CZ	Cenozoic		

Abbreviation	Unit	Abbreviation	Unit
KA	Kazanian	NMA	Namurian A
KASH	Kashirskian	NMB	Namurian B
KASI	Kasimovian	NMC	Namurian C
KG	Kungurian	NO	Norian
KI	Kimmeridgian	NOGI	Noginskian
KIND	Kinderscoutian		
KK	Cretaceous	OL	Oligocene
KL	Cretaceous Lower	OLL	Oligocene Lower
KLAZ	Klazminskian	OLU	Oligocene Upper
KREV	Krevyakinskian	ONNI	Onnian
KU	Cretaceous Upper	OO	Ordovician
KUBE	Kubergandian	OOL	Ordovician Lower
		OOM	Ordovician Middle
		OOU	Ordovician Upper
		OX	Oxfordian
LA	Ladinian	PA	Piacenzian
LACI	Lacian	PB	Pliensbachian
LANG	Langobardian	PC	Paleocene
LD	Ludlow	PCL	Paleocene Lower
LE	Llandeilo	PCU	Paleocene Upper
LEL	Llandeilo Lower	PD	Pridoli
LEM	Llandeilo Middle	PELS	Pelsonian
LENI	Lenian	PEND	Pendleian
LEU	Llandeilo Upper	PENN	Pennsylvanian
LH	Langhian	PHAN	Phanerozoic
LI	Llanvirn	PI	Pliocene
LIL	Llanvirn Lower	PIL	Pliocene Lower
LIU	Llanvirn Upper	PIU	Pliocene Upper
LN	Landenian	PL	Permian Lower
LNGV	Longvillian	PODO	Podolskian
LO	Llandovery	POUN	Poundian
LOCH	Lochkovian	PP	Permian
LONG	Longtanian	PR	Priabonian
LT	Lutetian	PRAG	Pragian
LUDF	Ludfordian	PS	Pleistocene
		PT	Portlandian
MA	Maastrichtian	PU	Permian Upper
MAEN	Maentwrogian	PUSG	Pusgillian
MARS	Marshbrookian	PZ	Paleozoic
ME	Messinian		
MELE	Melekesskian	QQ	Quaternary
MENE	Menevian		
MI	Miocene	RAWT	Rawtheyan
MIL	Miocene Lower	RH	Rhaetian
MIM	Miocene Middle	RHUD	Rhuddanian
MISS	Mississippian	RIPH	Riphaean
MIU	Miocene Upper	RL	Triassic Lower
MLZ	Milazzian	RM	Triassic Middle
MO	Moscovian	RP	Rupelian
MORT	Mortensnes	RR	Triassic
MRSD	Marsdenian	RU	Triassic Upper
MT	Montian	RYAZ	Ryazanian
MURG	Murghabian		
MYAC	Myachkovskian	SA	Santonian
MZ	Mesozoic	SE	Senonian
		SELA	Selandian
NAMM	Nammalian		
NC	Neocomian		
NM	Namurian		

Abbreviation	Unit	Abbreviation	Unit
SERP	Serpukhovian	TOMM	Tommotian
SEVA	Sevastian	TR	Turonian
SG	Siegenian	TT	Tertiary
SHEI	Sheinwoodian	TU	Neogene
SI	Sicilian	TUVA	Tuvalian
SINI	Sinian		
SK	Scythian	UFIM	Ufimian
SL	Silurian Lower		
SM	Sinemurian	VA	Valanginian
SMAL	Smalfjord	VARA	Varanger
SMIT	Smithian	VEND	Vendian
SOLV	Solvanian	VERE	Vereiskian
SOUD	Soudleyan	VI	Visean
SPAT	Spathian	VOLG	Volgian
SR	Sakmarian		
SS	Silurian	WN	Wenlock
ST	Stephanian	WONO	Wonokanian
STA	Stephanian A	WORD	Wordian
STB	Stephanian B	WP	Westphalian
STC	Stephanian C	WPA	Westphalian A
STUR	Sturtian	WPB	Westphalian B
SU	Silurian Upper	WPC	Westphalian C
SV	Serravallian	WPD	Westphalian D
TA	Tatarian	YEAD	Yeadonian
TC	Toarcian	YP	Ypresian
TELY	Telychian		
THUR	Thuringian	ZA	Archaean
TI	Tithonian	ZC	Zanclian
TL	Palaeogene	ZO	Proterozoic
TM	Tremadoc	ZOL	Proterozoic Lower
TN	Tortonian	ZOM	Proterozoic Middle
TO	Tournaisian	ZOU	Proterozoic Upper

Appendix 4: Colours, Names and RGB/CMYK Values

		RGB						CMYK			
		red	green	blue	red	green	blue	cyan	magenta	yellow	black
	white	255	255	255	100	100	100	0	0	0	0
	black	0	0	0	0	0	0	0	0	0	100
	grey 50	127	127	127	50	50	50	0	0	0	50
	grey	190	190	190	75	75	75	0	0	0	25
	grey 90	229	229	229	90	90	90	0	0	0	10
	red	255	0	0	100	0	0	0	100	100	0
	brown	165	42	42	65	16	16	35	84	84	0
	sienna	160	82	45	63	32	18	37	68	82	0
	burlywood	222	184	135	87	72	53	13	28	47	0
	tan	210	180	140	82	71	55	18	29	45	0
	salmon	250	128	114	98	50	46	2	50	54	0
	orange red 1	255	69	0	100	27	0	0	73	100	0
	dark orange	255	140	0	100	55	0	0	45	100	0
	orange	255	165	0	100	65	0	0	35	100	0
	middle yellow	255	255	128	100	100	50	0	0	50	0
	yellow	255	255	0	100	100	0	0	0	100	0
	green-yellow	173	255	47	67	100	19	33	0	81	0
	yellow-green	154	205	50	60	80	20	40	20	80	0
	pale green 1	154	255	154	60	100	60	40	0	40	0
	light green	128	255	128	50	100	50	50	0	50	0
	green	0	255	0	0	100	0	100	0	100	0
	lawn green	124	252	0	49	99	0	51	1	100	0

		RGB						CMYK			
		red	green	blue	red	green	blue	cyan	magenta	yellow	black
	forest green	34	139	34	13	55	13	87	45	87	0
	olive drab	107	142	35	42	56	13	58	44	87	0
	turquoise	64	224	208	25	88	82	75	12	18	0
	aquamarine 1	127	255	212	50	100	83	50	0	17	0
	aquamarine 3	102	205	170	40	80	66	60	20	34	0
	aquamarine 4	69	139	116	27	55	45	73	45	55	0
	middle cyan	128	255	255	50	100	100	50	0	0	0
	cyan	0	255	255	0	100	100	100	0	0	0
	sky-blue	135	206	235	53	80	92	47	20	8	0
	deep sky-blue 1	0	191	255	0	75	100	100	25	0	0
	deep sky-blue 2	0	178	238	0	70	93	100	30	7	0
	middle blue	128	128	255	50	50	100	50	50	0	0
	royal blue	65	105	225	25	41	88	75	59	12	0
	blue	0	0	255	0	0	100	100	100	0	0
	light pink	255	182	193	100	71	76	0	29	24	0
	hot pink	255	105	180	100	41	71	0	59	29	0
	deep pink	255	20	147	100	8	58	0	92	42	0
	light magenta	255	128	255	100	50	100	0	50	0	0
	magenta	255	0	255	100	0	100	0	100	0	0
	violet	238	130	238	93	51	93	7	49	7	0
	dark violet	148	0	211	58	0	83	42	100	17	0

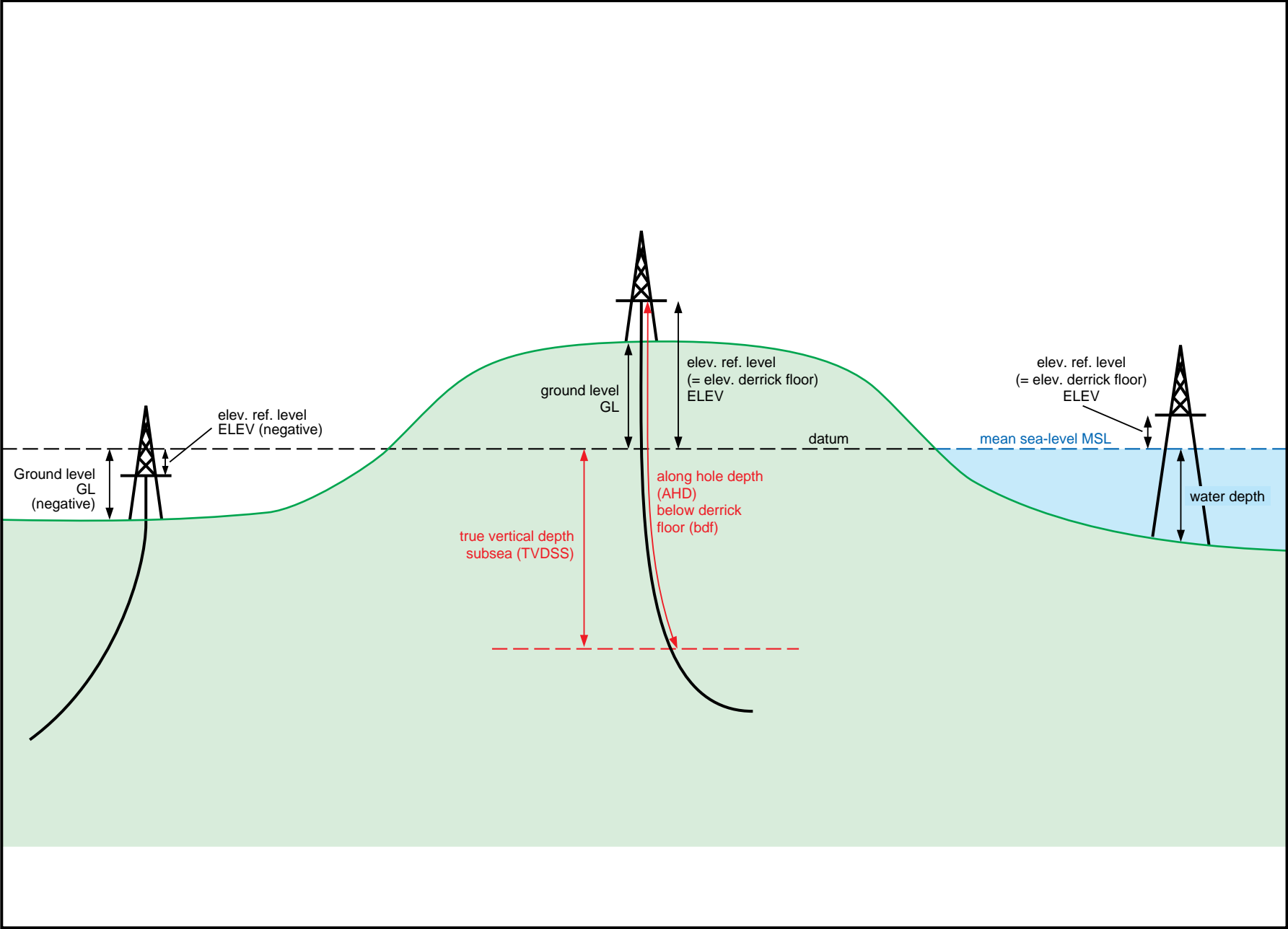

Appendix 5: Definition of Depth Measurements

Appendix 6: Thickness Definitions

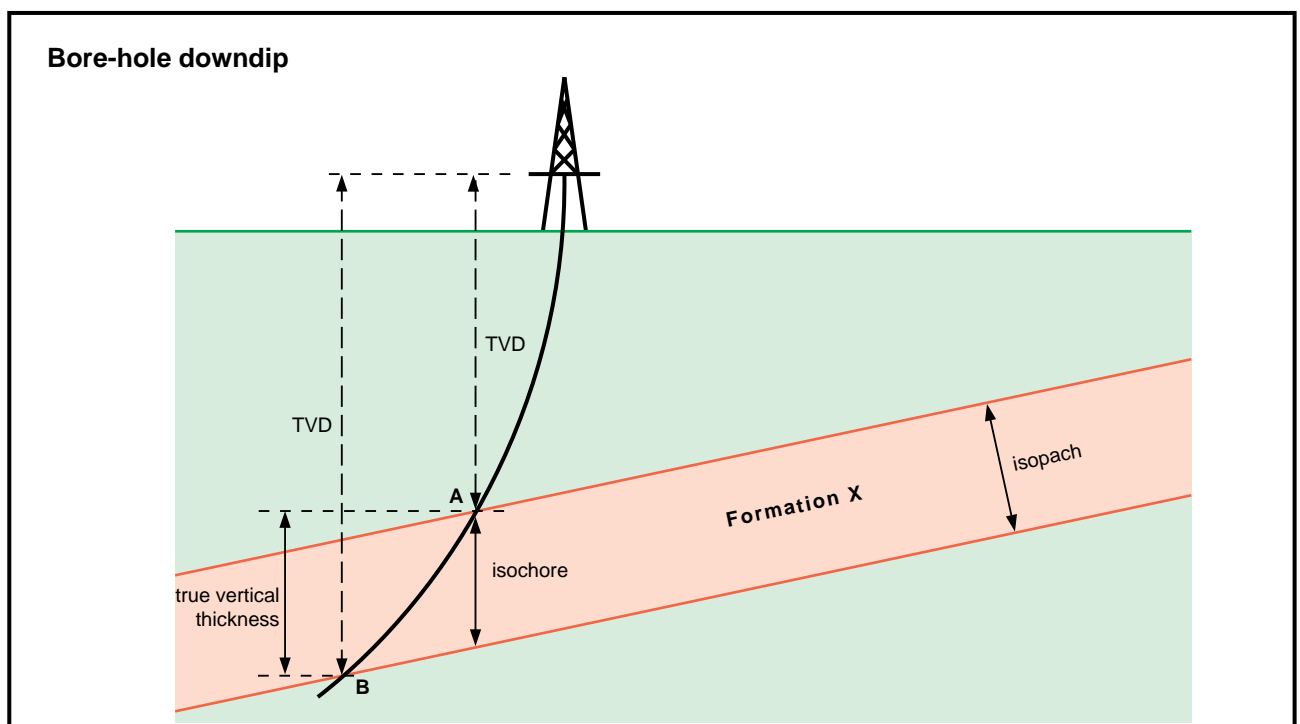
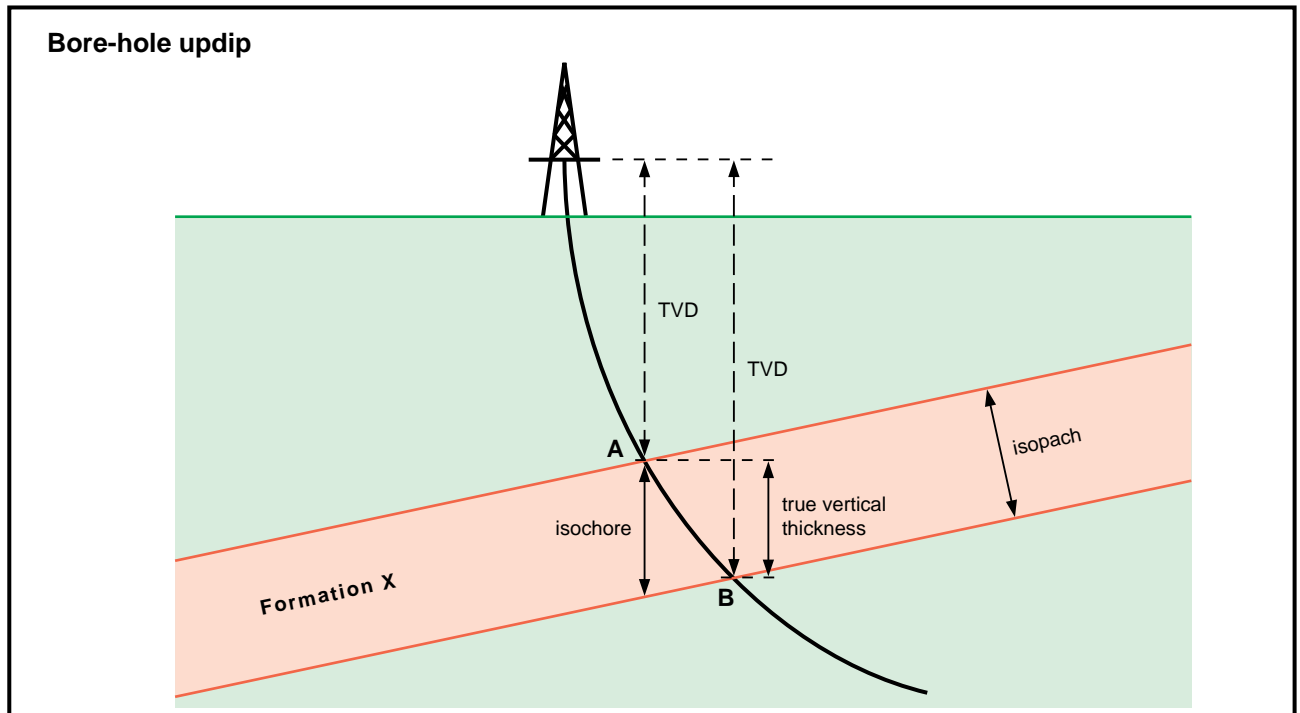

Appendix 7: The CD-ROM Version

The new Standard Legend is also available on CD-ROM in the back cover of the document. The CD-ROM offers the user extra functionality such as searching for particular words or subjects and quick navigation through the document by means of "hyperlinks" - electronic links that can be activated by simply clicking on a word or number. Note that for copyright reasons the CD-ROM does not include the fold-out figures that are available in the hard-copy.

Furthermore the CD-ROM contains graphic files of a large number of symbols from the Standard Legend.

Although use of the CD-ROM is in principle self-explanatory, this Appendix gives a brief user guide.

Installation

Before using the CD-ROM, the Adobe Acrobat Reader must be installed from the CD-ROM on your computer (DOS, Windows, Mac or UNIX machine).

DURING INSTALLATION YOU WILL BE ASKED TO ACCEPT A LICENCE AGREEMENT BETWEEN YOU AND ADOBE SYSTEMS INCORPORATED. WE ADVISE YOU TO READ THIS AGREEMENT CAREFULLY BEFORE CONTINUING INSTALLATION.

Installation instructions can be found in the README.TXT file on the CD-ROM. The Reader may be distributed licence-free and therefore can be installed on an unlimited number of computers. After installation start the Reader and click on File - Open to access the STANDLEG.PDF document.

Use of the Reader

Use of the Acrobat Reader is designed to be self-explanatory. If necessary, select Help. Note some special features of the Reader:

- Text can be copied from the Standard Legend by using Tools - Select Text and then Edit - Copy. Graphics can also be copied as a screen-dump by using Tools - Select Graphic and Edit - Copy. For applying graphics in editable format see below.
- The entire document including the Index and the Abbreviations Index can be searched for a specific word by using Tools - Find.
- Clicking on the section numbers in the indexes takes the user to the top of the particular section. In a similar way all internal document references are "hyperlinked", and by clicking on a word or number the user moves to the relevant section or appendix.

Graphics in AI and CGM

On the CD-ROM, all numbered graphics in the Standard Legend are available in two formats: AI (generic Adobe Illustrator Postscript) and CGM (Computer Graphics Metafile). Each reference number alongside a graphic refers to an .AI and a .CGM file on the CD-ROM. These files can be found in the directories \GRAPHICS\AI and \GRAPHICS\CGM. An easy way to find a graphic is to copy the reference number from the document (Tools - Select Text) and to paste this in e.g. the File - Search option in the File Manager (Windows only).

All graphics may be copied to a local system and reused in any application that handles these formats.

For draughting applications it is preferable to import the AI format. The editable Postscript format AI is much more 'intelligent' than the editable but rudimentary CGM format. Applications capable of importing the AI format include CorelDraw, Freelance, Designer, Canvas, Freehand. Some of the numbered graphics are designed as 'tiles' which can be used as building blocks to fill defined areas with lithological symbols (patterns).

Note that the CGM files can only be scaled up to 1000 % without noticeable loss of quality.